

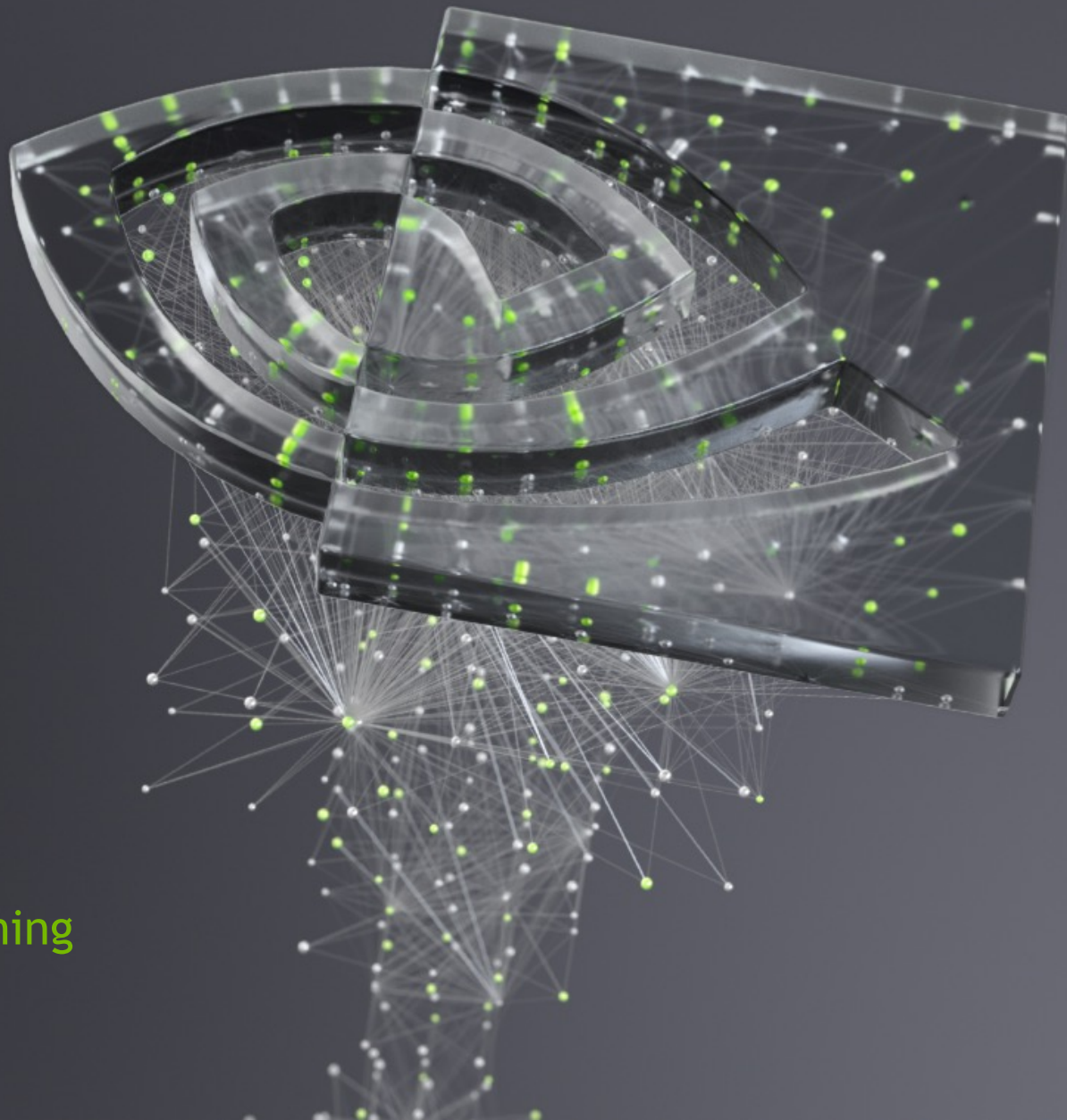

DEEP
LEARNING
INSTITUTE

FUNDAMENTALS OF DEEP LEARNING

Part 1: An Introduction to Deep Learning



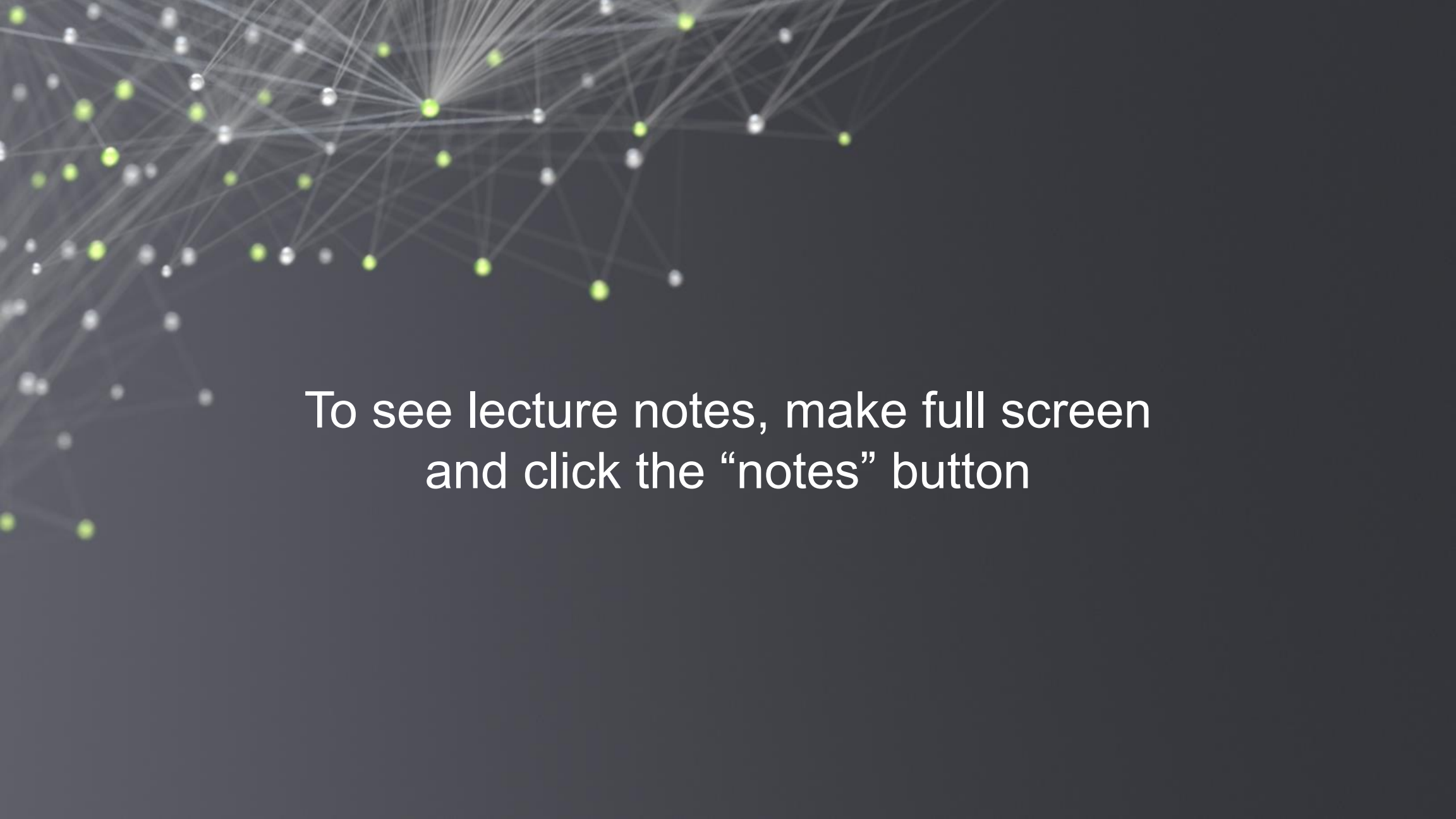

To see lecture notes, make full screen
and click the “notes” button



WELCOME!

THE GOALS OF THIS COURSE

- Get you up and on your feet quickly
- Build a foundation to tackle a deep learning project right away
- We won't cover the whole field, but we'll get a great head start
- Foundation from which to read articles, follow tutorials, take further classes

AGENDA

Part 1: An Introduction to Deep Learning

Part 2: How a Neural Network Trains

Part 3: Convolutional Neural Networks

Part 4: Data Augmentation and Deployment

Part 5: Pre-trained Models

Part 6: Advanced Architectures

AGENDA – PART I

- History of AI
- The Deep Learning Revolution
- What is Deep Learning
- How Deep Learning is Transforming the World
- Overview of the Course
- First Exercise

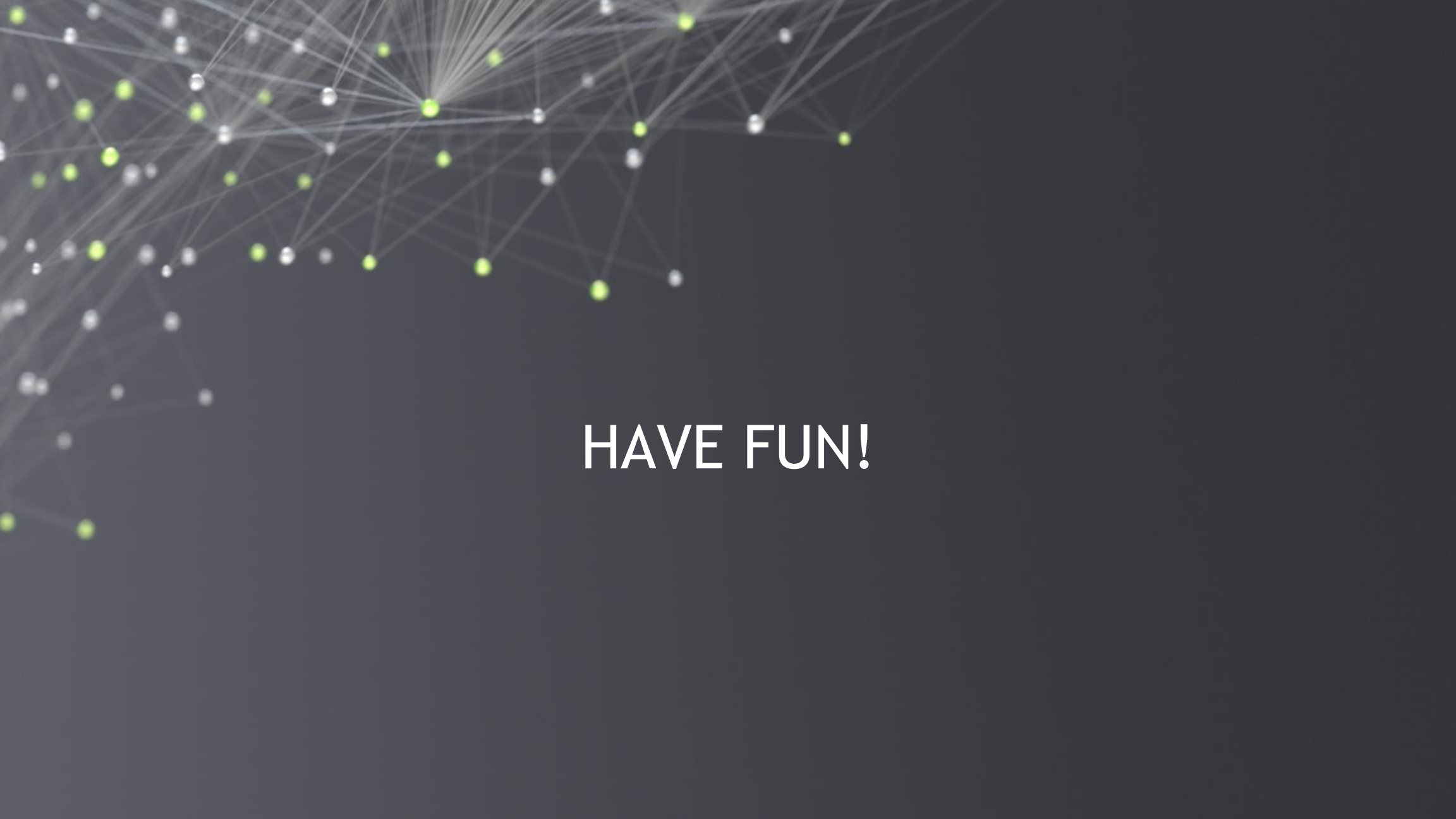

HAVE FUN!

HUMAN VS MACHINE LEARNING

Relaxed Alertness

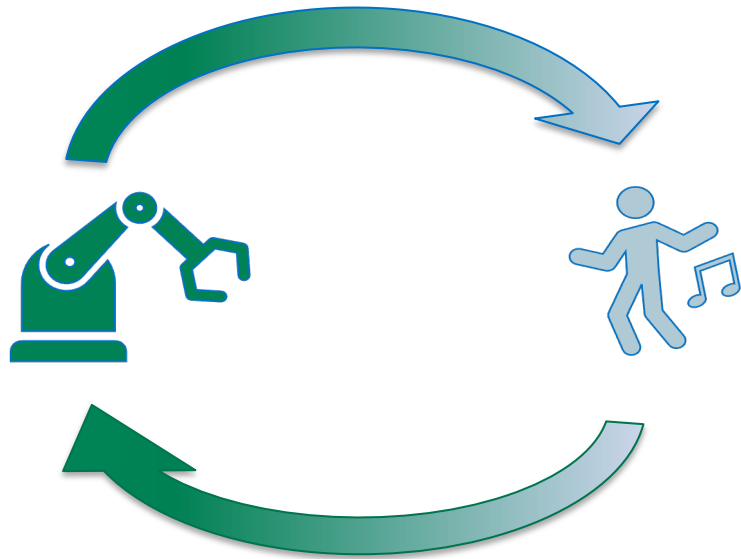

Human	Machine
Rest and Digest	Training
Fight-or-flight	Prediction



LET'S GET STARTED



HISTORY OF AI

BEGINNING OF ARTIFICIAL INTELLIGENCE



COMPUTERS ARE MADE IN
PART TO COMPLETE HUMAN
TASKS



EARLY ON, GENERALIZED
INTELLIGENCE LOOKED
POSSIBLE



TURNED OUT TO BE HARDER
THAN EXPECTED

EARLY NEURAL NETWORKS

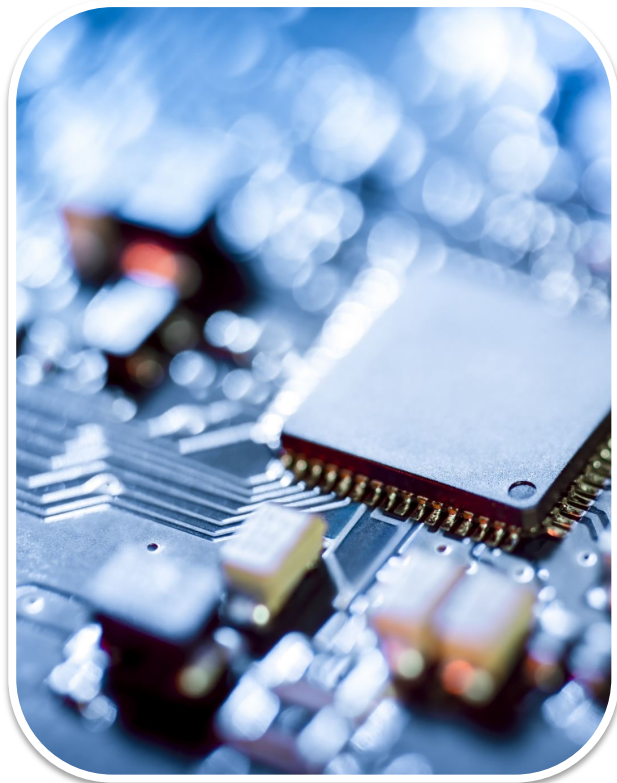

Inspired by biology

Created in the 1950's

Outclassed by Von Neumann Architecture

EXPERT SYSTEMS



Highly complex



Programmed by hundreds of engineers



Rigorous programming of many rules

EXPERT SYSTEMS - LIMITATIONS

What are these three images?



HOW DO CHILDREN LEARN?



- Expose them to lots of data
- Give them the “correct answer”
- They will pick up the important patterns on their own



THE DEEP LEARNING REVOLUTION

DATA

- Networks need a lot of information to learn from
- The digital era and the internet has supplied that data



COMPUTING POWER

Need a way for our artificial “brain” to observe lots of data within a practical amount of time.



THE IMPORTANCE OF THE GPU

A Rendered Image



A Neural Network

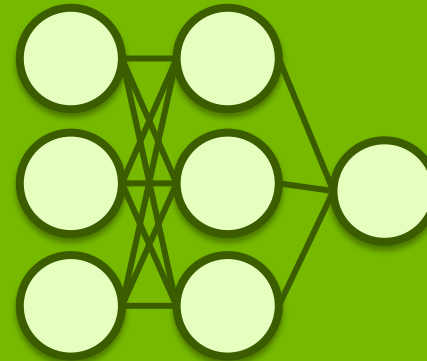



WHAT IS DEEP LEARNING?



DEEP LEARNING FLIPS TRADITIONAL PROGRAMMING ON ITS HEAD

TRADITIONAL PROGRAMMING

Building a Classifier

1

Define a set of
rules for
classification

2

Program those
rules into the
computer

3

Feed it examples,
and the program
uses the rules to
classify

MACHINE LEARNING

Building a Classifier

1

Show model the examples with the answer of how to classify

2

Model takes guesses, we tell it if it's right or not

3

Model learns to correctly categorize as it's training. The system learns the rules on its own



THIS IS A FUNDAMENTAL SHIFT

WHEN TO CHOOSE DEEP LEARNING

Classic Programming

If rules are clear
and
straightforward,
often better to just
program it

Deep Learning

If rules are
nuanced, complex,
difficult to discern,
use deep learning

DEEP LEARNING COMPARED TO OTHER AI

Depth and complexity of networks

Up to billions of parameters (and growing)

Many layers in a model

Important for learning complex rules



HOW DEEP LEARNING IS
TRANSFORMING THE WORLD

COMPUTER VISION

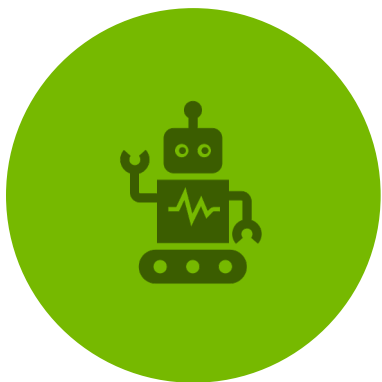

**ROBOTICS AND
MANUFACTURING**



**OBJECT
DETECTION**



**SELF DRIVING
CARS**

NATURAL LANGUAGE PROCESSING



REAL TIME
TRANSLATION



VOICE
RECOGNITION



VIRTUAL
ASSISTANTS

RECOMMENDER SYSTEMS



CONTENT
CURATION



TARGETED
ADVERTISING



SHOPPING
RECOMMENDATIONS

REINFORCEMENT LEARNING



ALPHAGO BEATS
WORLD CHAMPION
IN GO



AI BOTS BEAT
PROFESSIONAL
VIDEOGAMERS



STOCK TRADING
ROBOTS



OVERVIEW OF THE COURSE

HANDS ON EXERCISES

- Get comfortable with the process of deep learning
- Exposure to different models and datatypes
- Get a jump-start to tackle your own projects



STRUCTURE OF THE COURSE

“Hello World” of Deep Learning



```
graph TD; A["“Hello World” of Deep Learning"] --> B["Train a more complicated model"]; B --> C["New architectures and techniques to improve performance"]; C --> D["Pre-trained models"]; D --> E["Transfer learning"];
```

Train a more complicated model

New architectures and techniques to improve performance

Pre-trained models

Transfer learning

PLATFORM OF THE COURSE



GPU powered cloud server



JupyterLab platform



Jupyter notebooks for interactive coding

SOFTWARE OF THE COURSE

- Major deep learning platforms:
 - TensorFlow + Keras (Google)
 - Pytorch (Facebook)
 - MXNet (Apache)
- We'll be using TensorFlow and Keras
- Good idea to gain exposure to others moving forward

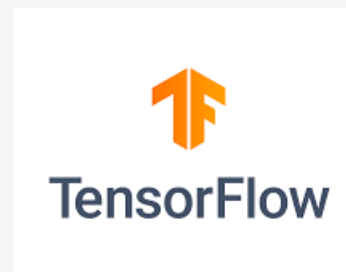



**FIRST EXERCISE:
CLASSIFY HANDWRITTEN
DIGITS**

HELLO NEURAL NETWORKS

Train a network to correctly classify handwritten digits

- Historically important and difficult task for computers

Try learning like a Neural Network

- Get exposed to the example, and try to figure out the rules to how it works



LET'S GO!

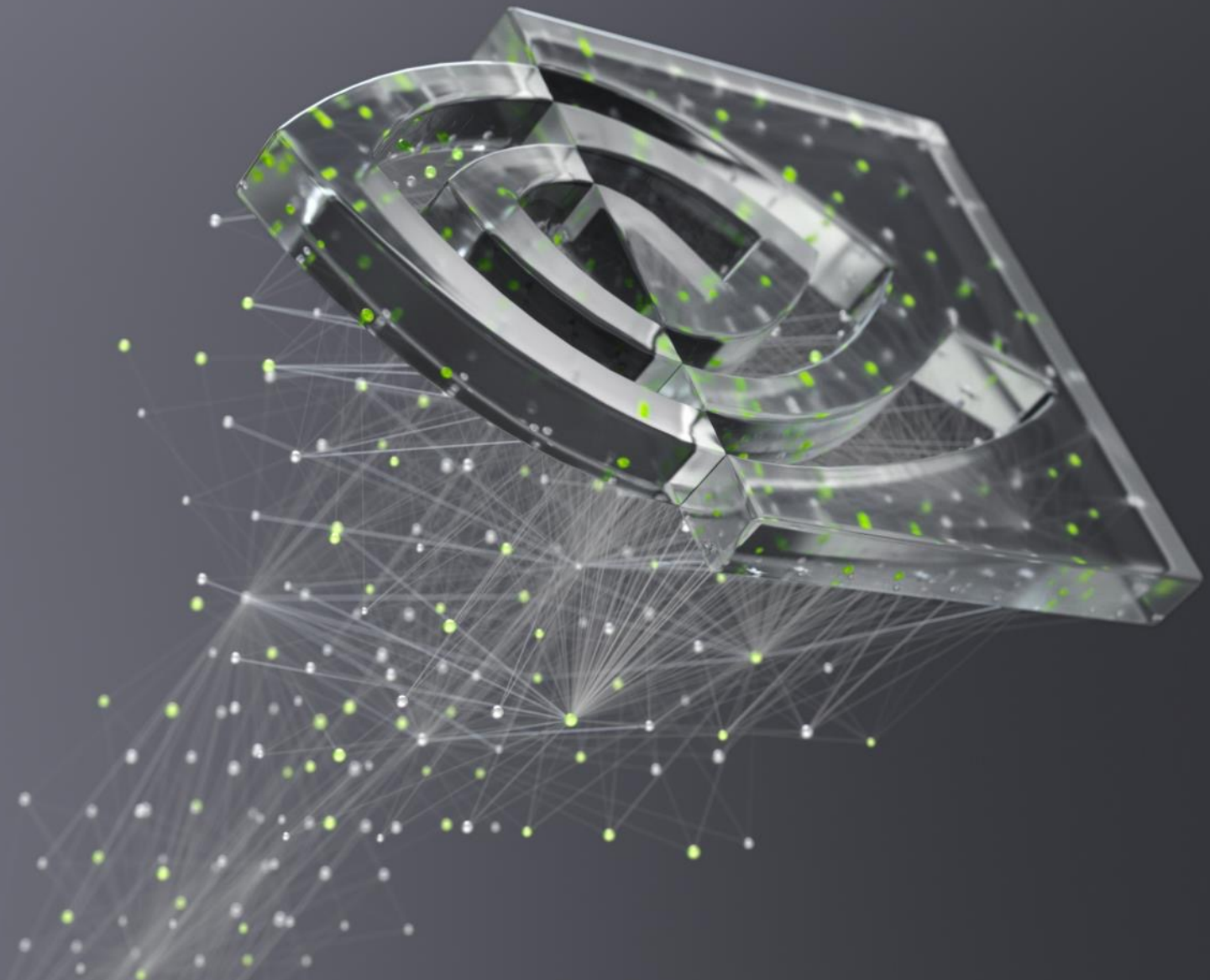

DEEP
LEARNING
INSTITUTE



DEEP
LEARNING
INSTITUTE

FUNDAMENTALS OF DEEP LEARNING

Part 2: How a Neural Network Trains

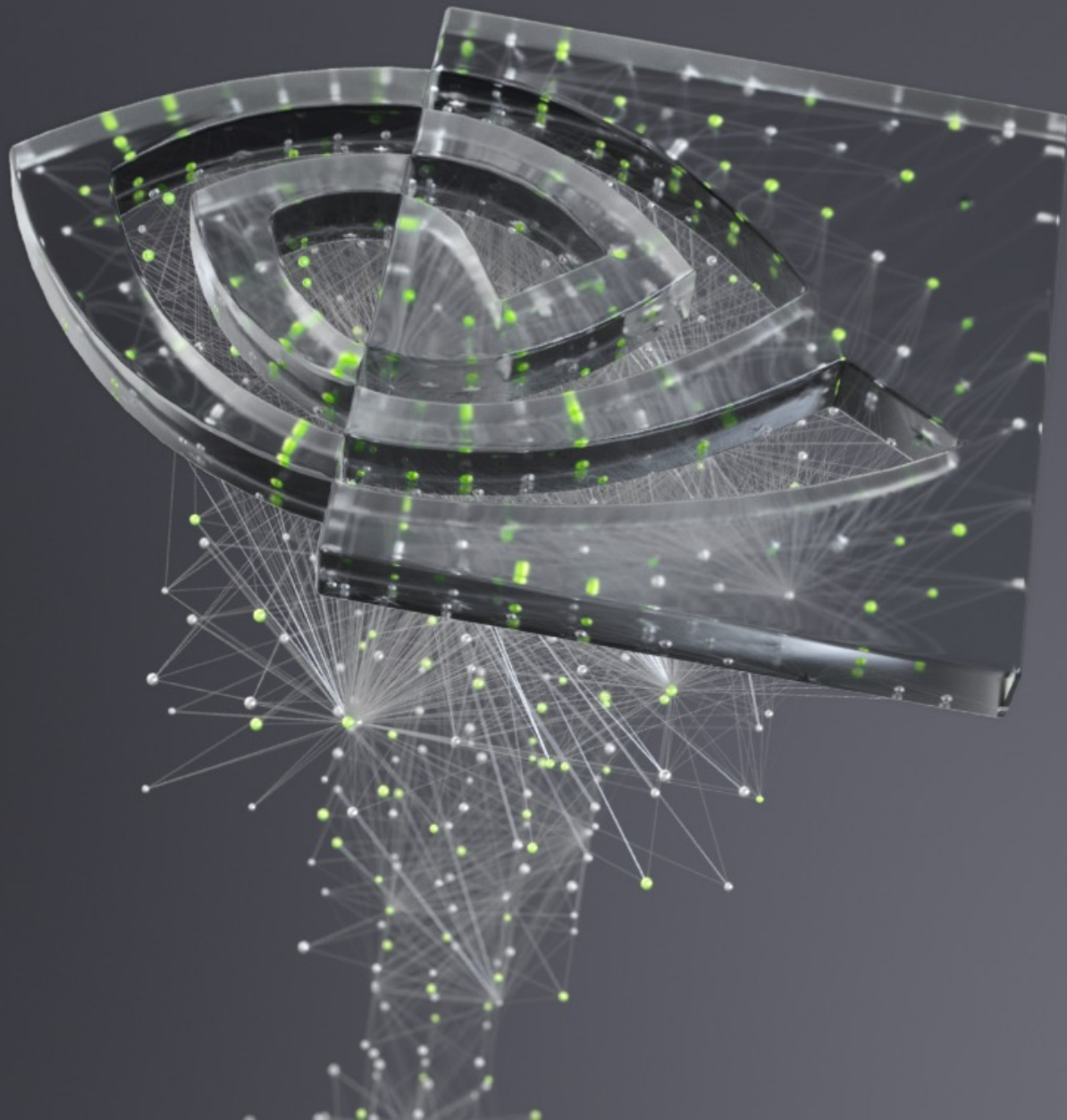

Part 1: An Introduction to Deep Learning

Part 2: How a Neural Network Trains

Part 3: Convolutional Neural Networks

Part 4: Data Augmentation and Deployment

Part 5: Pre-trained Models

Part 6: Advanced Architectures

-
-
-
-
-
-

RECAP OF THE EXERCISE

What just happened?

Loaded and visualized our data



Edited our data (reshaped, normalized, to categorical)



Created our model



Compiled our model



Trained the model on our data

DATA PREPARATION

Input as an array

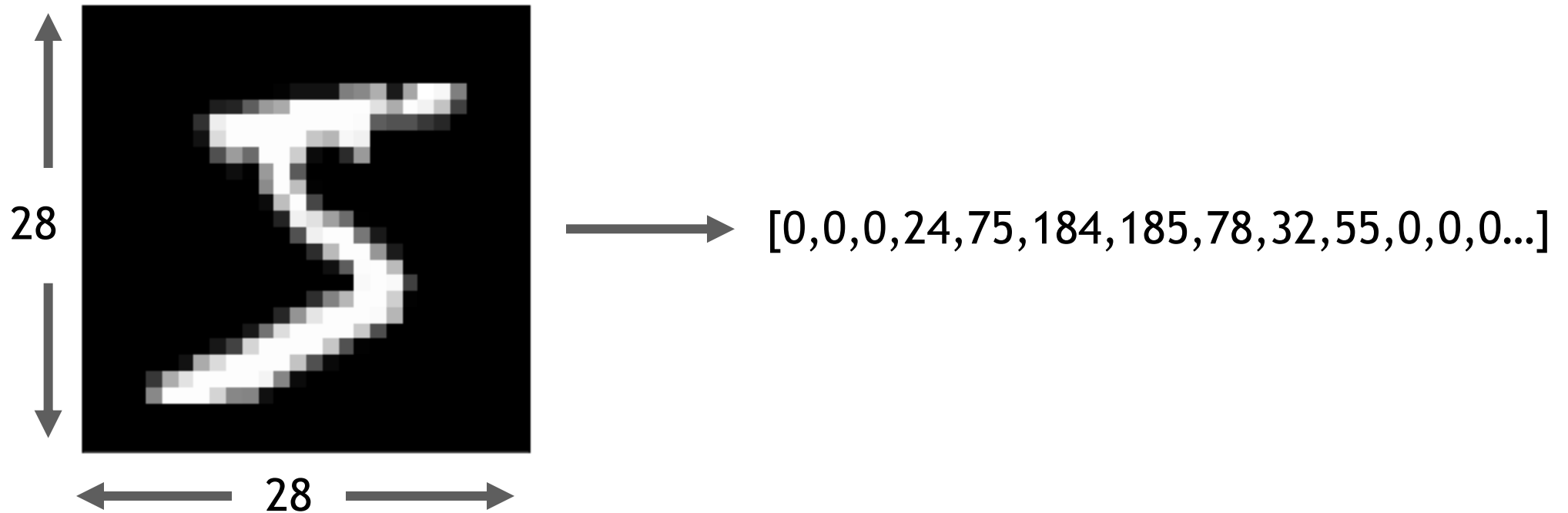

DATA PREPARATION

Targets as categories

0 → [1,0,0,0,0,0,0,0,0,0]

1 → [0,1,0,0,0,0,0,0,0,0]

2 → [0,0,1,0,0,0,0,0,0,0]

3 → [0,0,0,1,0,0,0,0,0,0]

•
•
•

AN UNTRAINED MODEL

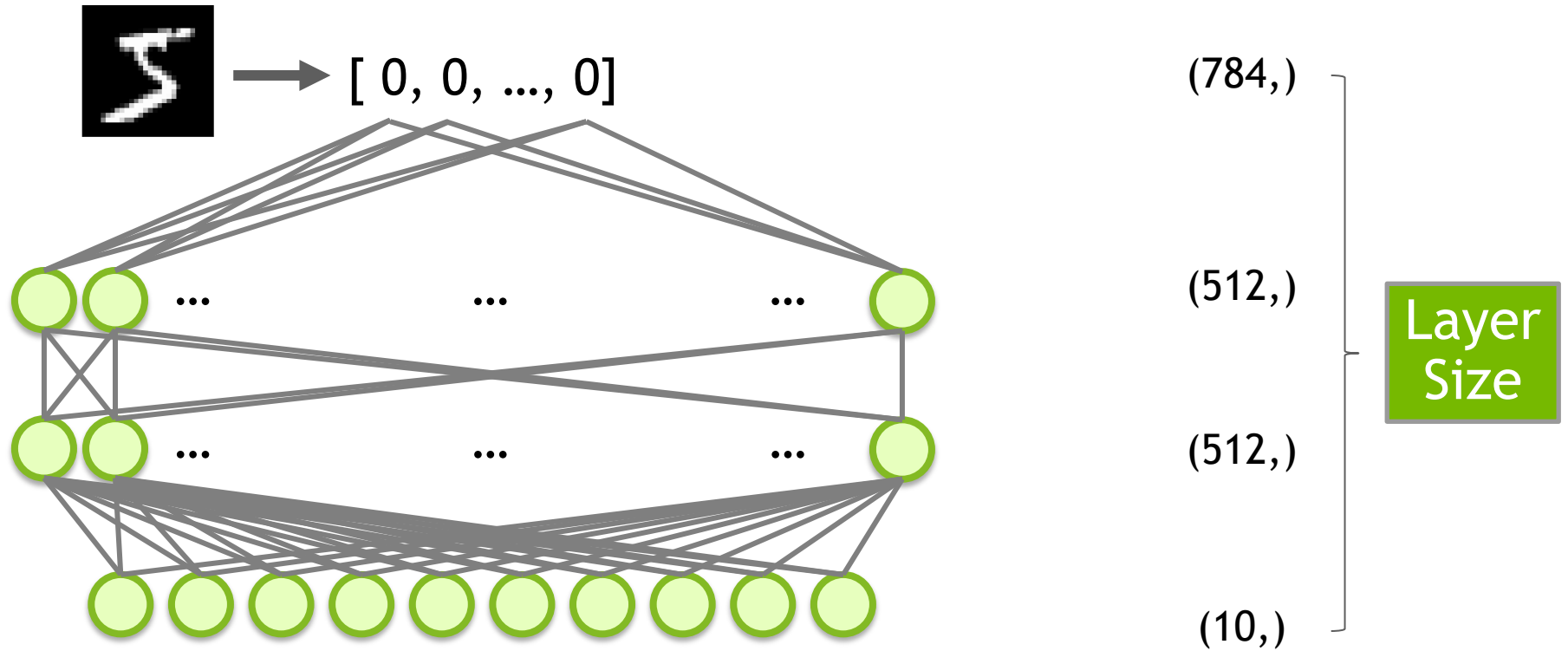



A SIMPLER MODEL

A SIMPLER MODEL

$$y = mx + b$$

x	y
1	3
2	5

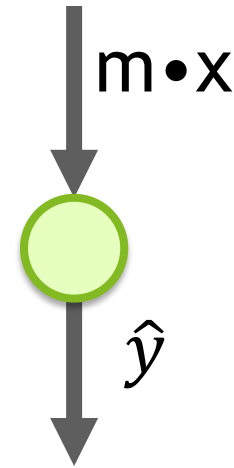
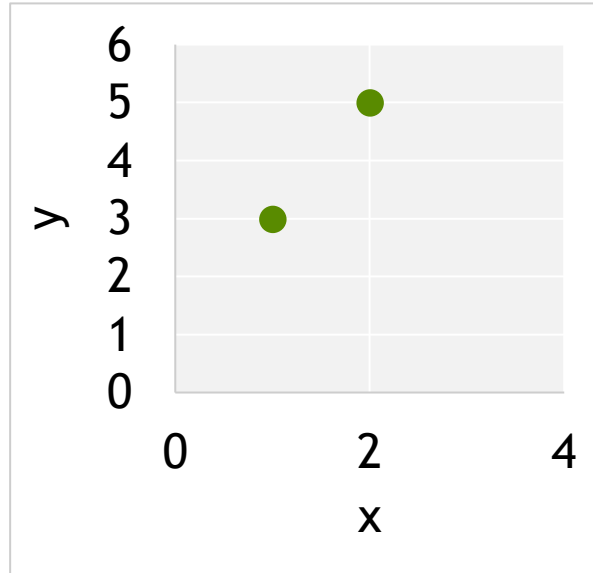

$m = ?$

$b = ?$

A SIMPLER MODEL

$$y = mx + b$$

x	y
1	3
2	5

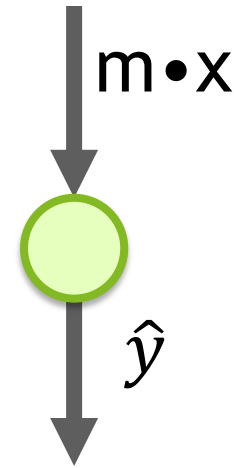
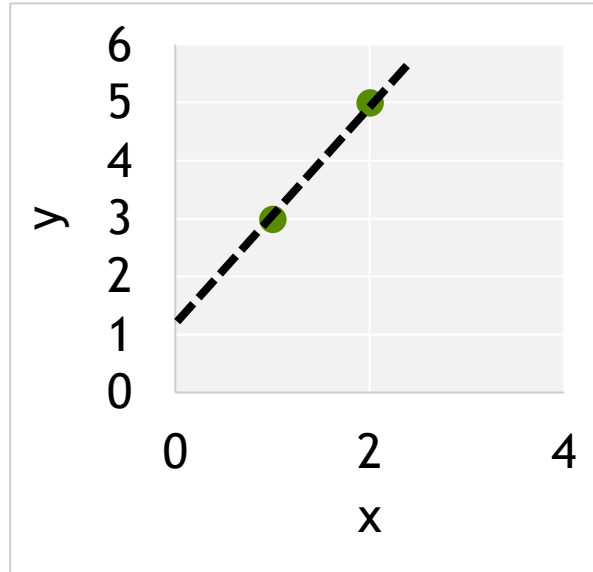

$$m = ?$$

$$b = ?$$

A SIMPLER MODEL

$$y = mx + b$$

x	y	\hat{y}
1	3	4
2	5	3

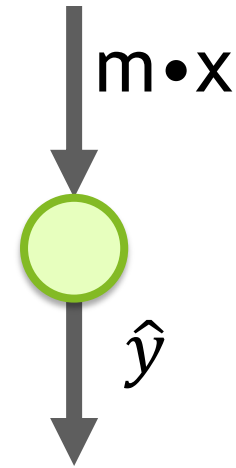
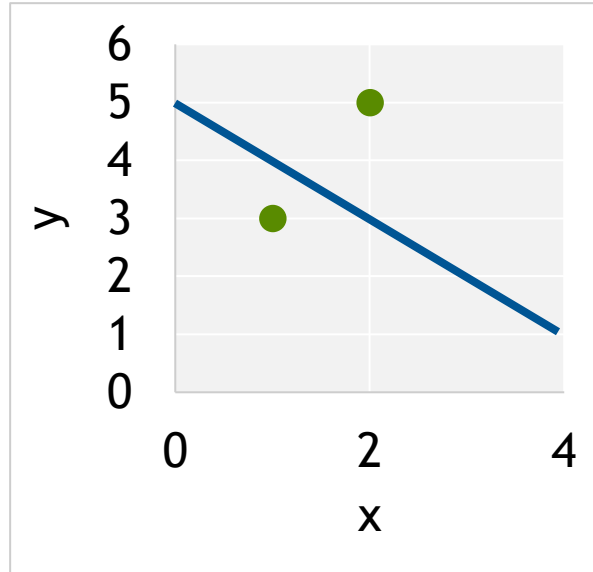

Start
Random

$$m = -1$$

$$b = 5$$

A SIMPLER MODEL

$$y = mx + b$$

x	y	\hat{y}	err^2
1	3	4	1
2	5	3	4
MSE =			2.5
RMSE =			1.6

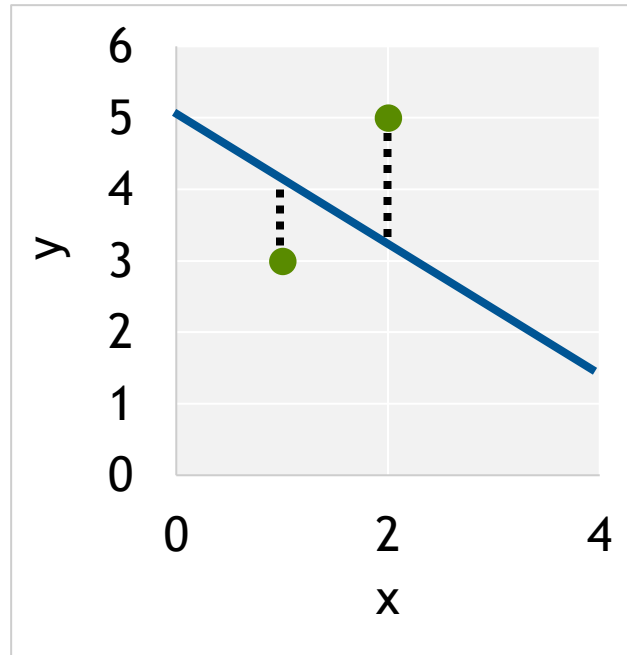

$$MSE = \frac{1}{n} \sum_{i=1}^n (y_i - \hat{y}_i)^2$$

$$RMSE = \sqrt{\frac{1}{n} \sum_{i=1}^n (y_i - \hat{y}_i)^2}$$

A SIMPLER MODEL

$$y = mx + b$$

x	y	\hat{y}	err^2
1	3	4	1
2	5	3	4
MSE =			2.5
RMSE =			1.6

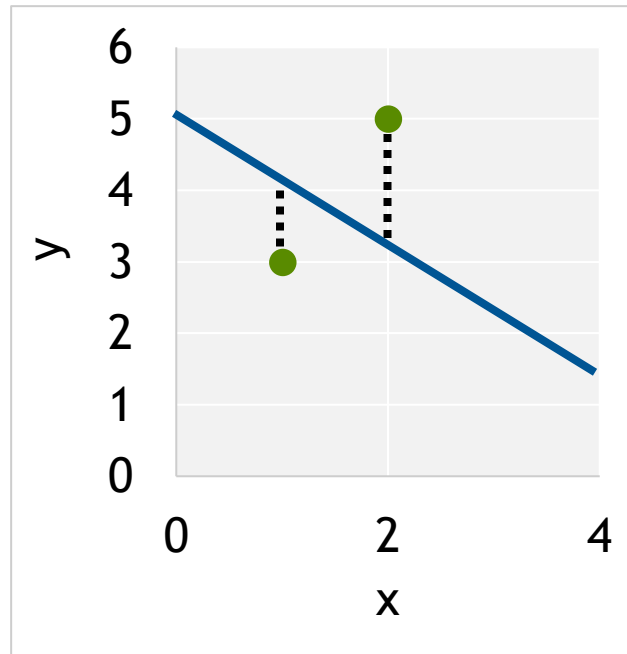

```
1 data = [(1, 3), (2, 5)]
2 m = -1
3 b = 5
4
5
6 def get_rmse(data, m, b):
7     """Calculates Mean Square Error"""
8     n = len(data)
9     squared_error = 0
10    for x, y in data:
11        # Find predicted y
12        y_hat = m*x+b
13        # Square difference between
14        # prediction and true value
15        squared_error += (
16            y - y_hat)**2
17        # Get average squared difference
18        mse = squared_error / n
19        # Square root for original units
20        return mse ** .5
21
```

THE LOSS CURVE

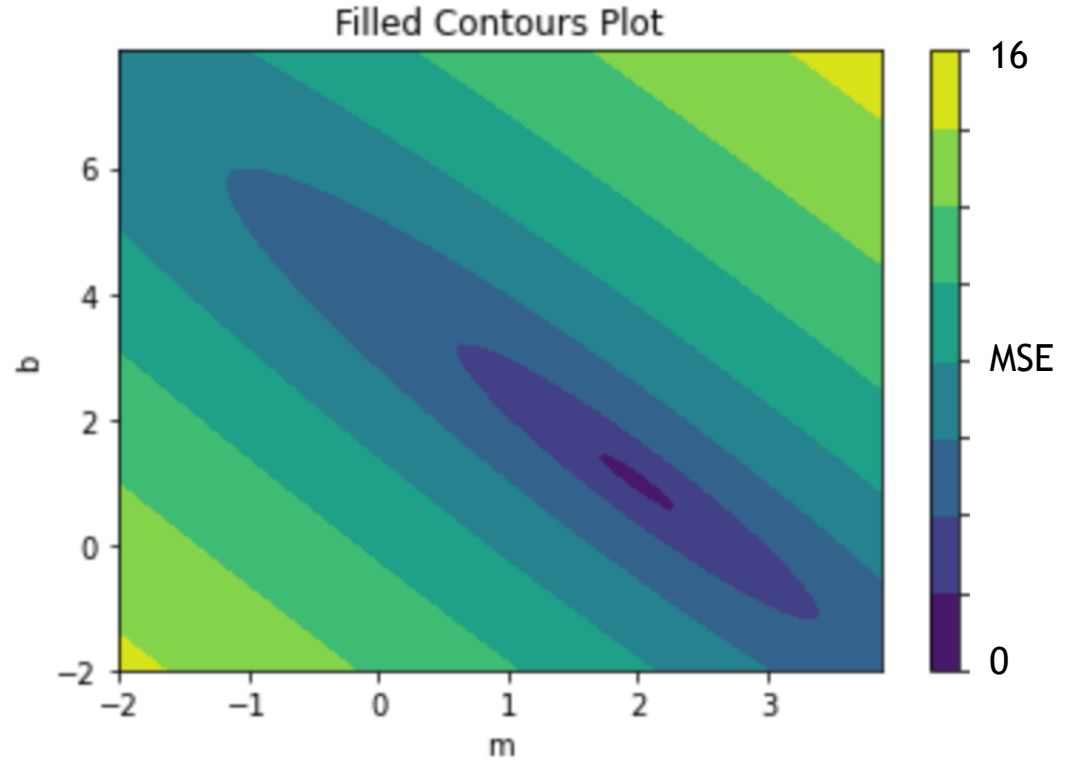
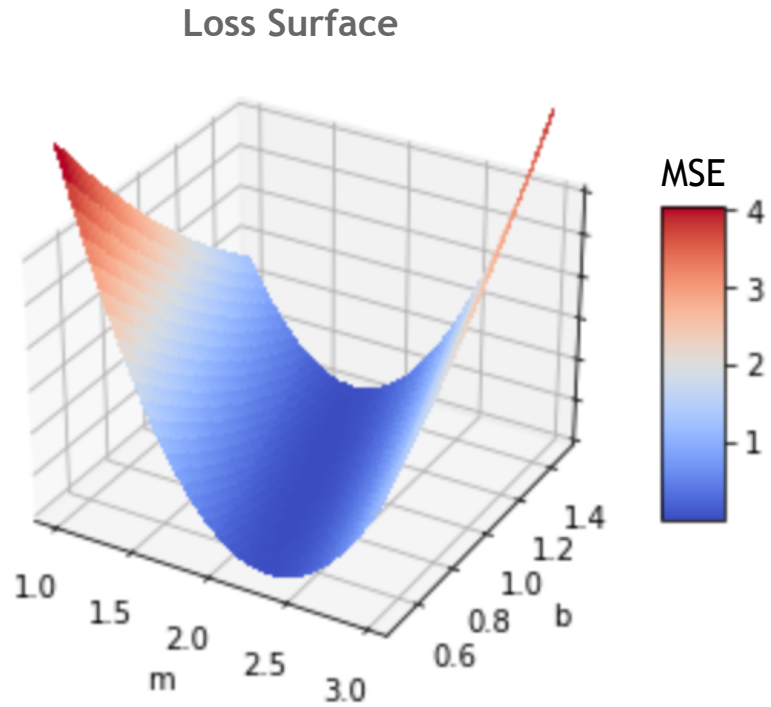

THE LOSS CURVE

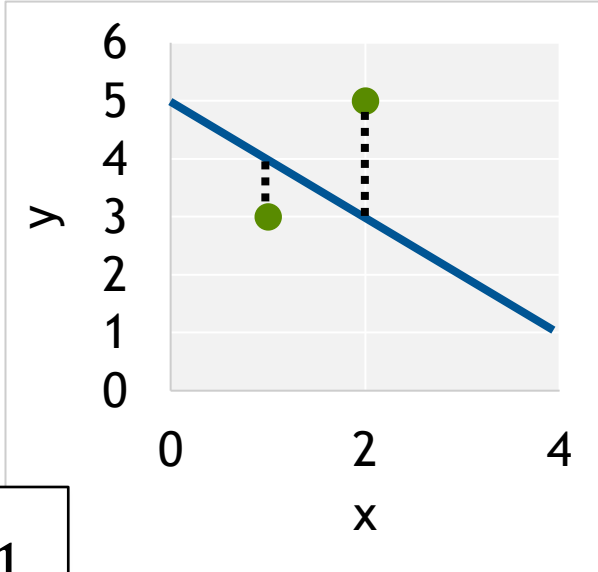

$m = -1$
 $b = 5$

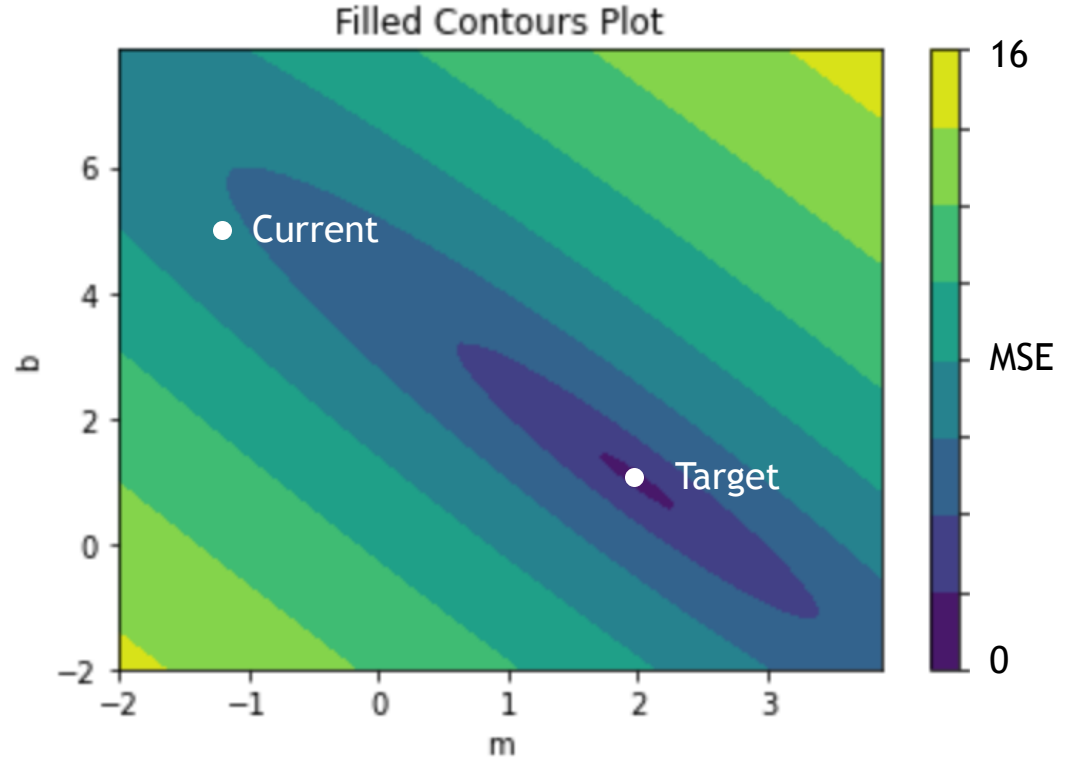

THE LOSS CURVE

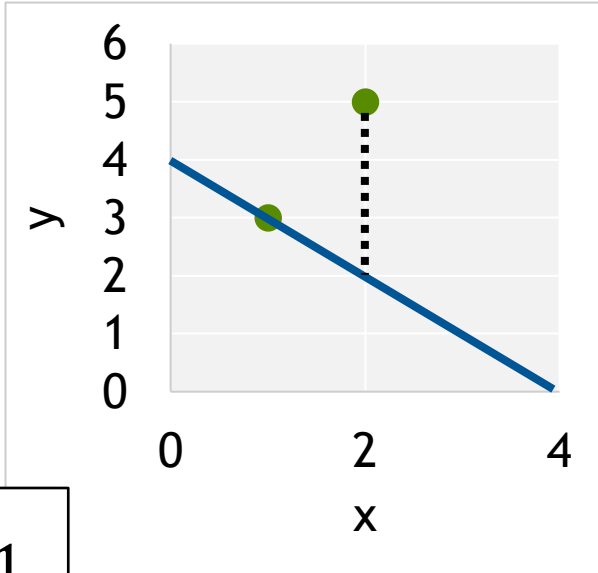

$m = -1$
 $b = 4$

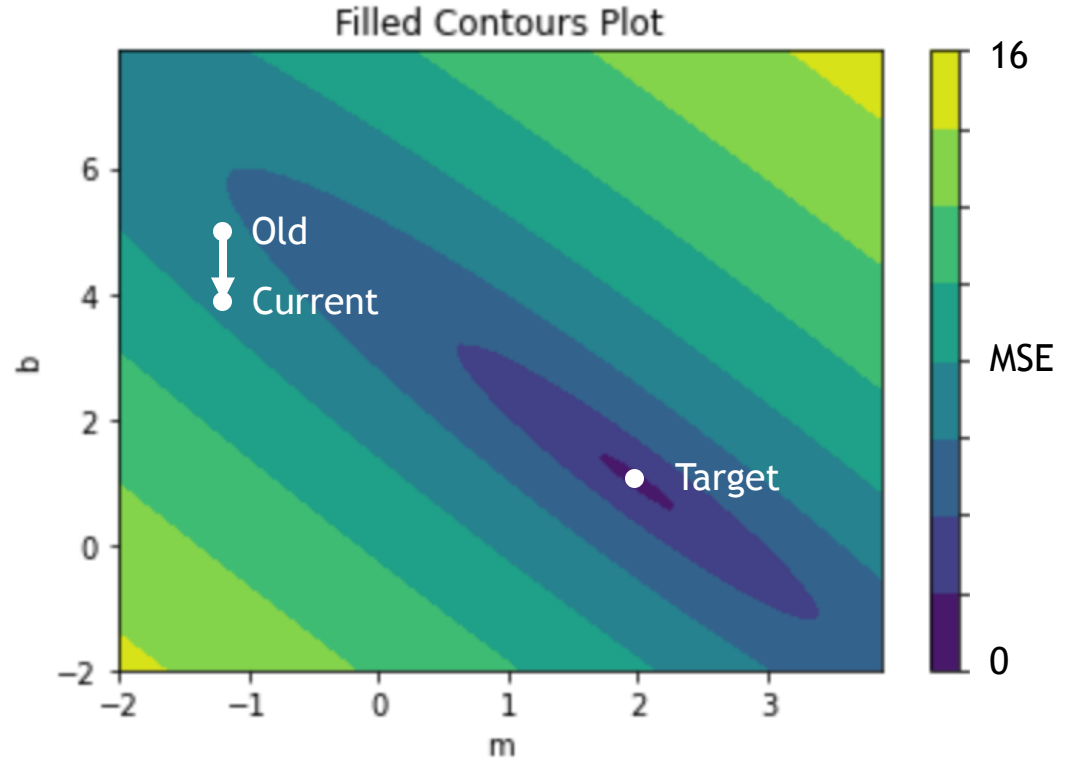

THE LOSS CURVE

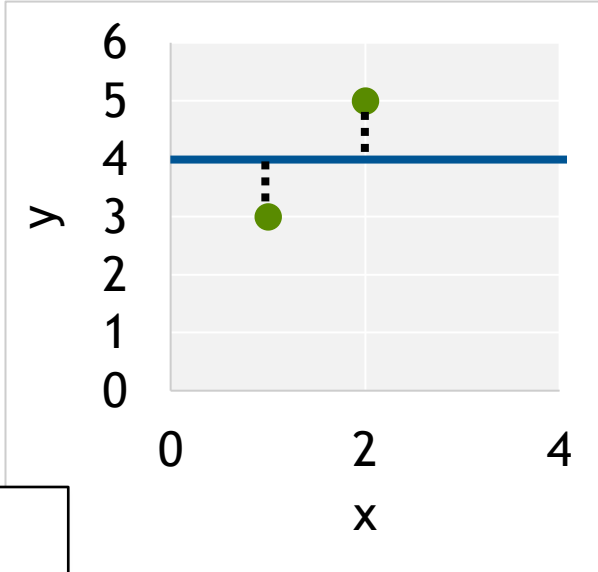

$m = 0$
 $b = 4$

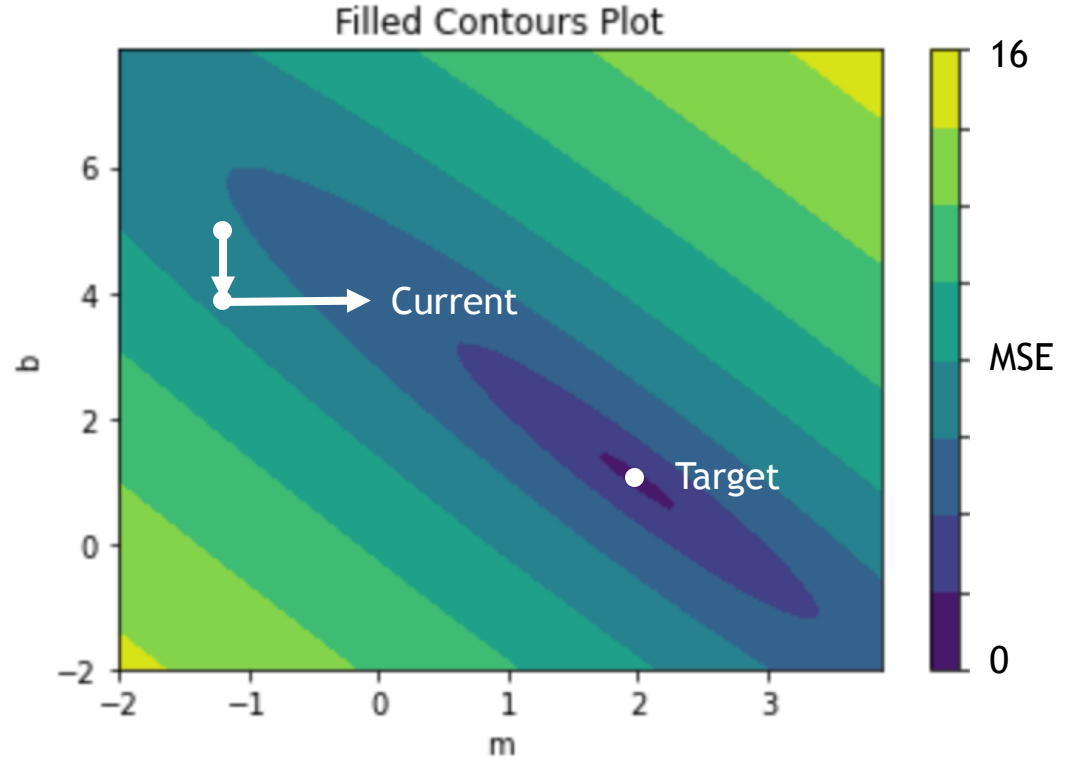

THE LOSS CURVE

The Gradient	Which direction loss decreases the most
λ : The learning rate	How far to travel
Epoch	A model update with the full dataset
Batch	A sample of the full dataset
Step	An update to the weight parameters

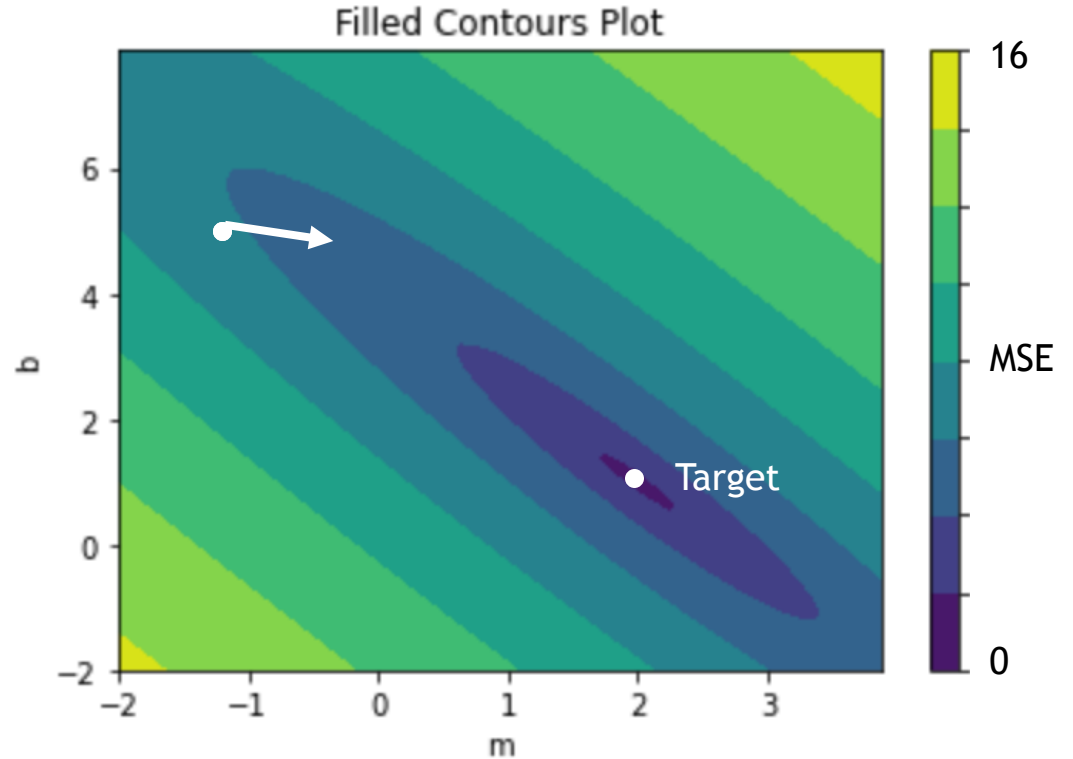

THE LOSS CURVE

The Gradient	Which direction loss decreases the most
λ : The learning rate	How far to travel
Epoch	A model update with the full dataset
Batch	A sample of the full dataset
Step	An update to the weight parameters



OPTIMIZERS

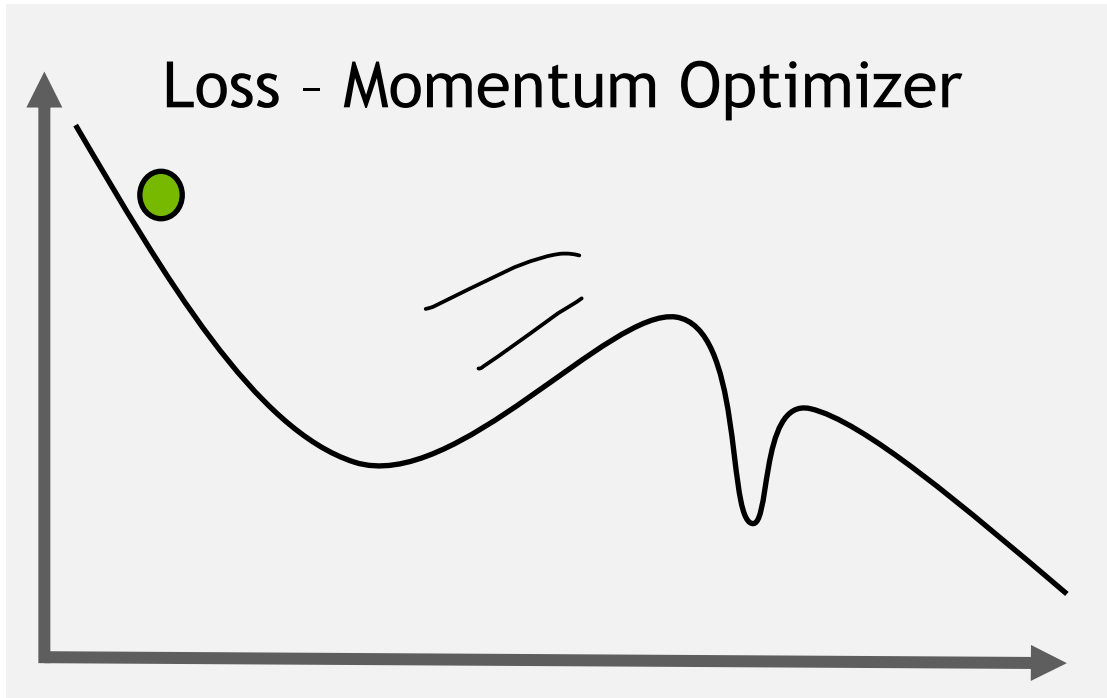

- Adam
- Adagrad
- RMSprop
- SGD



FROM NEURON TO NETWORK

BUILDING A NETWORK

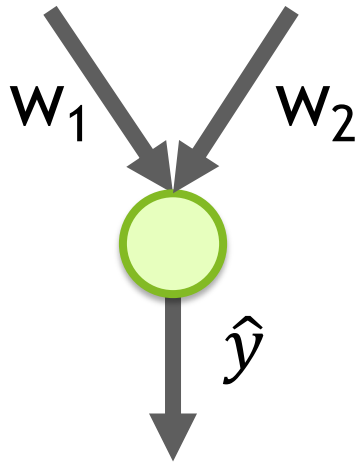

- Scales to more inputs

BUILDING A NETWORK

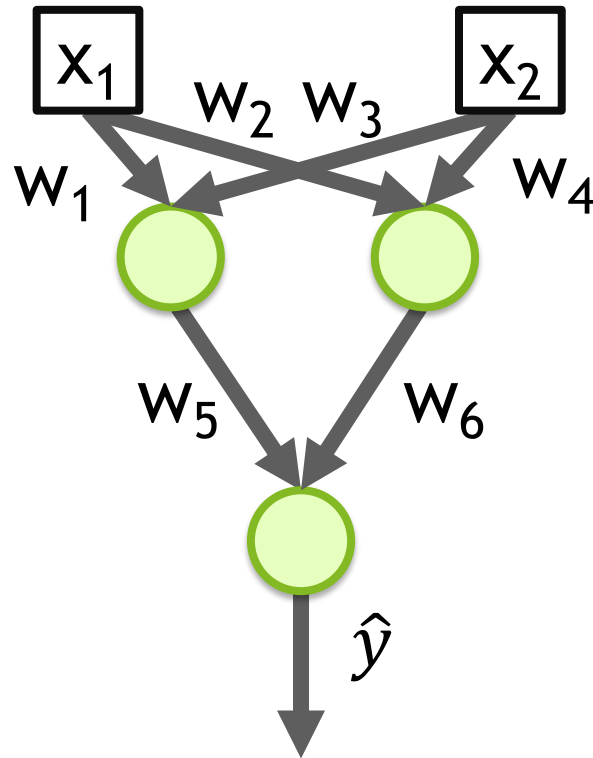

- Scales to more inputs
- Can chain neurons

BUILDING A NETWORK

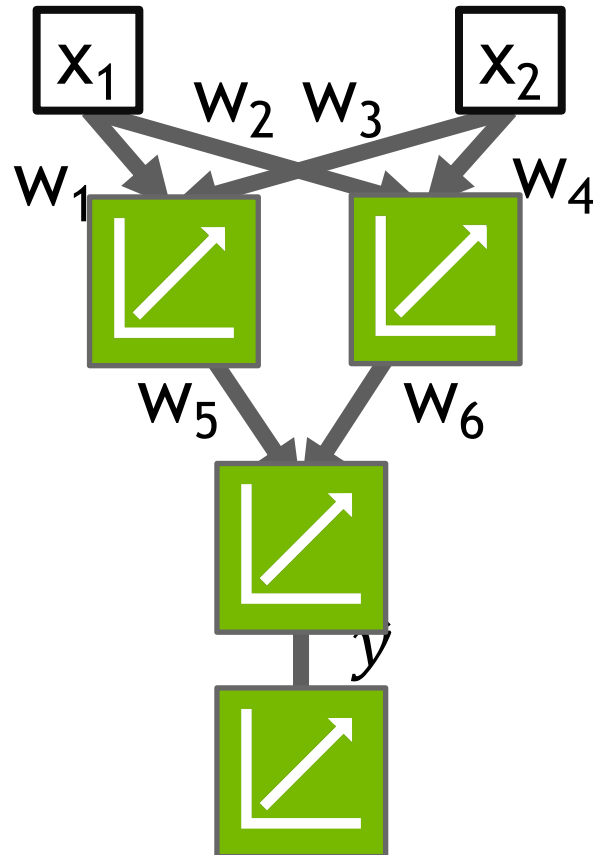

- Scales to more inputs
- Can chain neurons
- If all regressions are linear, then output will also be a linear regression



ACTIVATION FUNCTIONS

ACTIVATION FUNCTIONS

Linear

$$\hat{y} = wx + b$$

```
1 # Multiply each input
2 # with a weight (w) and
3 # add intercept (b)
4 y_hat = wx+b
```

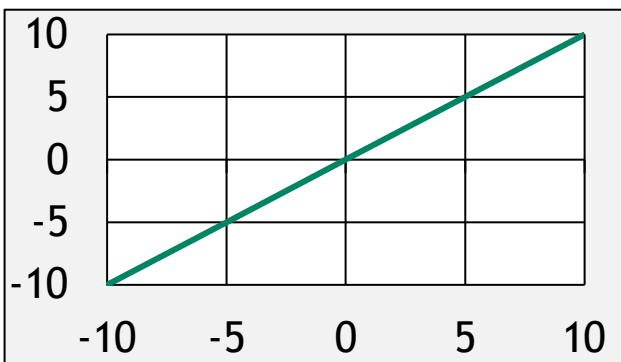

ReLU

$$\hat{y} = \begin{cases} wx + b & \text{if } wx + b > 0 \\ 0 & \text{otherwise} \end{cases}$$

```
1 # Only return result
2 # if total is positive
3 linear = wx+b
4 y_hat = linear * (linear > 0)
```

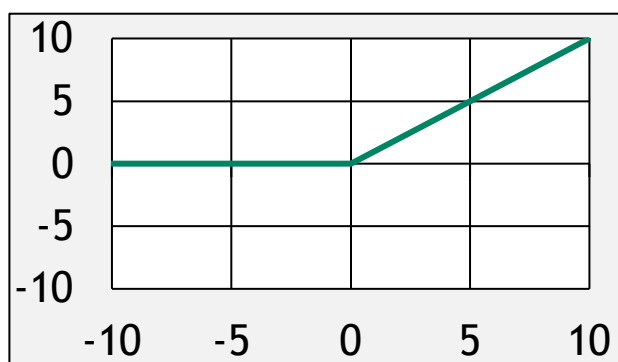

Sigmoid

$$\hat{y} = \frac{1}{1 + e^{-(wx+b)}}$$

```
1 # Start with line
2 linear = wx + b
3 # Warp to - inf to 0
4 inf_to_zero = np.exp(-1 * linear)
5 # Squish to -1 to 1
6 y_hat = 1 / (1 + inf_to_zero)
```

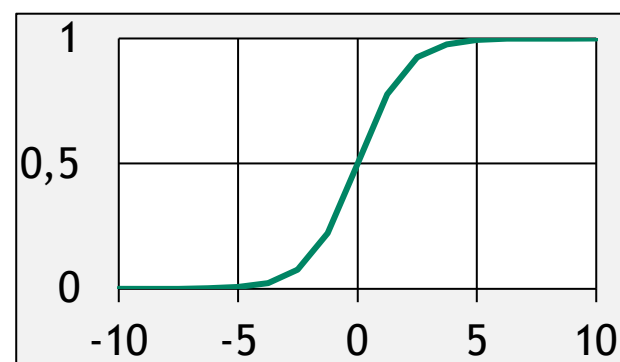

ACTIVATION FUNCTIONS

Linear

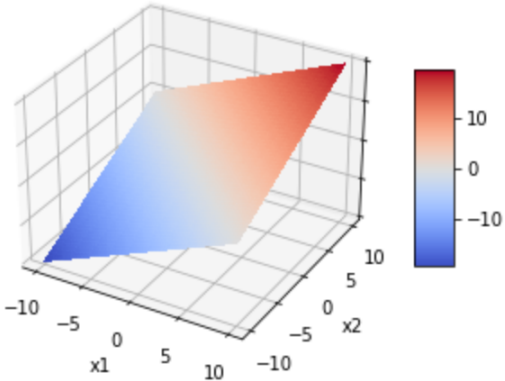

ReLU

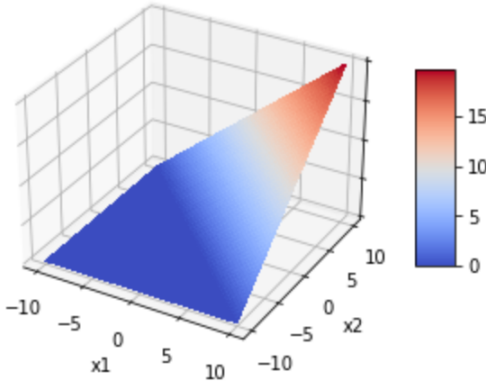

Sigmoid

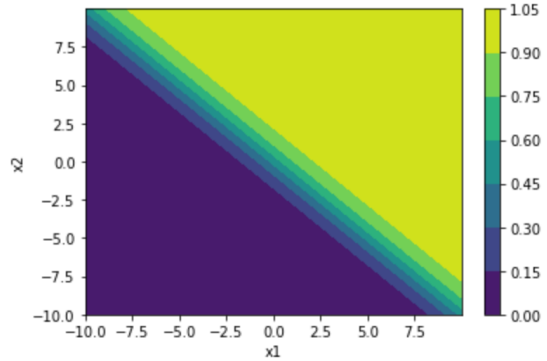
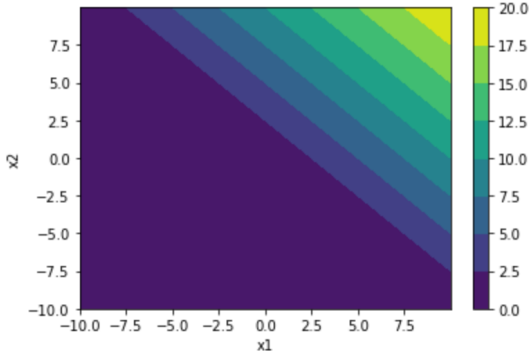
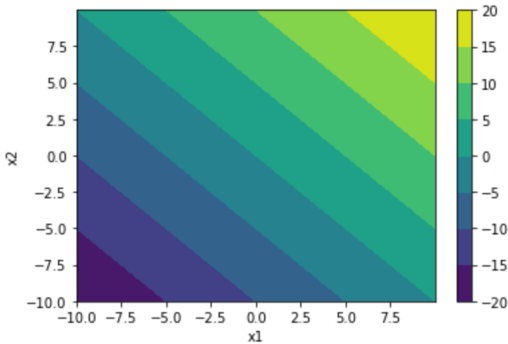
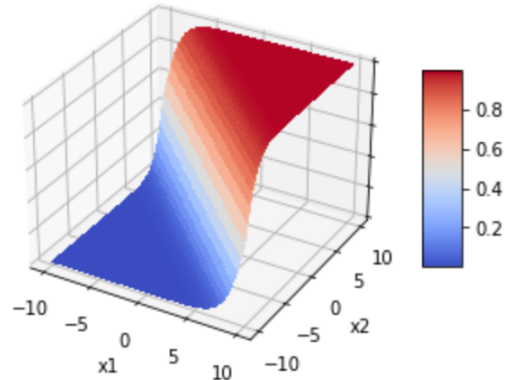

ACTIVATION FUNCTIONS

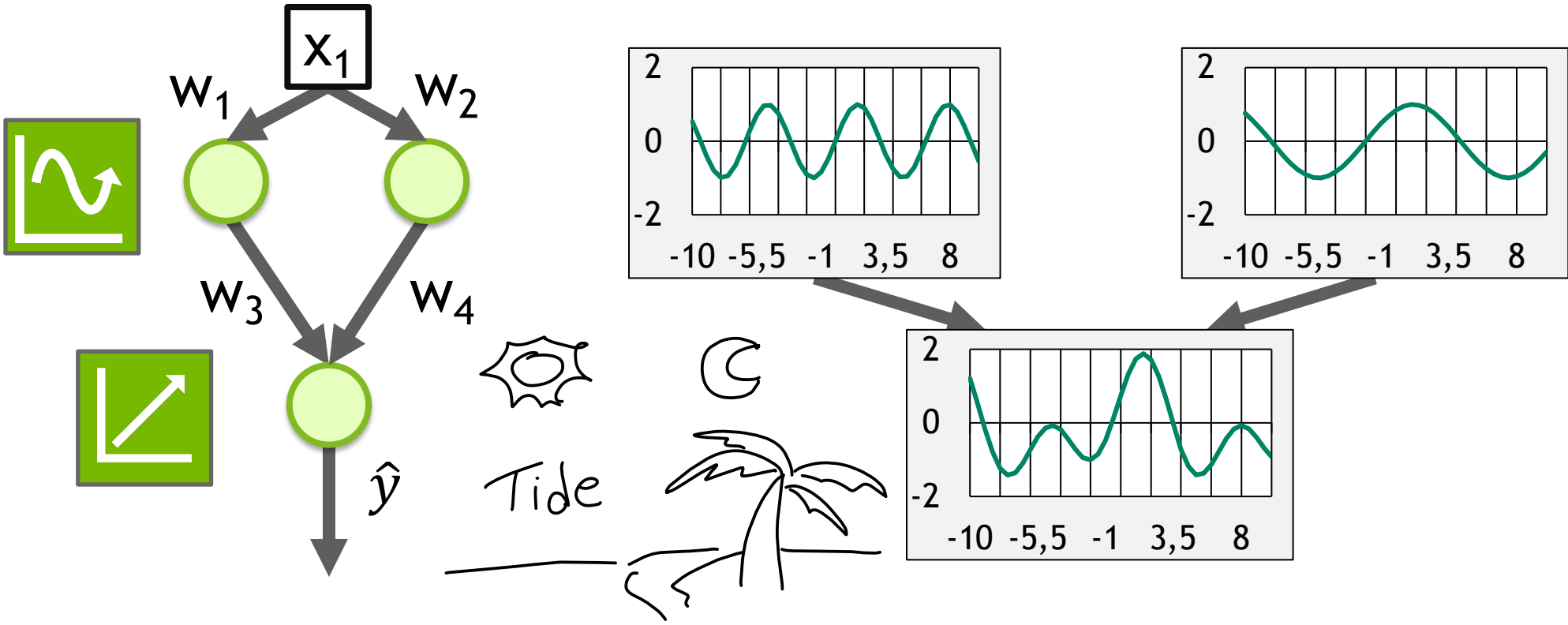



OVERFITTING

OVERFITTING

Why not have a super large neural network?

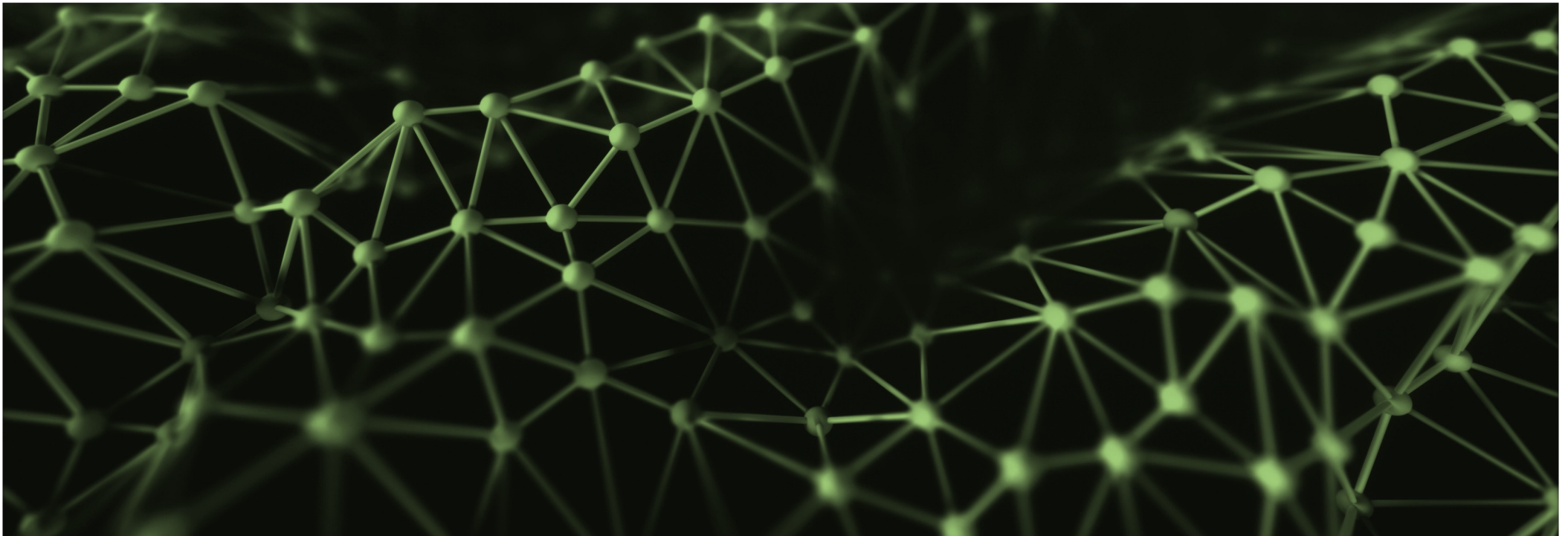

OVERFITTING

Which Trendline is Better?

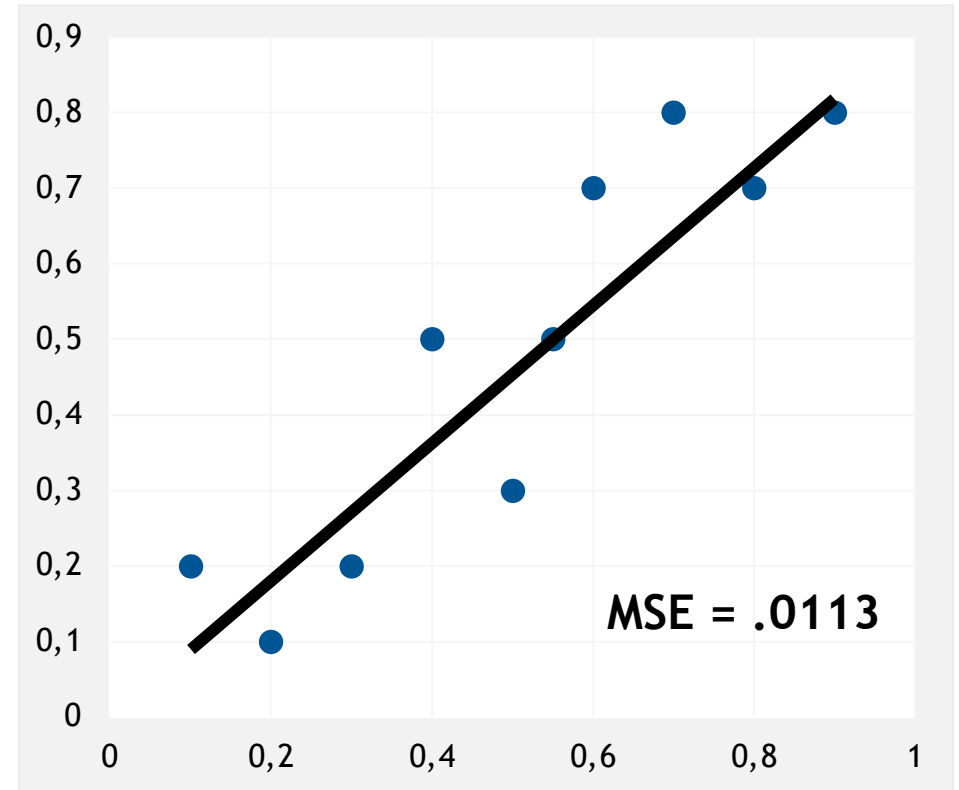
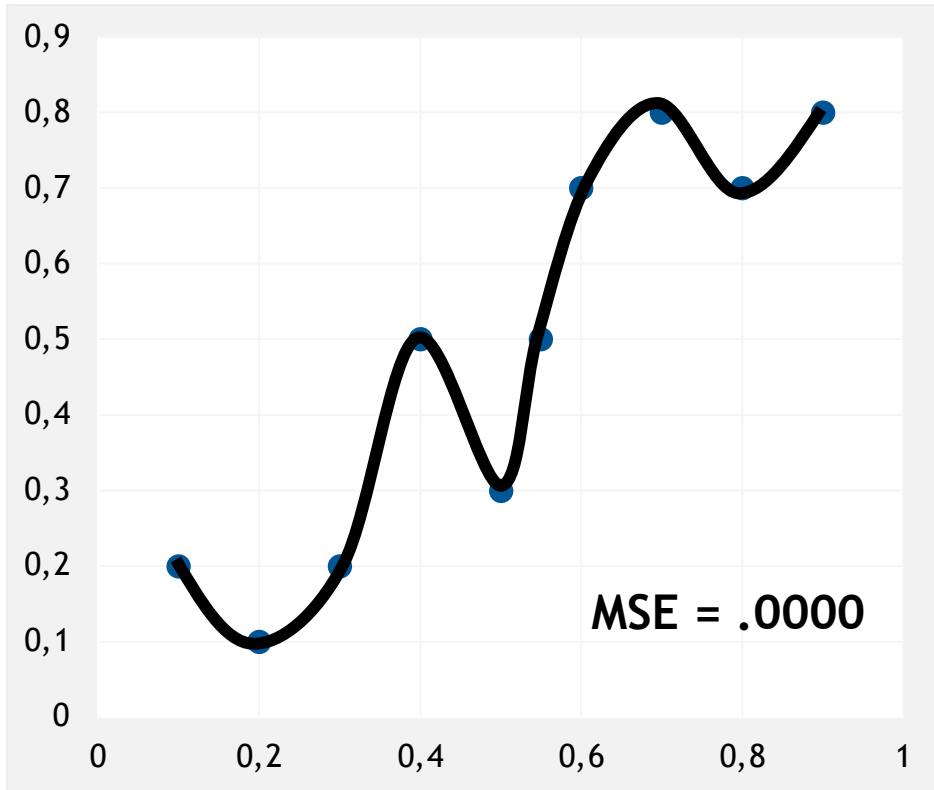

OVERFITTING

Which Trendline is Better?

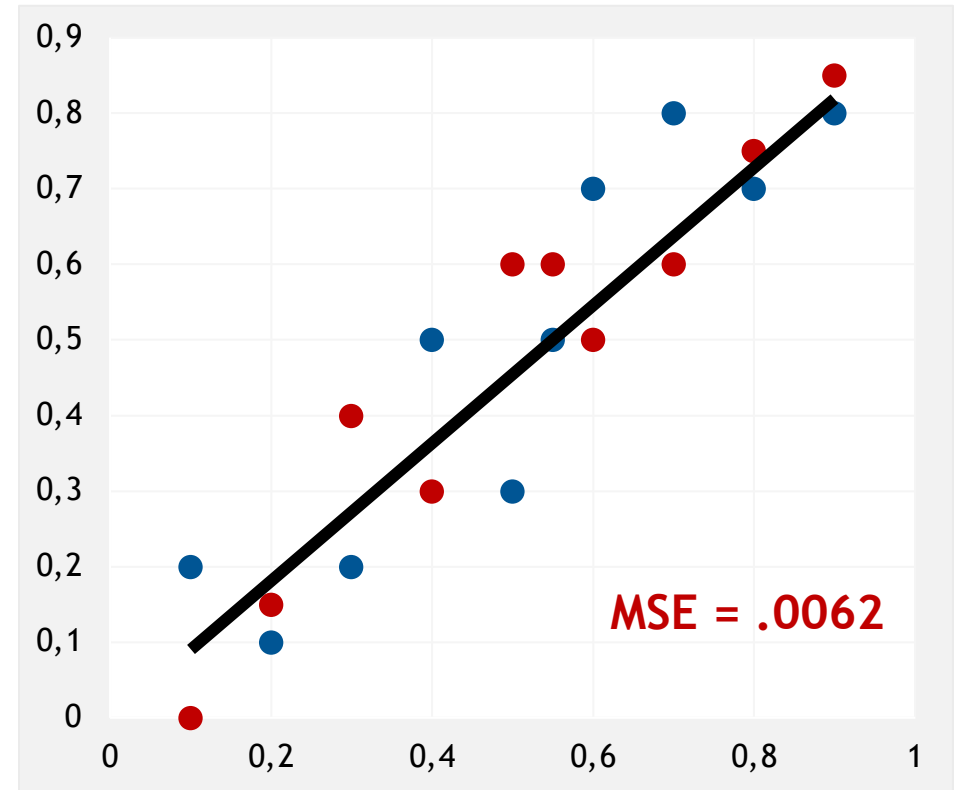
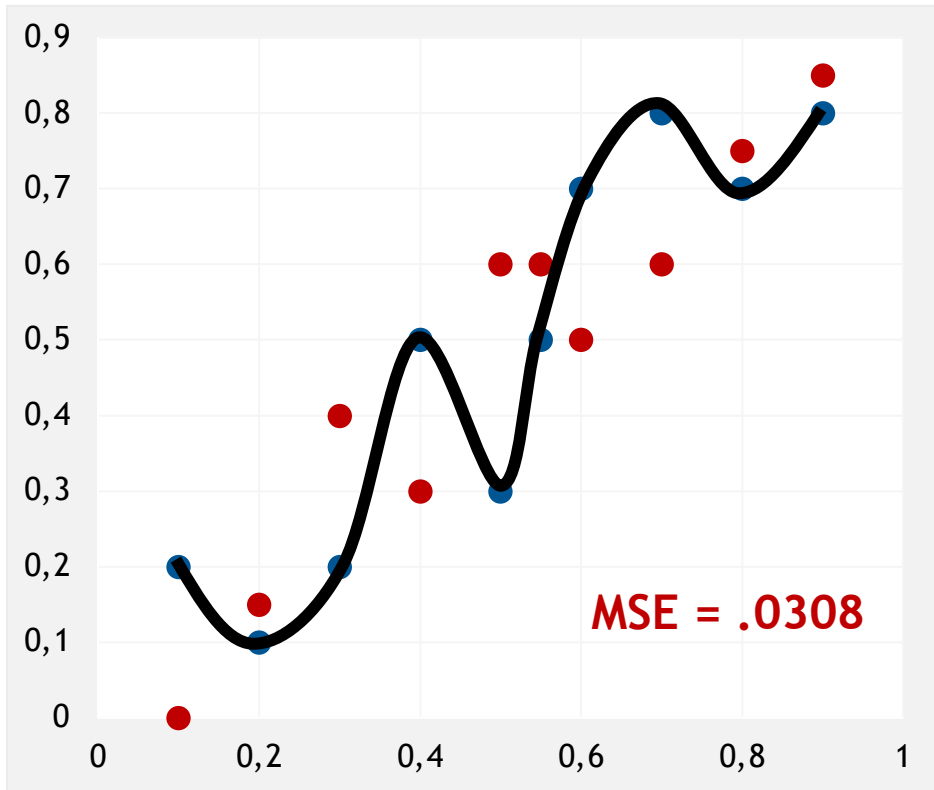

TRAINING VS VALIDATION DATA

Avoid memorization

Training data

- Core dataset for the model to learn on

Validation data

- New data for model to see if it truly understands (can generalize)

Overfitting

- When model performs well on the training data, but not the validation data (evidence of memorization)
- Ideally the accuracy and loss should be similar between both datasets

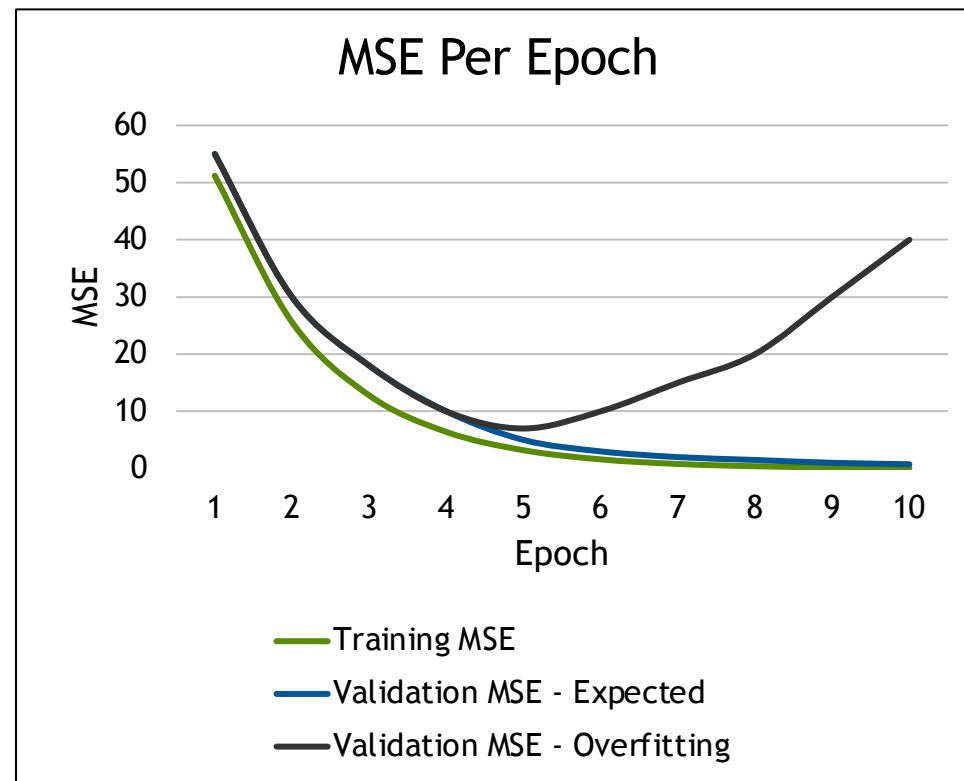



**FROM REGRESSION TO
CLASSIFICATION**

AN MNIST MODEL

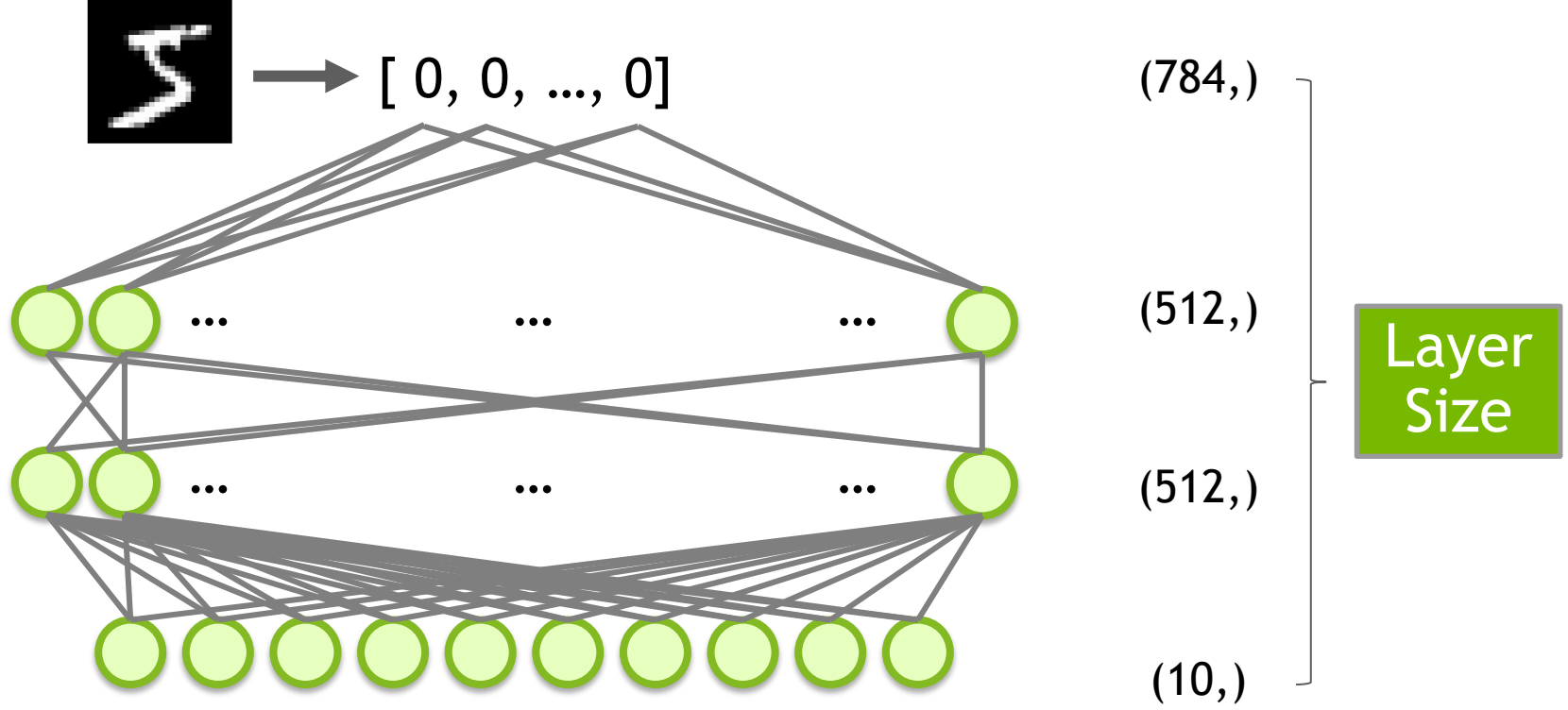

AN MNIST MODEL

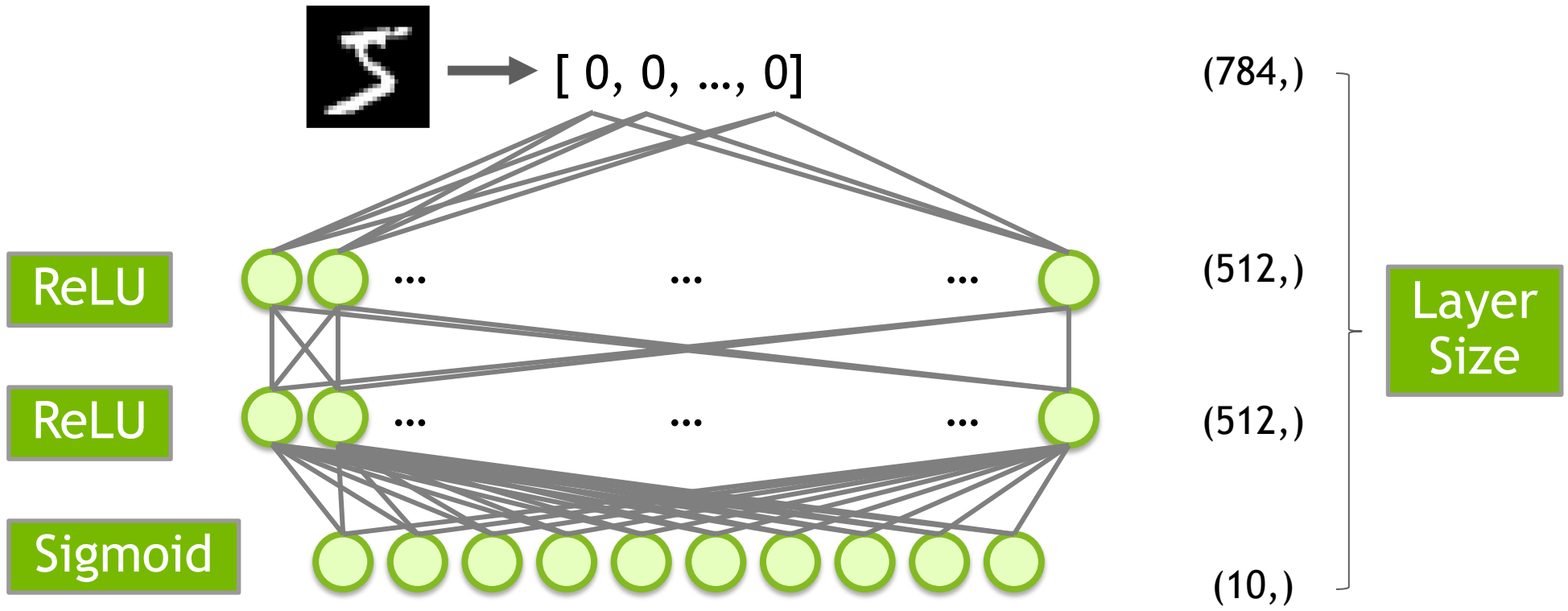

AN MNIST MODEL

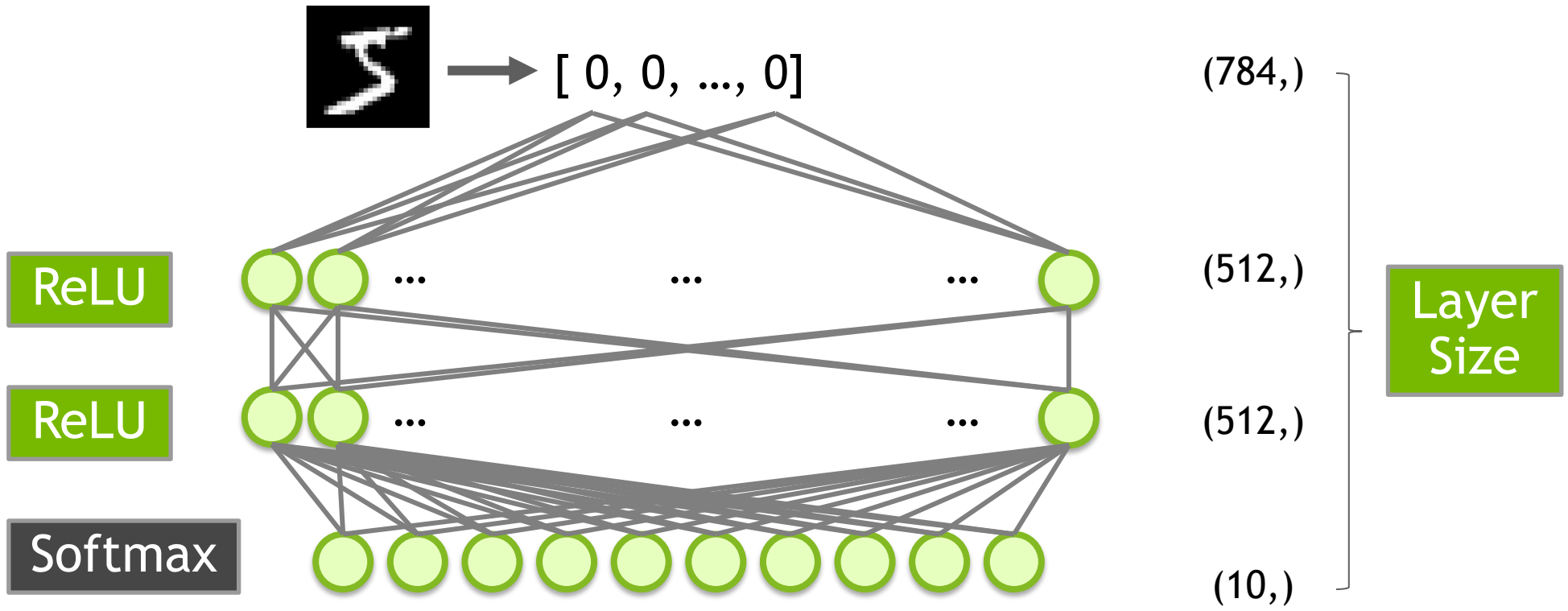

RMSE FOR PROBABILITIES?

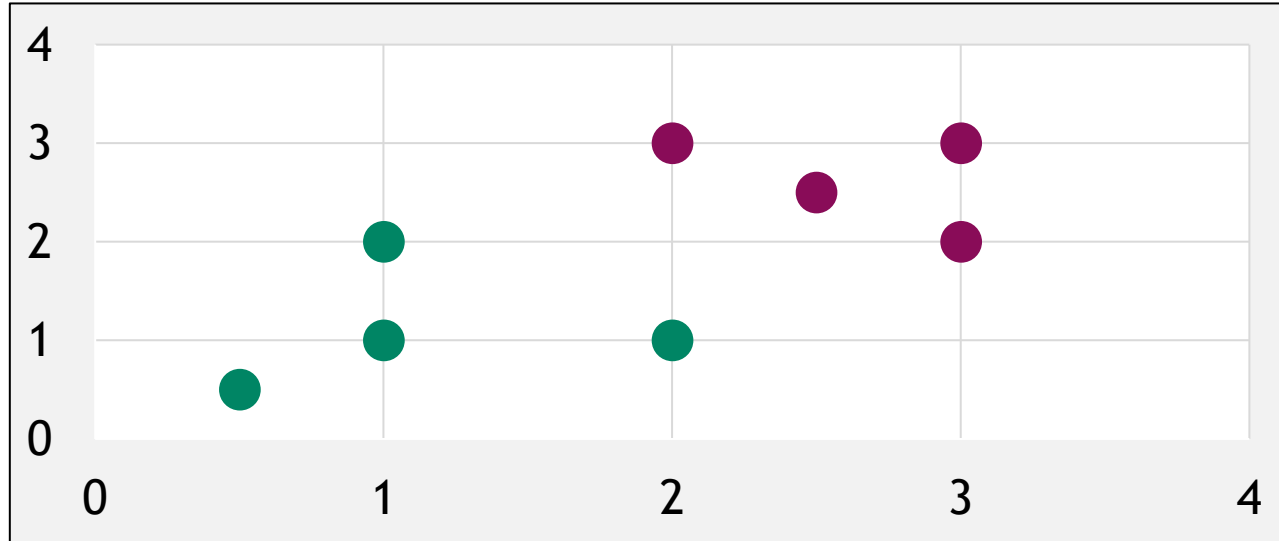

RMSE FOR PROBABILITIES?

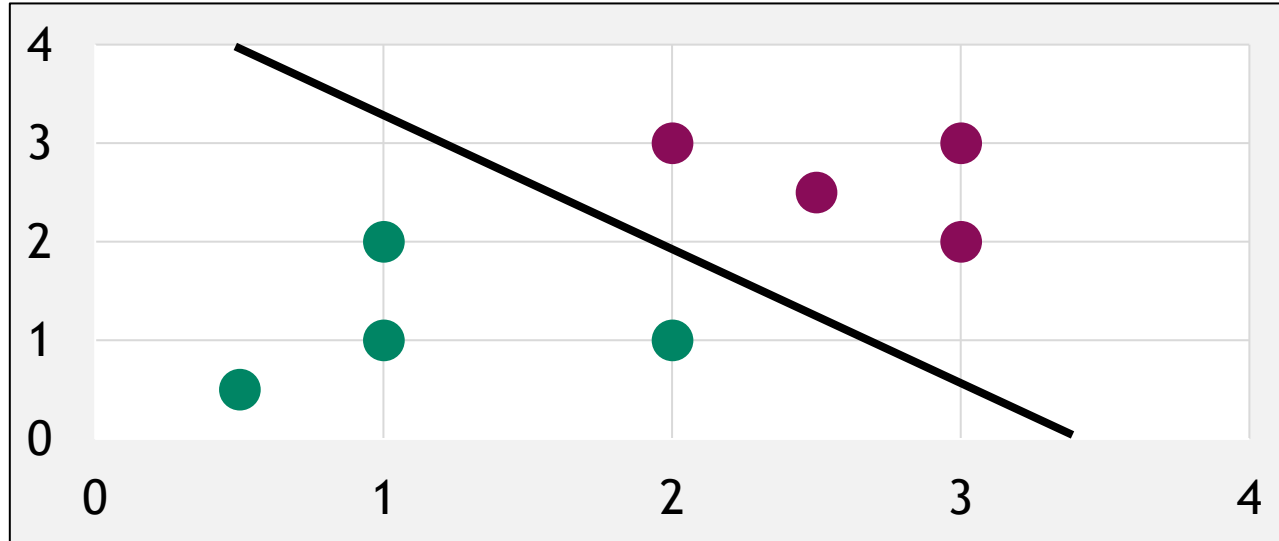

CROSS ENTROPY

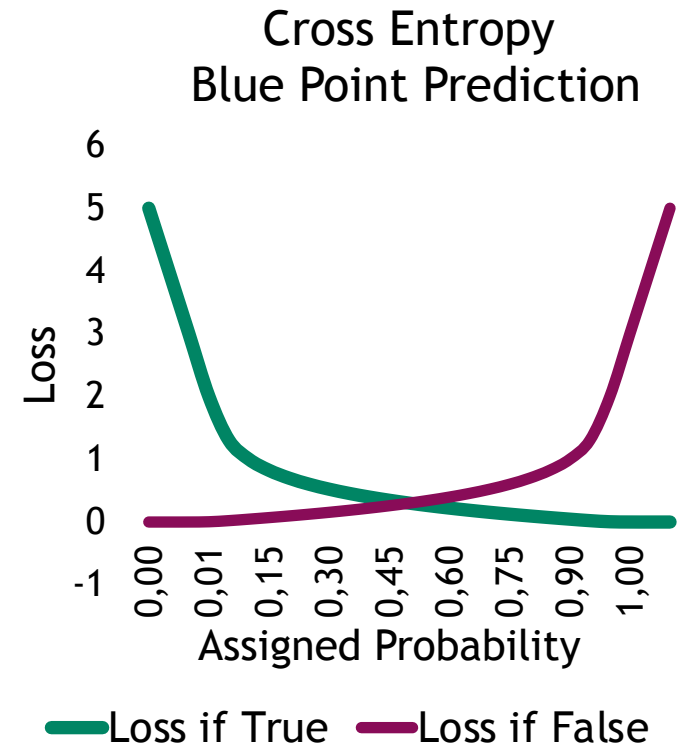
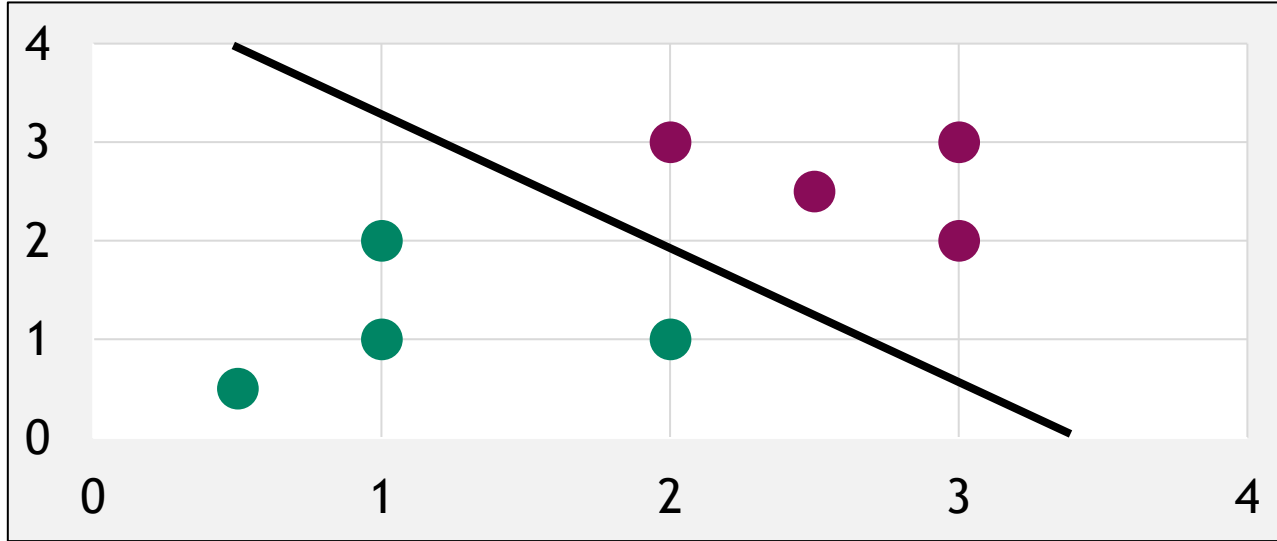

CROSS ENTROPY

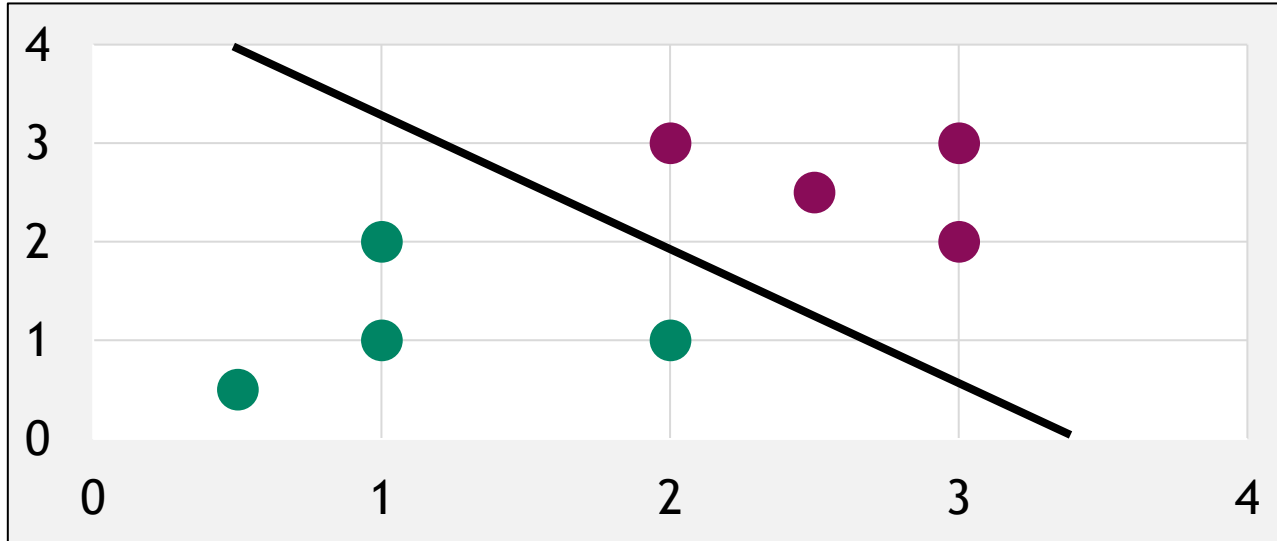

$$Loss = -((t(x) \cdot \log(p(x))) + (1 - t(x)) \cdot \log(1 - p(x)))$$

$t(x)$ = target (0 if False, 1 if True)

$p(x)$ = probability prediction of point x

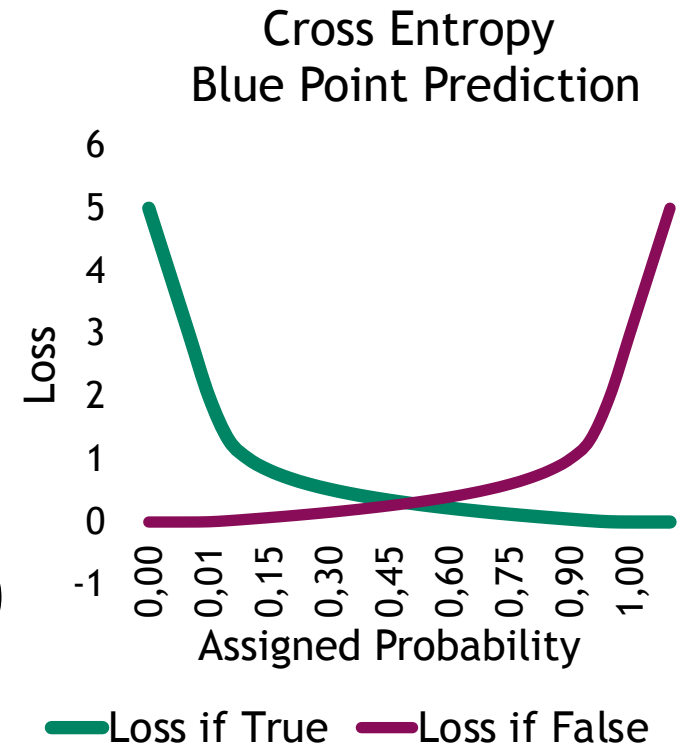

CROSS ENTROPY

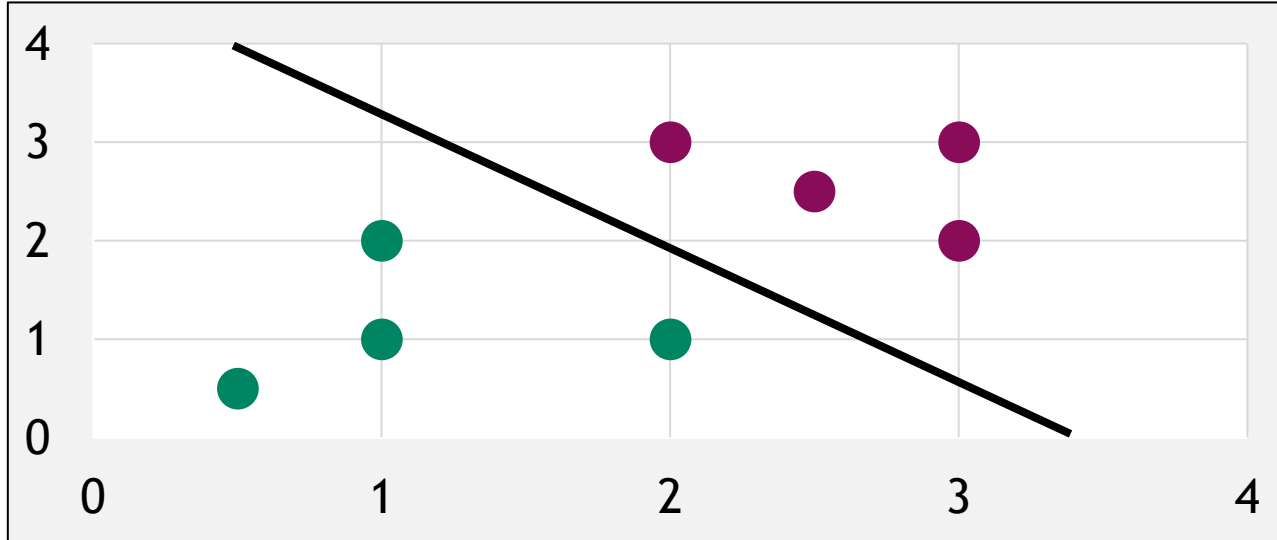

```
1 def cross_entropy(y_hat, y_actual):  
2     """Infinite error for misplaced confidence."""  
3     loss = log(y_hat) if y_actual else log(1-y_hat)  
4     return -1*loss
```

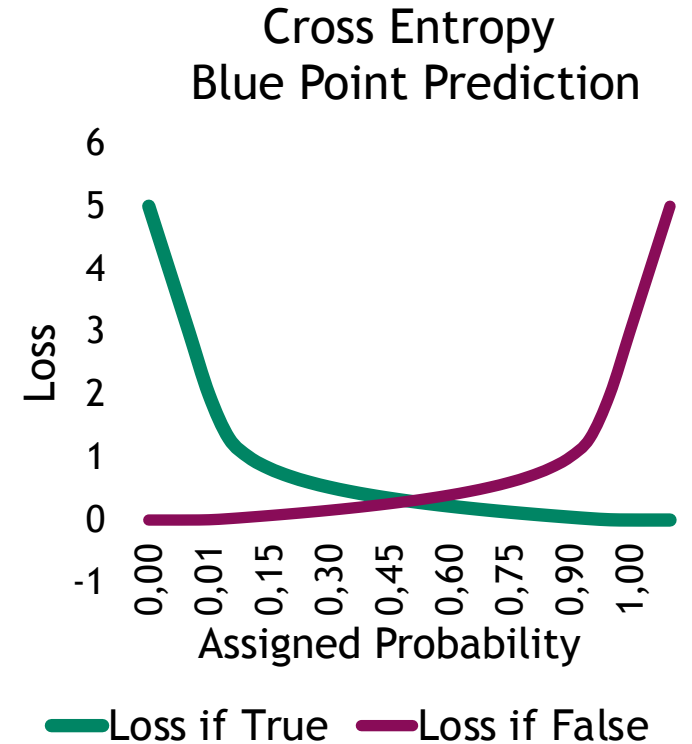



BRINGING IT TOGETHER

THE NEXT EXERCISE

The American Sign Language Alphabet

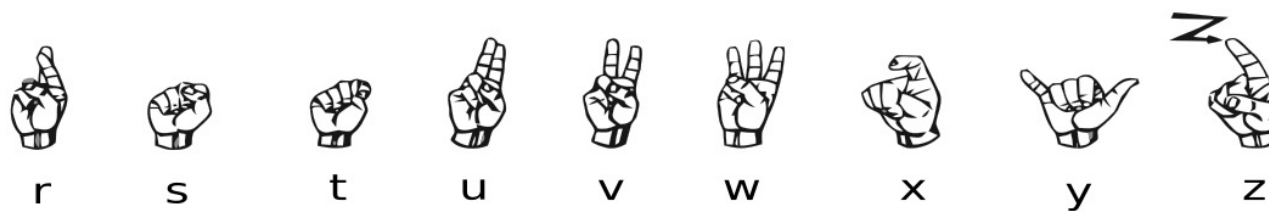
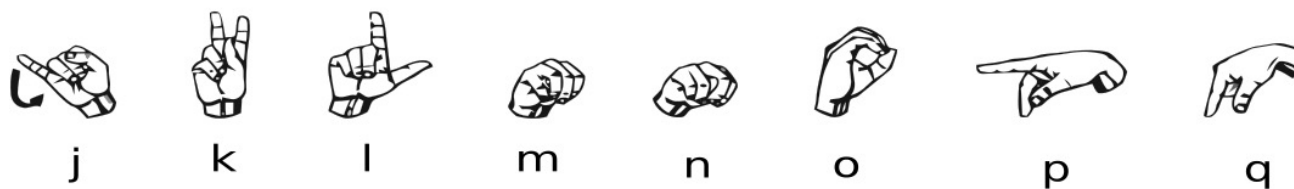
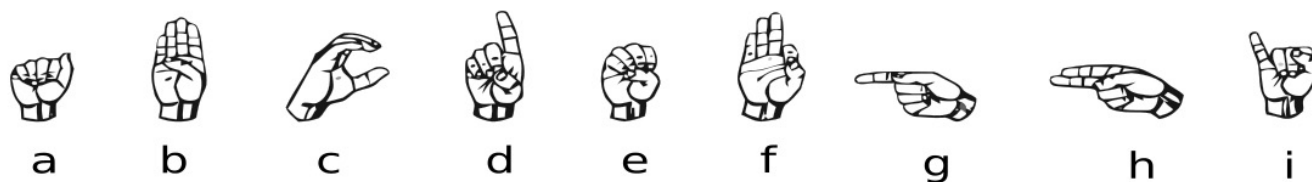



LET'S GO!



DEEP
LEARNING
INSTITUTE

APPENDIX: GRADIENT DESCENT

HELPING THE COMPUTER CHEAT CALCULUS

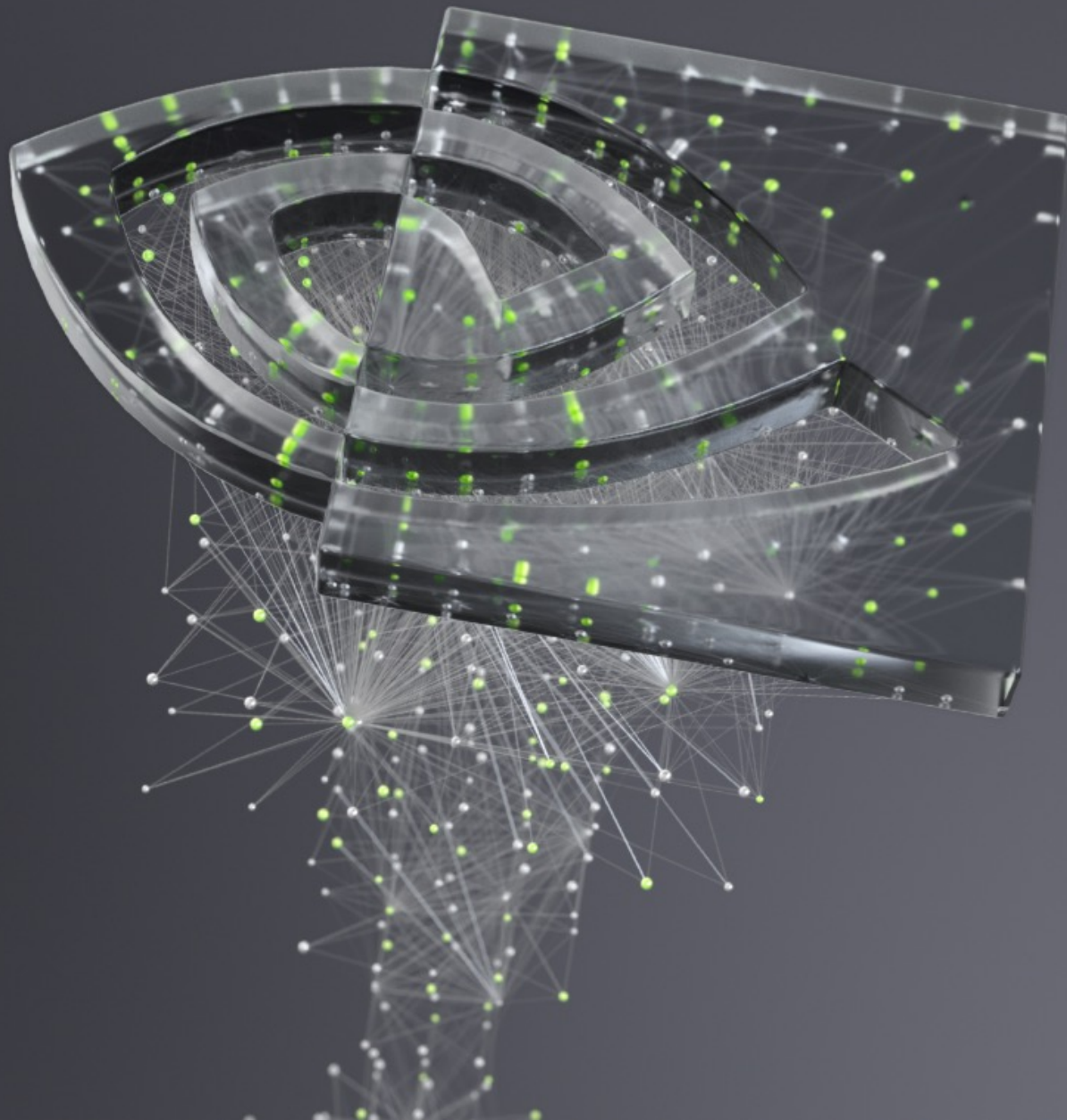

$$MSE = \frac{1}{n} \sum_{i=1}^n (y - \hat{y})^2 = \frac{1}{n} \sum_{i=1}^n (y - (mx + b))^2$$

$$MSE = \frac{1}{2} ((3 - (m(1) + b))^2 + (5 - (m(2) + b))^2)$$

$$\frac{\partial MSE}{\partial m} = 5m + 3b - 13$$

$$\frac{\partial MSE}{\partial b} = 3m + 2b - 8$$

$$\frac{\partial MSE}{\partial m} = -3$$

$$\frac{\partial MSE}{\partial b} = -1$$

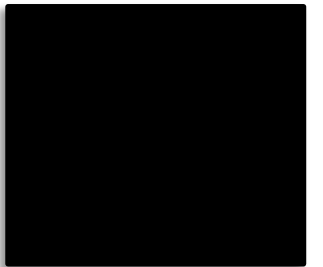

THE LOSS CURVE

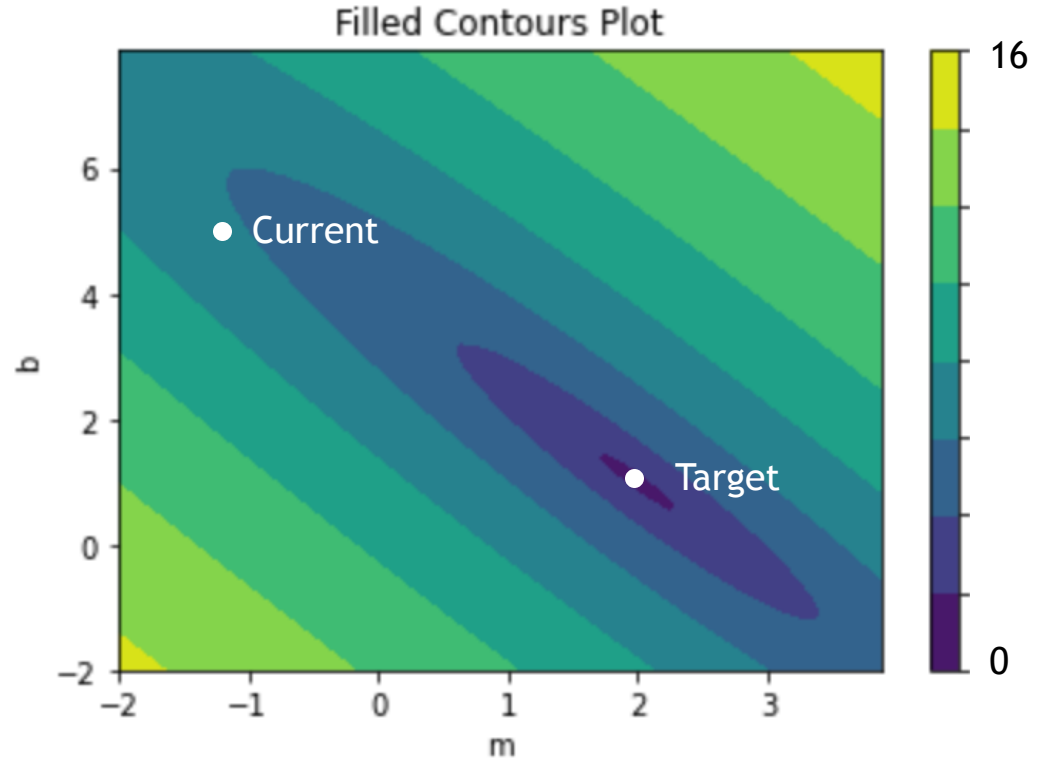
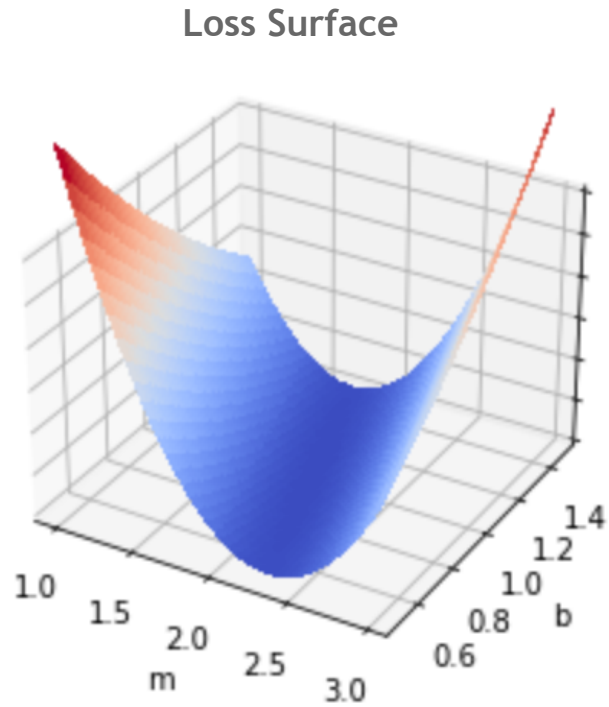

THE LOSS CURVE

$$\frac{\partial MSE}{\partial m} = -7$$

$$\frac{\partial MSE}{\partial b} = -3$$



THE LOSS CURVE

$$\frac{\partial MSE}{\partial m} = -7 \quad \frac{\partial MSE}{\partial b} = -3$$

$$m := m - \lambda \frac{\partial MSE}{\partial m}$$

$$b := b - \lambda \frac{\partial MSE}{\partial b}$$



THE LOSS CURVE

$$\frac{\partial MSE}{\partial m} = -7 \quad \frac{\partial MSE}{\partial b} = -3$$

$$m := m - \lambda \frac{\partial MSE}{\partial m}$$

$$\lambda = .6$$

$$b := b - \lambda \frac{\partial MSE}{\partial b}$$



THE LOSS CURVE

$$\frac{\partial MSE}{\partial m} = -7 \quad \frac{\partial MSE}{\partial b} = -3$$

$$m := m - \lambda \frac{\partial MSE}{\partial m}$$

$$\lambda = .005$$

$$b := b - \lambda \frac{\partial MSE}{\partial b}$$



THE LOSS CURVE

$$\lambda = .1$$

$$m := -1 + 7\lambda = -0.3$$

$$b := 5 + 3\lambda = 4.7$$

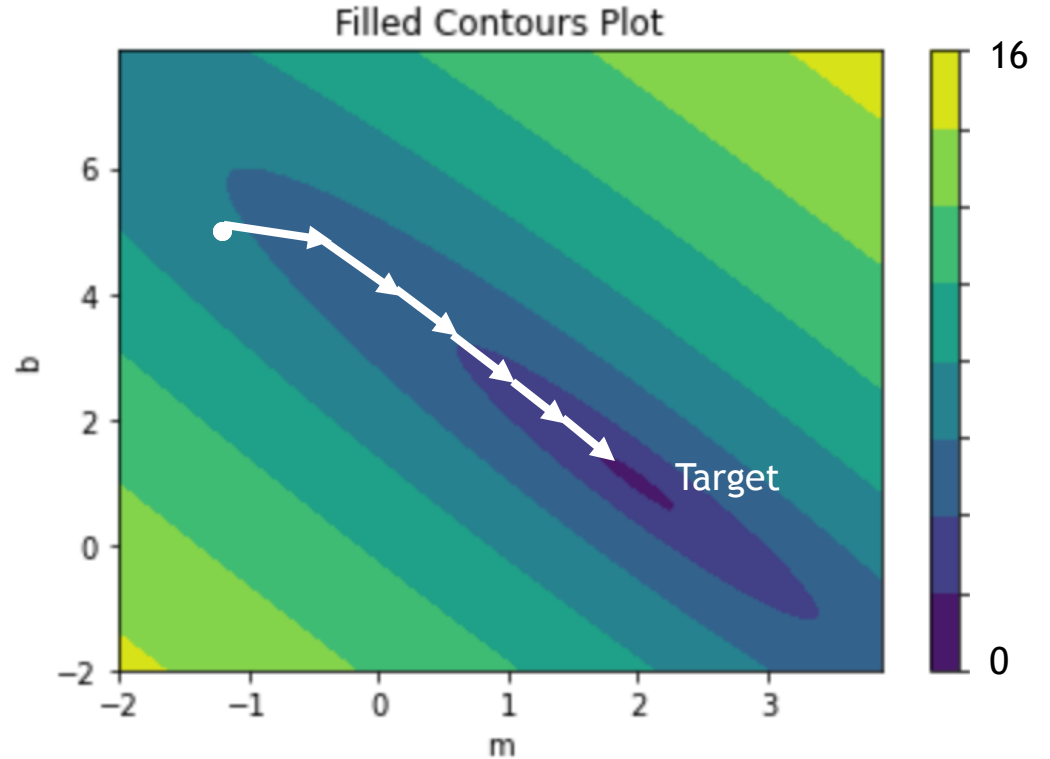

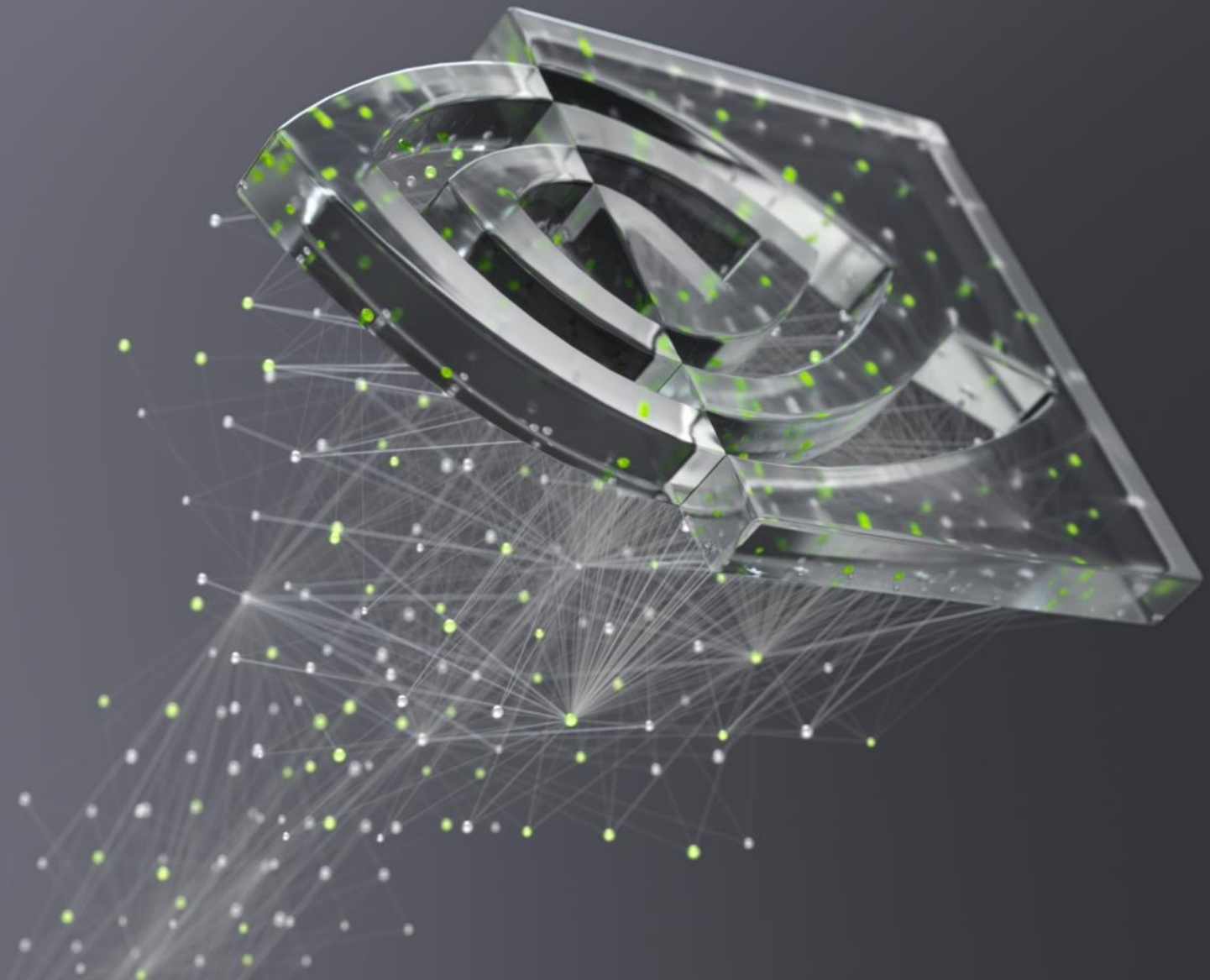

DEEP
LEARNING
INSTITUTE



DEEP
LEARNING
INSTITUTE

FUNDAMENTALS OF DEEP LEARNING

Part 3: Convolutional Neural Networks

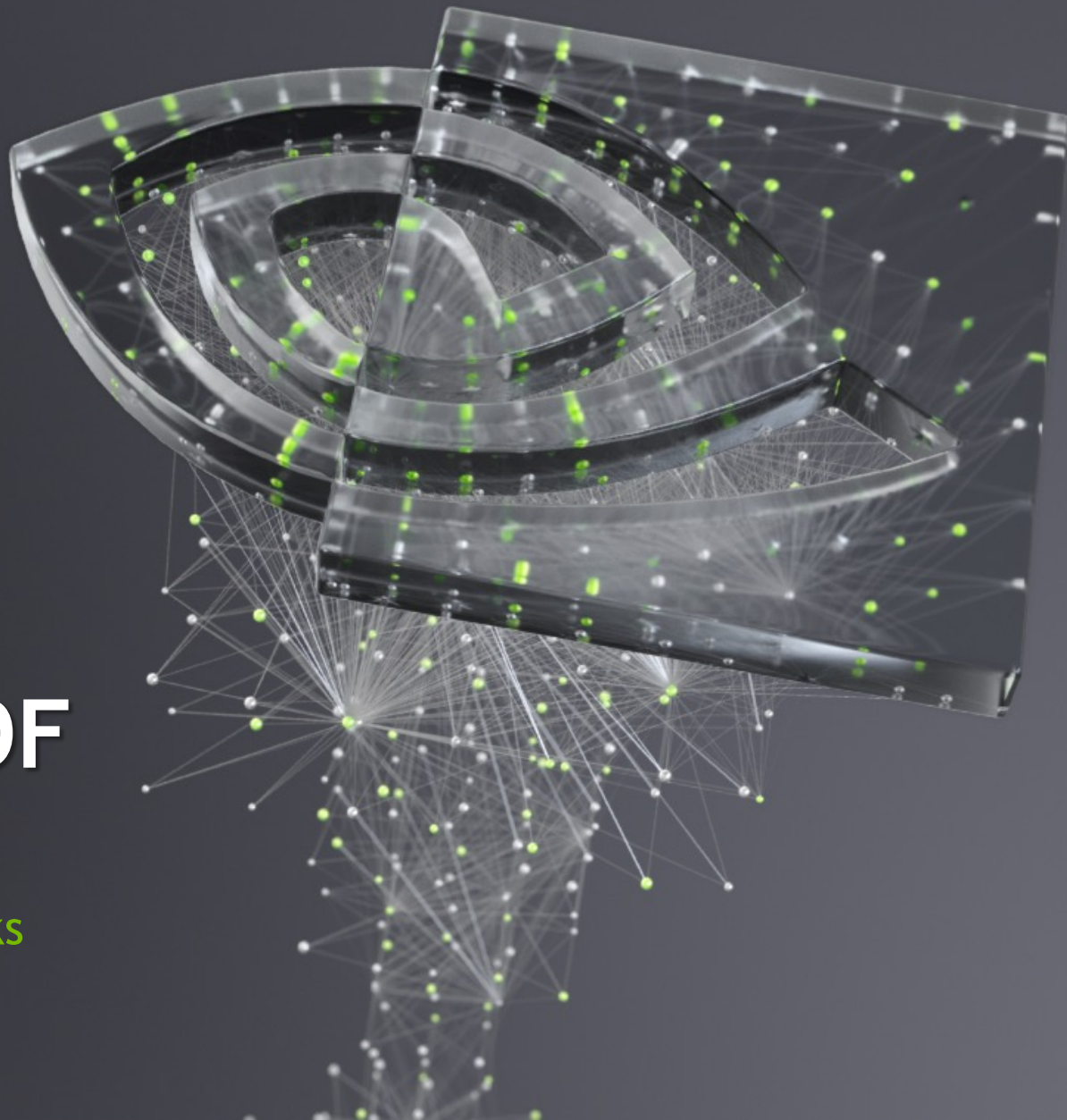

Part 1: An Introduction to Deep Learning

Part 2: How a Neural Network Trains

Part 3: Convolutional Neural Networks

Part 4: Data Augmentation and Deployment

Part 5: Pre-trained Models

Part 6: Advanced Architectures

-
-
-

RECAP OF THE EXERCISE

Trained a dense neural network model



Training accuracy was high



Validation accuracy was low



Evidence of overfitting



KERNELS AND CONVOLUTION

KERNELS AND CONVOLUTION



Original Image



KERNELS AND CONVOLUTION



Original Image

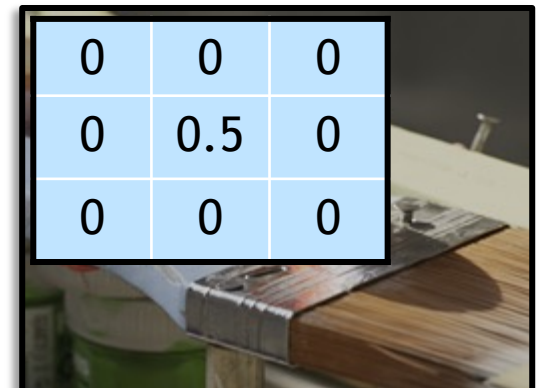
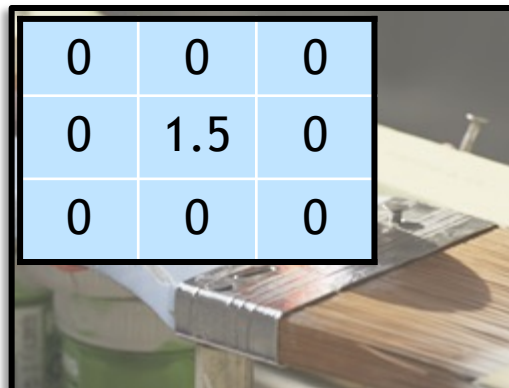
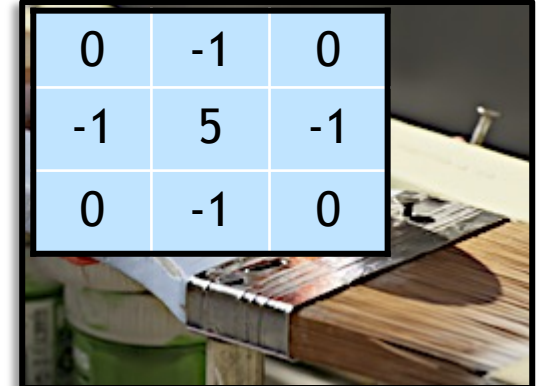
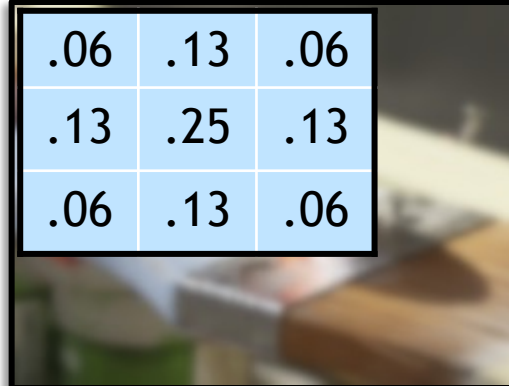

KERNELS AND CONVOLUTION

Blur Kernel

.06	.13	.06
.13	.25	.13
.06	.13	.06

*

Original Image

1	0	1	1	0	1
0	1	0	0	1	0
0	1	1	1	1	0
0	1	1	1	1	0
1	0	1	1	0	1
1	1	0	0	1	1

=

Convolved Image

KERNELS AND CONVOLUTION

Blur Kernel

.06	.13	.06
.13	.25	.13
.06	.13	.06

*

Original Image

1	0	1	1	0	1
0	1	0	0	1	0
0	1	1	1	1	0
0	1	1	1	1	0
1	0	1	1	0	1
1	1	0	0	1	1

=

Convolved Image

KERNELS AND CONVOLUTION

Blur Kernel

Original Image

Convolved Image

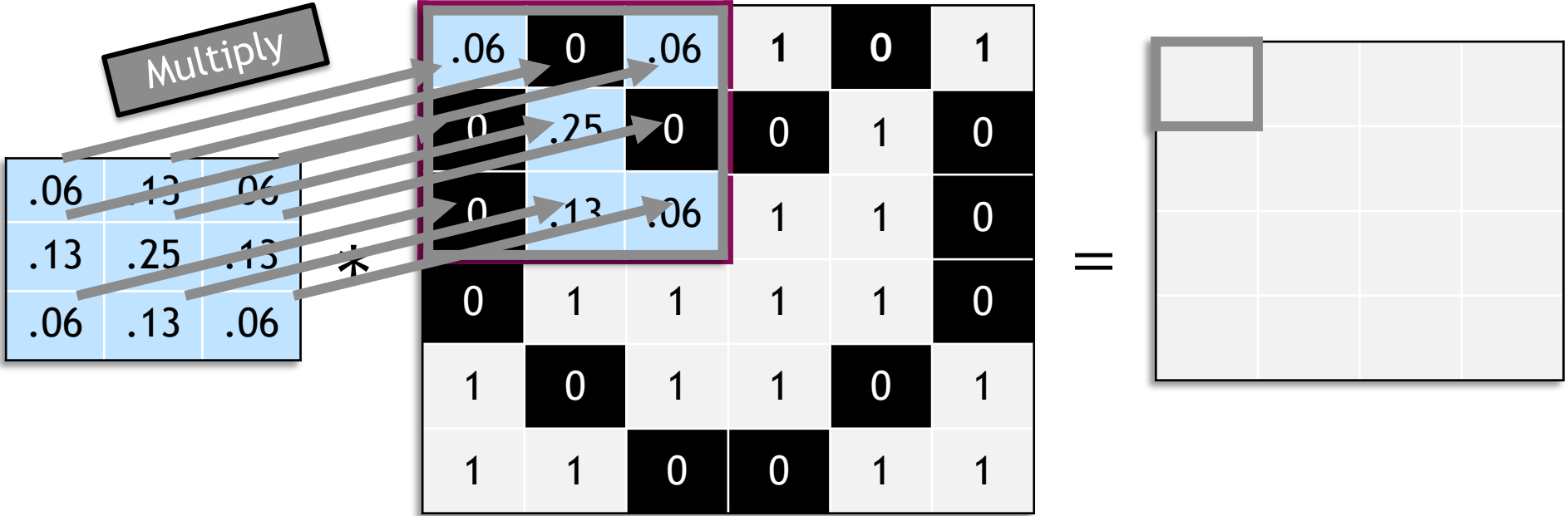

KERNELS AND CONVOLUTION

Blur Kernel

.06	.13	.06
.13	.25	.13
.06	.13	.06

*

Original Image

.06	0	.06	1	0	1
0	.25	0	0	1	0
0	.13	.06	1	1	0
0	1	1	1	0	0
1	0	1	1	0	1
1	1	0	0	1	1

Total

=

Convolved Image

.56			

KERNELS AND CONVOLUTION

Blur Kernel

.06	.13	.06
.13	.25	.13
.06	.13	.06

*

Original Image

1	0	.13	.06	0	1
0	.13	0	0	1	0
0	.06	.13	.06	1	0
0	1	1	1	1	0
1	0	1	1	0	1
1	1	0	0	1	1

=

Convolved Image

.56	.57		

KERNELS AND CONVOLUTION

Blur Kernel

.06	.13	.06
.13	.25	.13
.06	.13	.06

*

Original Image

1	0	1	1	0	1
0	1	0	0	1	0
0	1	1	1	1	0
0	1	1	1	1	0
1	0	1	1	0	1
1	1	0	0	1	1

=

Convolved Image

.56	.57	.57	.56
.7	.82	.82	.7
.69	.95	.95	.69
.64	.69	.69	.64

STRIDE

Stride 1

1	0	1	1	0	1
0	1	0	0	1	0
0	1	1	1	1	0

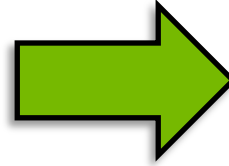

.56	.57	.57	.56
-----	-----	-----	-----

Stride 2

1	0	1	1	0	1
0	1	0	0	1	0
0	1	1	1	1	0

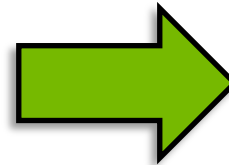

.56	.57
-----	-----

Stride 3

1	0	1	1	0	1
0	1	0	0	1	0
0	1	1	1	1	0

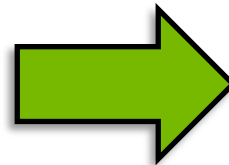

.56	.56
-----	-----

PADDING

Original Image

1	0	1	1	0	1
0	1	0	0	1	0
0	1	1	1	1	0
0	1	1	1	1	0
1	0	1	1	0	1
1	1	0	0	1	1

Zero Padding

0	0	0	0	0	0	0	0
0	1	0	1	1	0	1	0
0	0	1	0	0	1	0	0
0	0	1	1	1	1	0	0
0	0	1	1	1	1	0	0
0	1	0	1	1	0	1	0
0	1	1	0	0	1	1	0
0	0	0	0	0	0	0	0

PADDING

Original Image

1	0	1	1	0	1
0	1	0	0	1	0
0	1	1	1	1	0
0	1	1	1	1	0
1	0	1	1	0	1
1	1	0	0	1	1

Mirror Padding

1	1	0	1	1	0	1	1
1	1	0	1	1	0	1	1
0	0	1	0	0	1	0	0
0	0	1	1	1	1	0	0
0	0	1	1	1	1	0	0
1	1	0	1	1	0	1	1
1	1	1	0	0	1	1	1
1	1	1	0	0	1	1	1



KERNELS AND NEURAL NETWORKS

KERNELS AND NEURAL NETWORKS

Kernel

W_1	W_2	W_3
W_4	W_5	W_6
W_7	W_8	W_9

KERNELS AND NEURAL NETWORKS

Kernel

W_1	W_2	W_3
W_4	W_5	W_6
W_7	W_8	W_9

Neuron

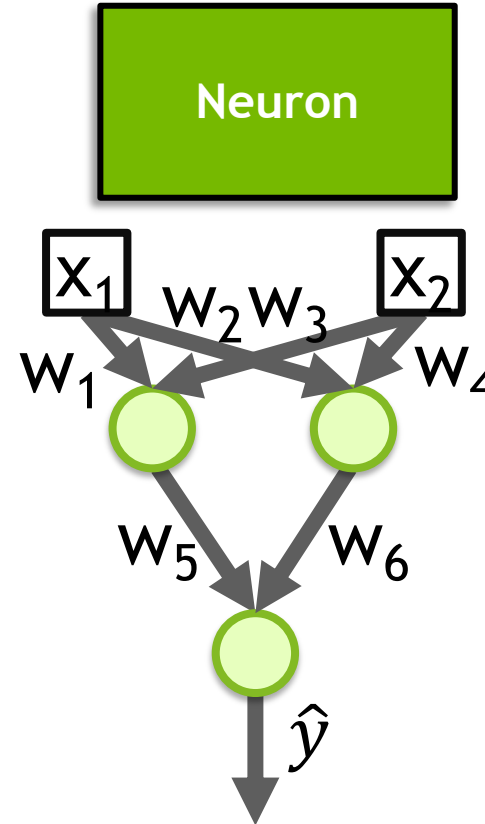

KERNELS AND NEURAL NETWORKS

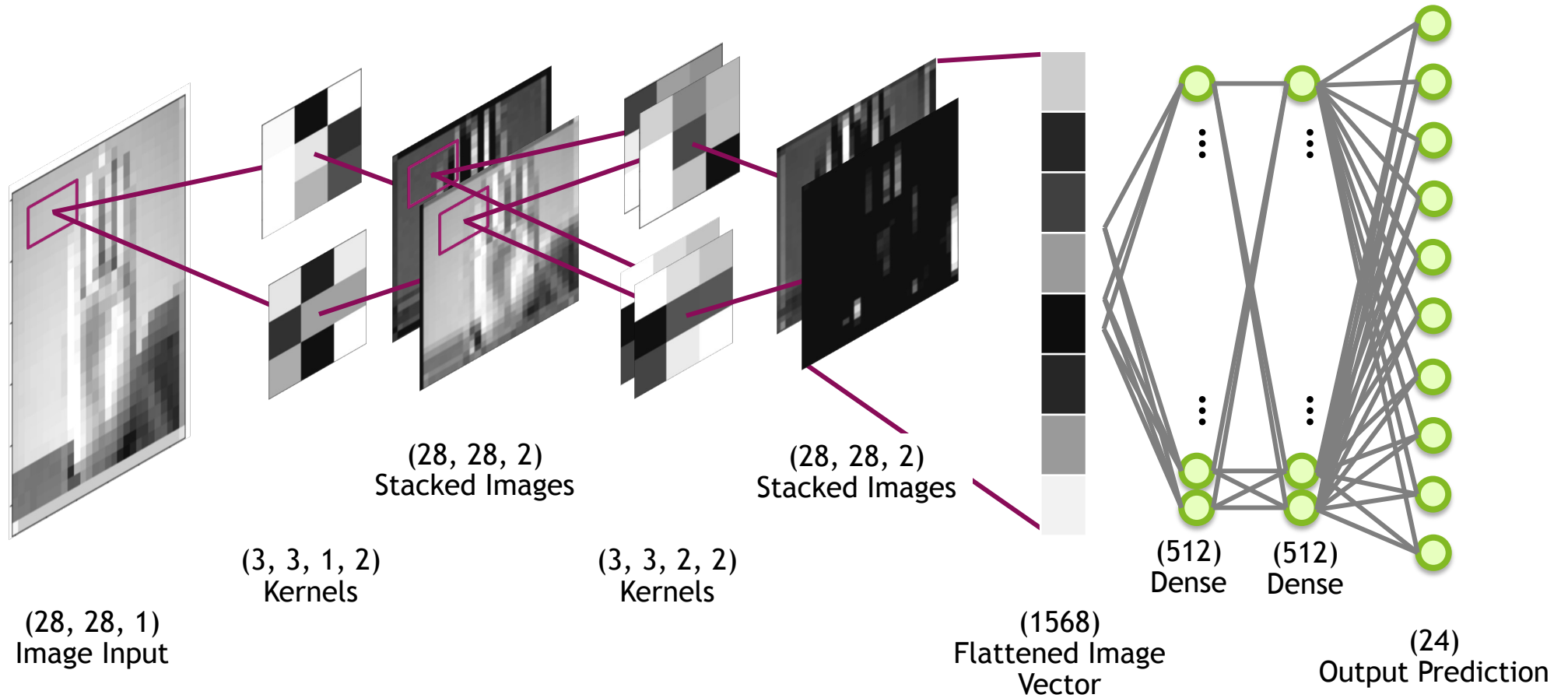

FINDING EDGES

Vertical Edges

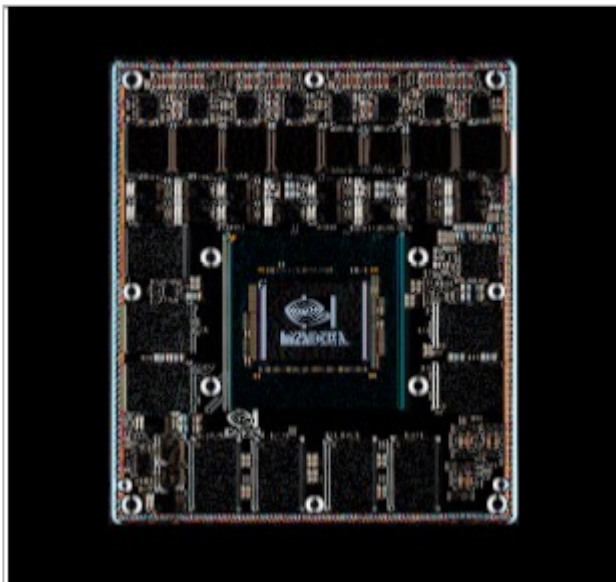

1	0	-1
2	0	-2
1	0	-1

Original Image

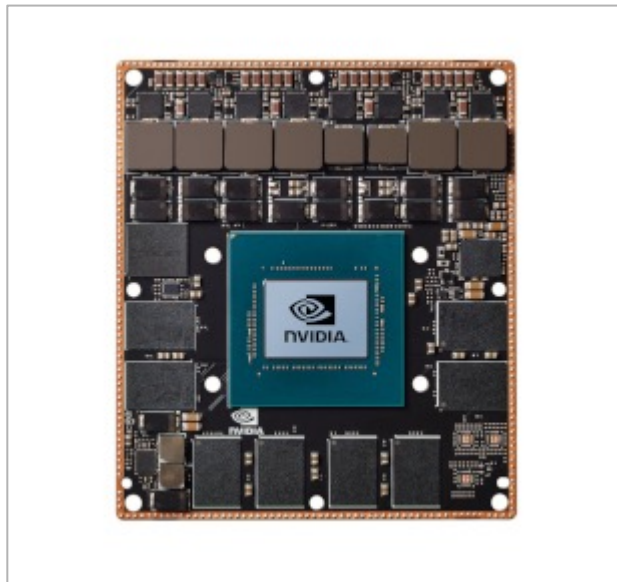

0	0	0
0	1	0
0	0	0

Horizontal Edges

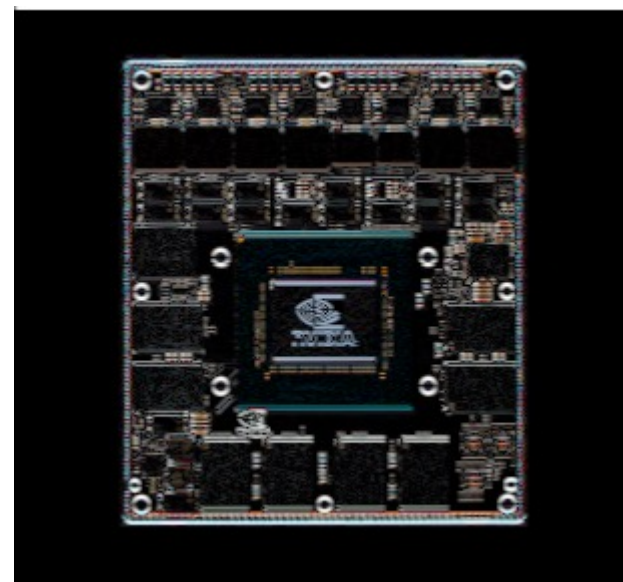

1	2	1
0	0	0
-1	-2	-1

NEURAL NETWORK PERCEPTION

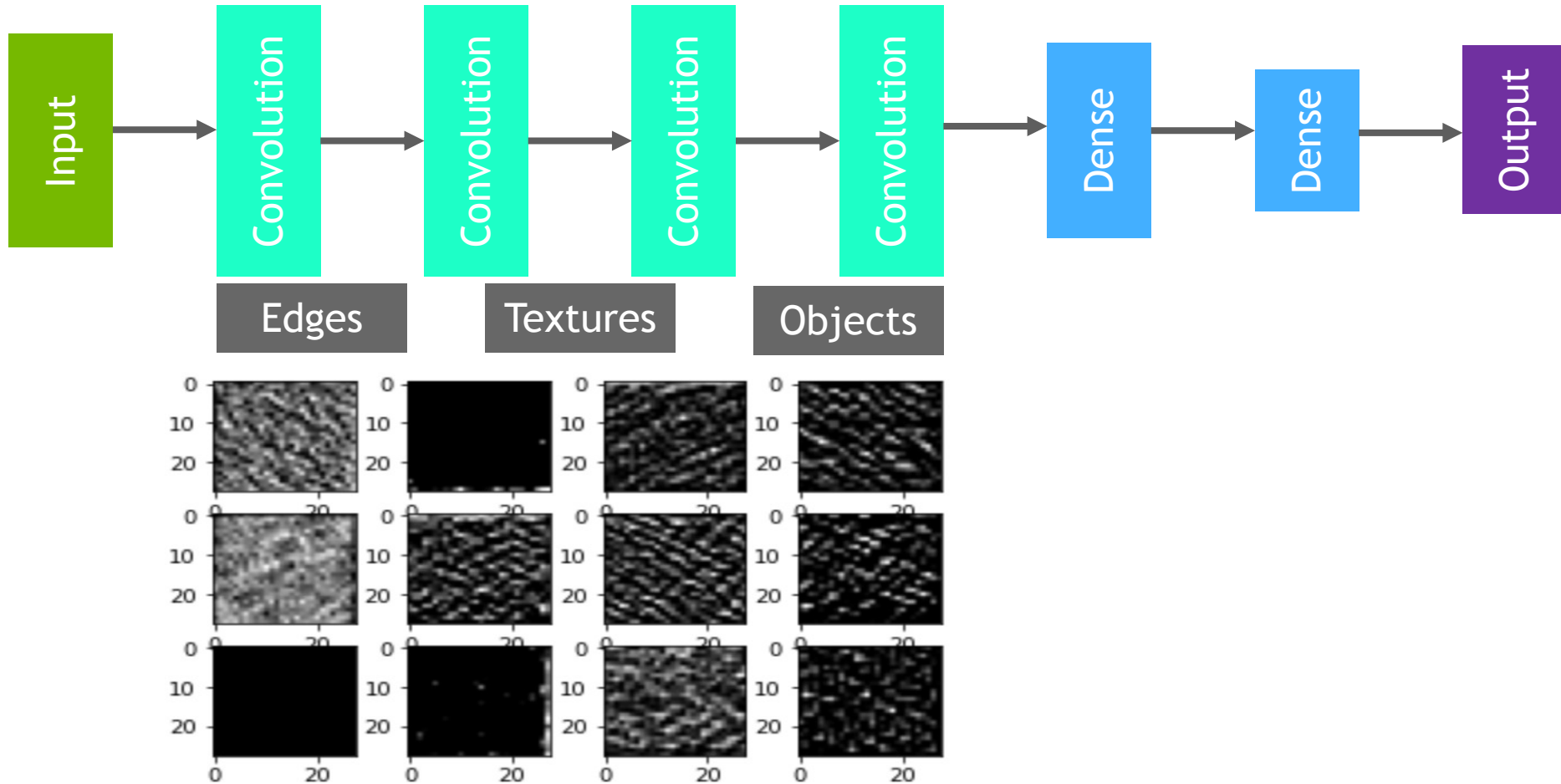

NEURAL NETWORK PERCEPTION





OTHER LAYERS IN THE
MODEL

MAX POOLING

110	256	153	67
12	89	88	43
10	15	50	55
23	9	49	23

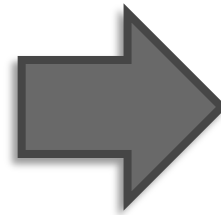

256	153
23	55

DROPOUT

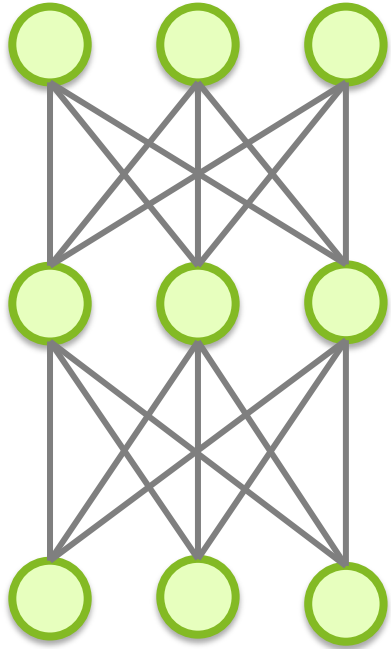

rate = 0

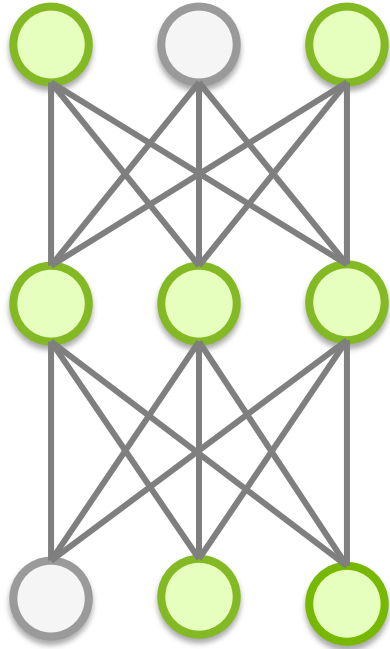

rate = .2

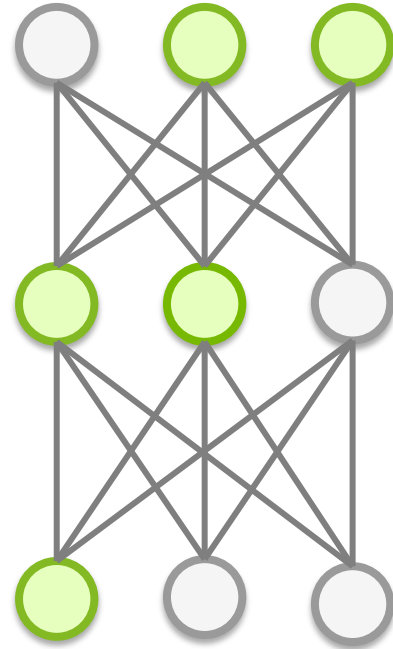

rate = .4

WHOLE ARCHITECTURE

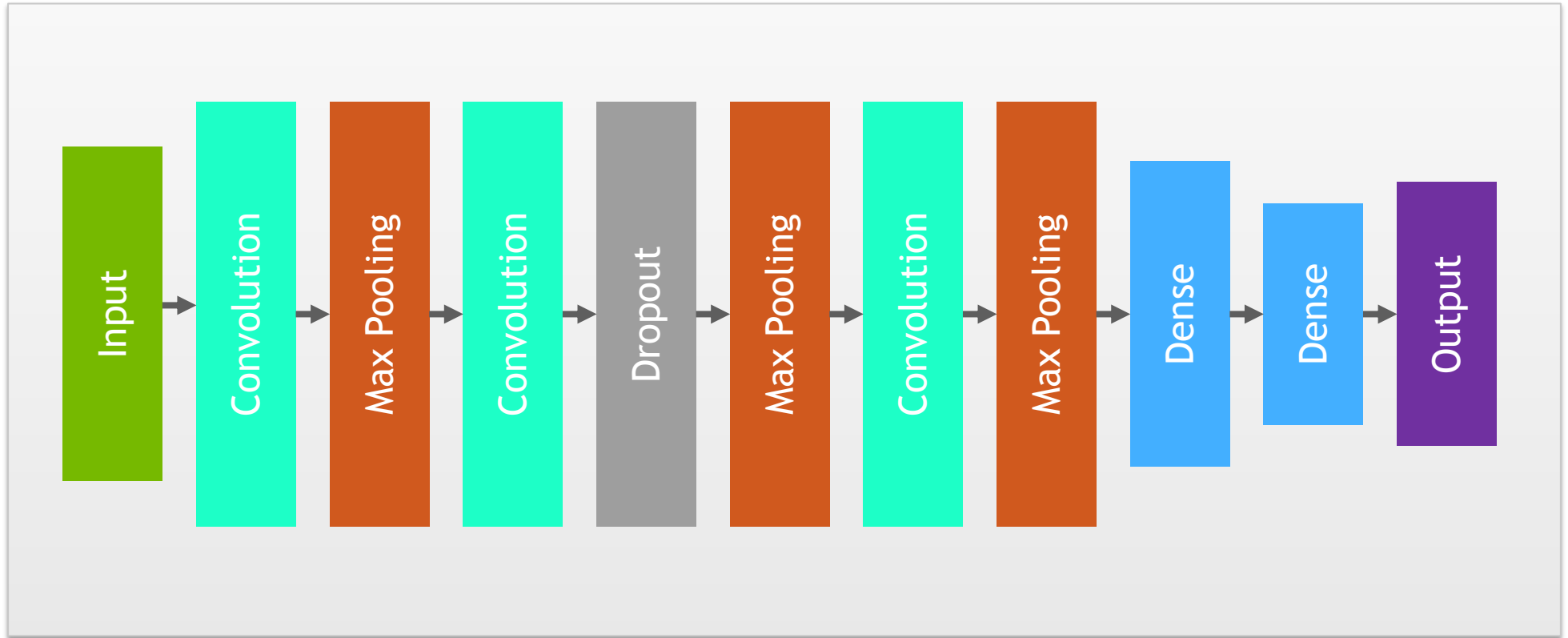



LET'S GO!

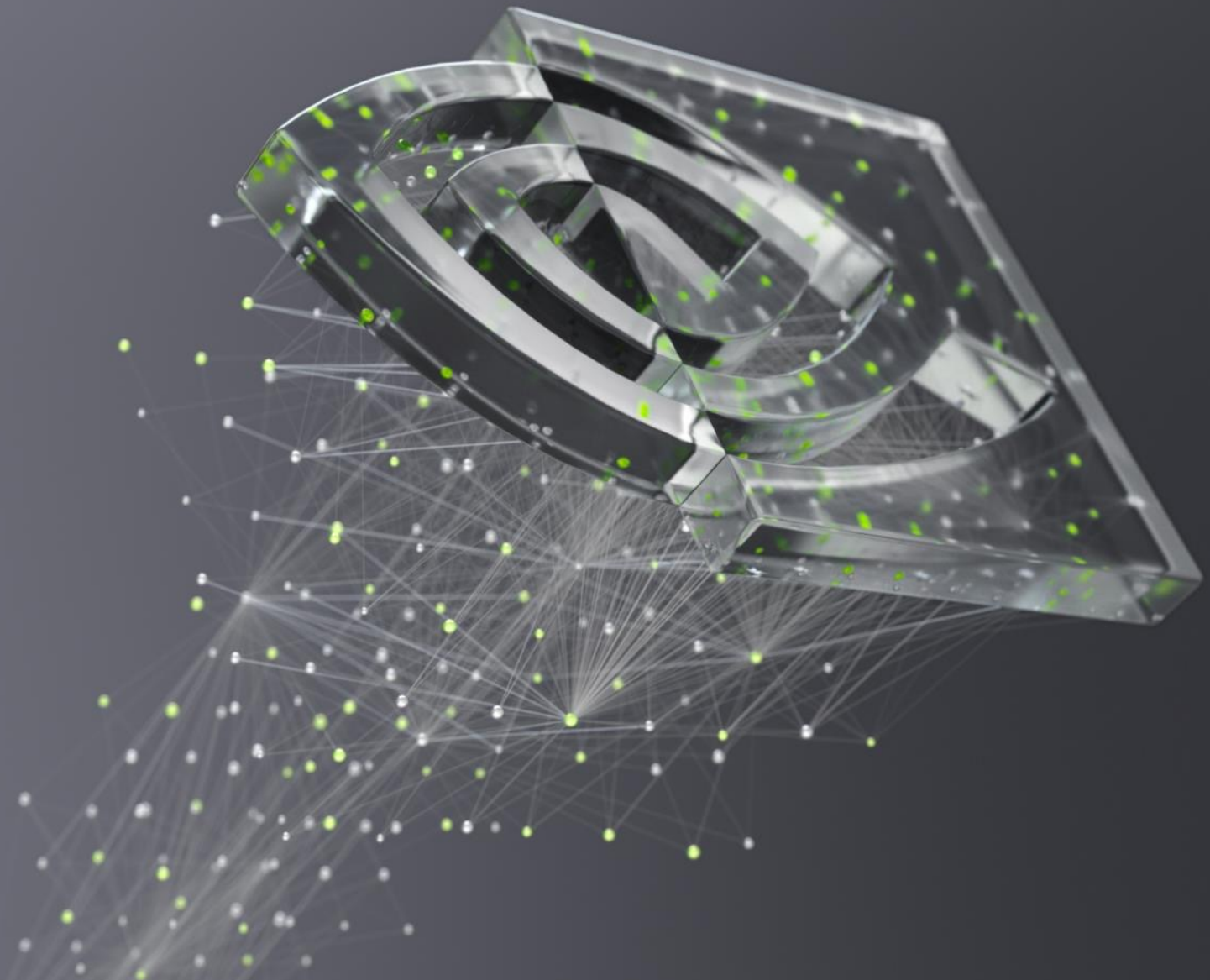

DEEP
LEARNING
INSTITUTE



DEEP
LEARNING
INSTITUTE

FUNDAMENTALS OF DEEP LEARNING

Part 4: Data Augmentation and Deployment

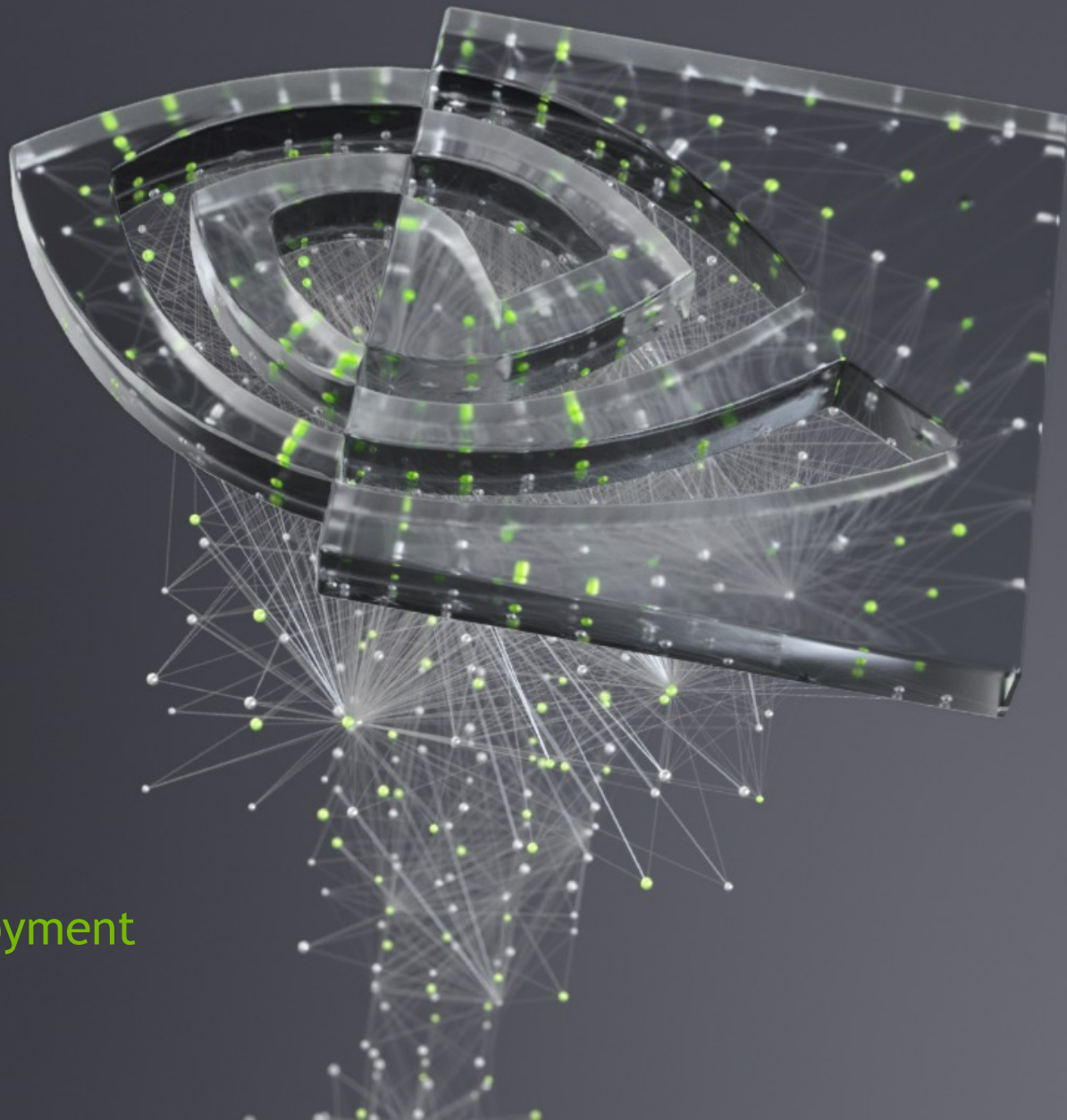

Part 1: An Introduction to Deep Learning

Part 2: How a Neural Network Trains

Part 3: Convolutional Neural Networks

Part 4: Data Augmentation and Deployment

Part 5: Pre-trained Models

Part 6: Advanced Architectures

-

-

RECAP OF THE EXERCISE

Analysis

- CNN increased validation accuracy
- Still seeing training accuracy higher than validation

Solution

- Clean data provides better examples
- Dataset variety helps the model generalize





DATA AUGMENTATION

DATA AUGMENTATION



IMAGE FLIPPING

Horizontal Flip



Vertical Flip



ROTATION

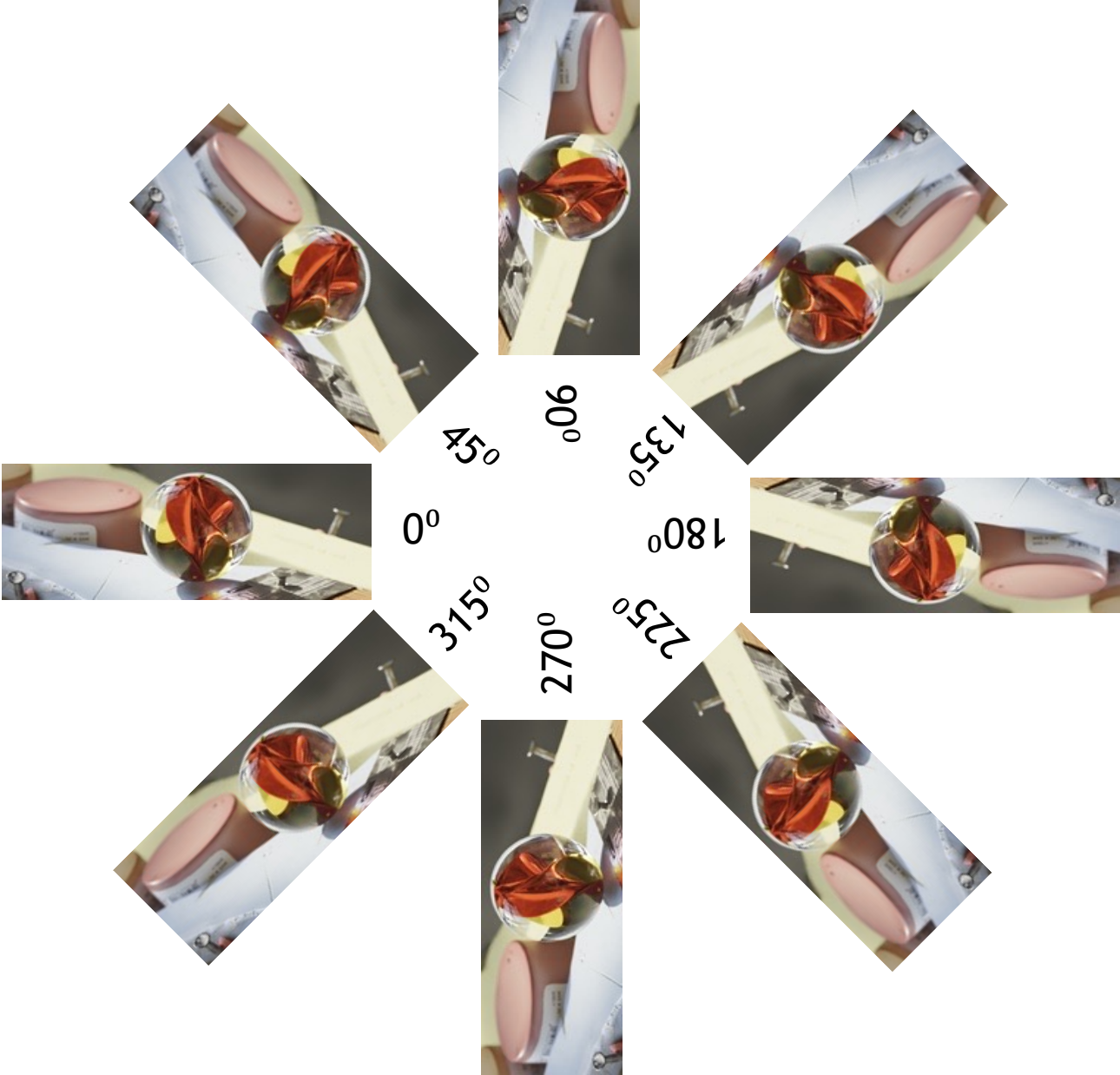

ZOOMING

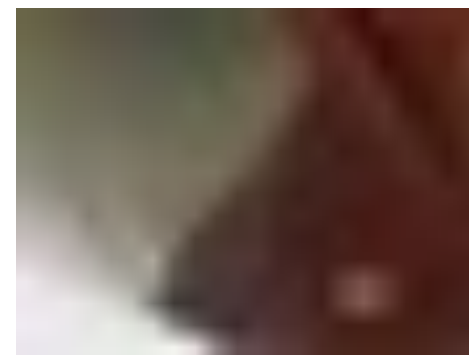
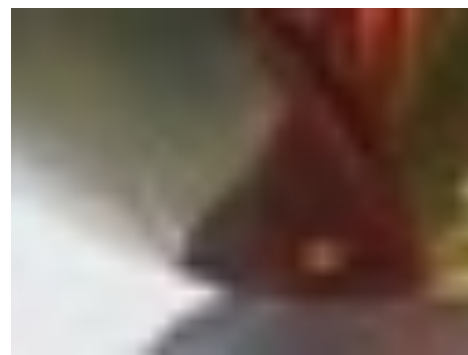
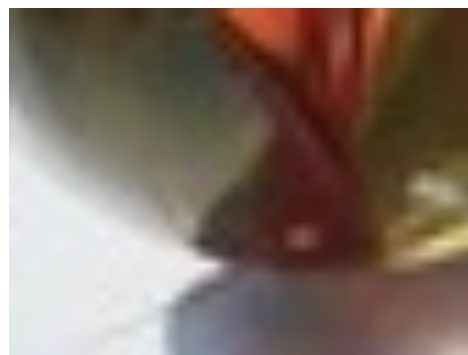

WIDTH AND HEIGHT SHIFTING



HOMOGRAPHY

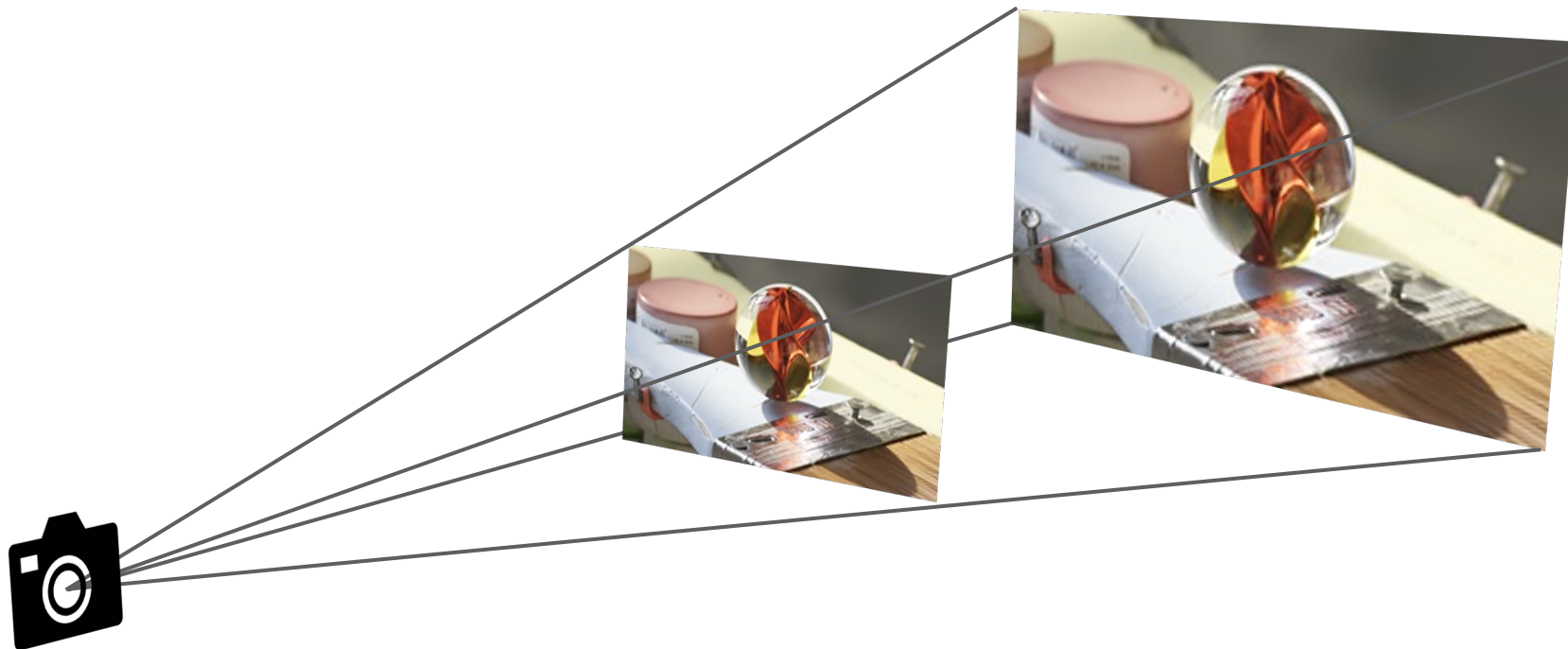

BRIGHTNESS

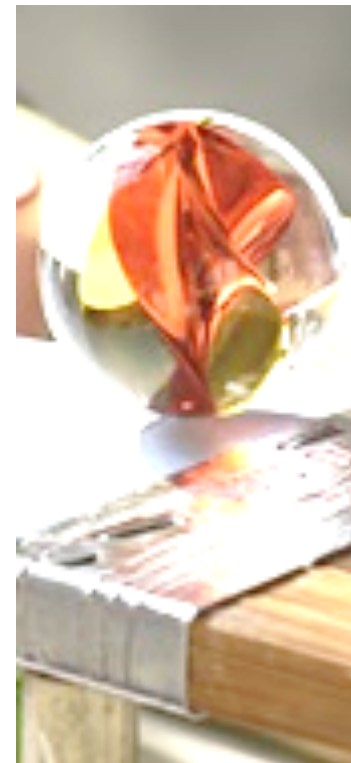
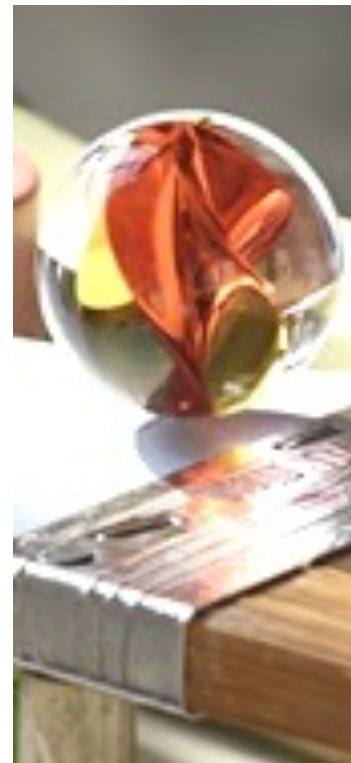
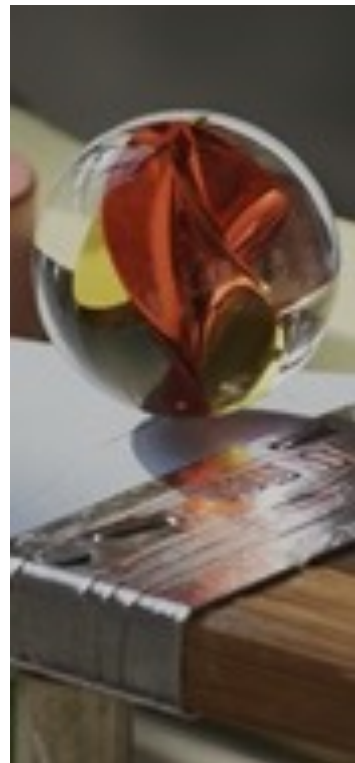
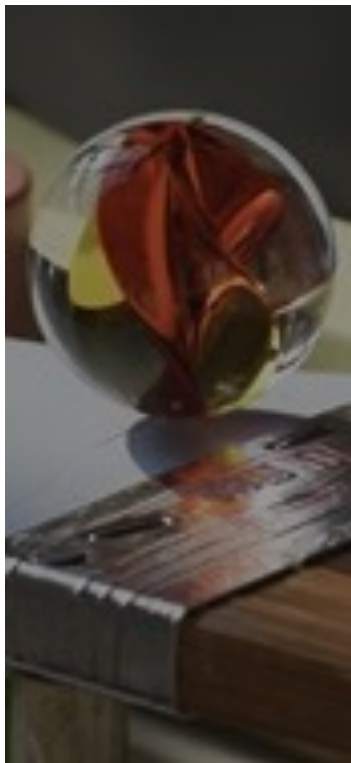

CHANNEL SHIFTING





MODEL DEPLOYMENT

MODEL DEPLOYMENT

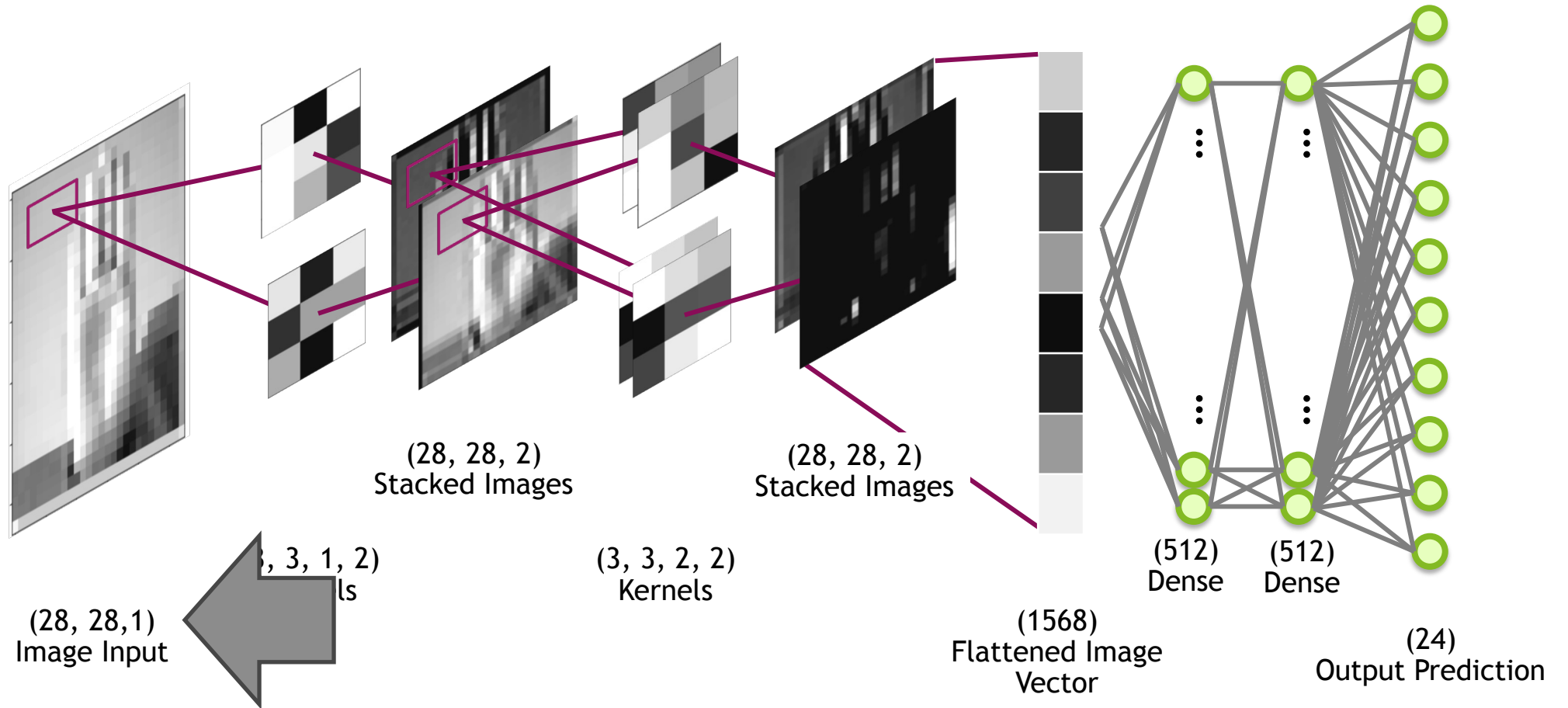

MODEL DEPLOYMENT

Training
Batch Input



Convolution

Max Pooling

...

MODEL DEPLOYMENT



(287, 433, 3)

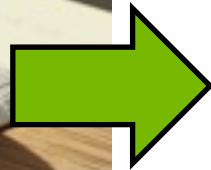

(220, 155, 3)



(220, 155, 1)

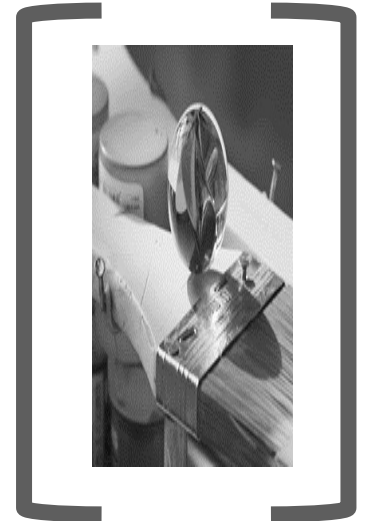

(1, 220, 155, 1)

Resize

Greyscale

“Batch”



LET'S TRY IT OUT!

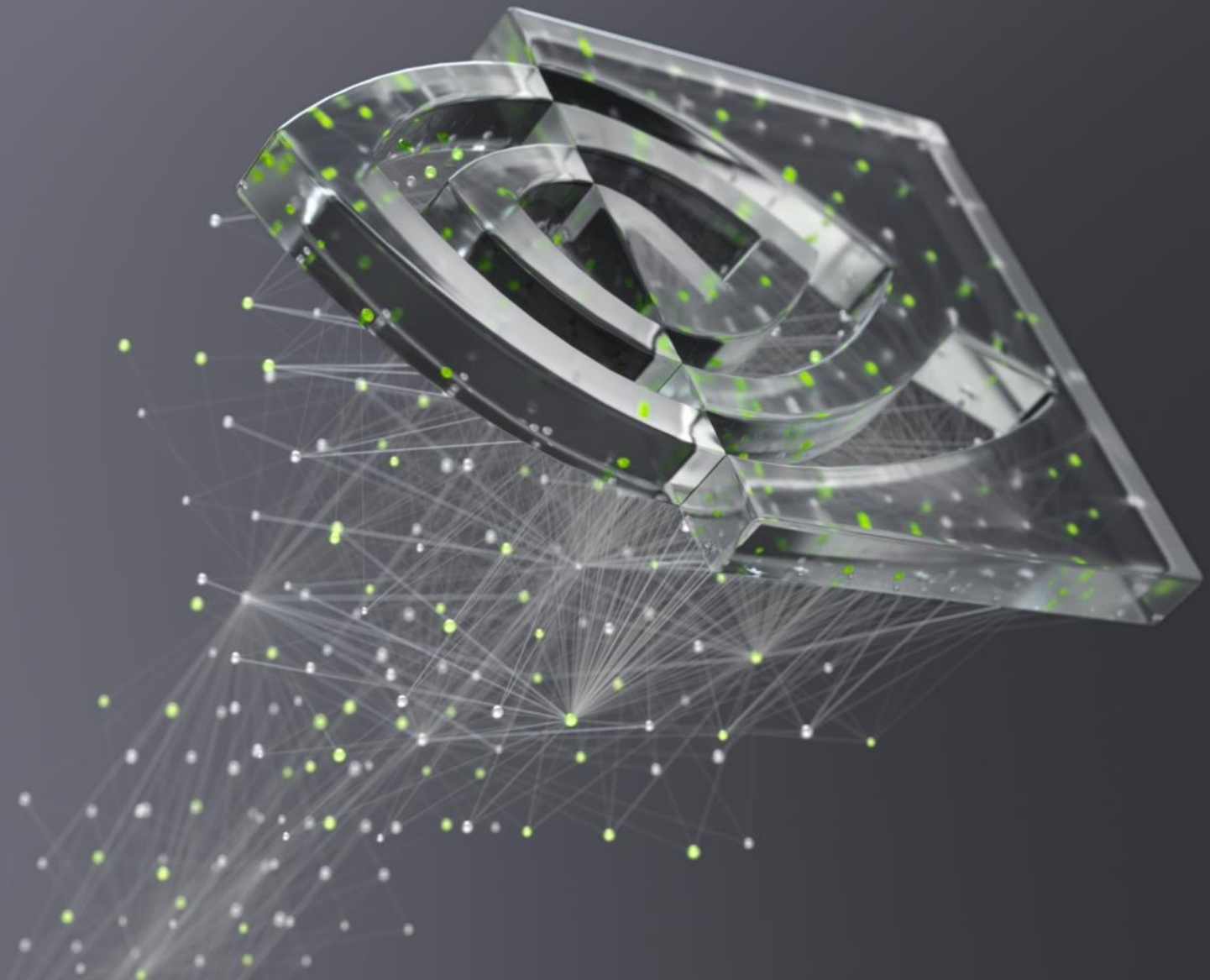

DEEP
LEARNING
INSTITUTE



DEEP
LEARNING
INSTITUTE

FUNDAMENTALS OF DEEP LEARNING

Part 5: Pre-trained Models

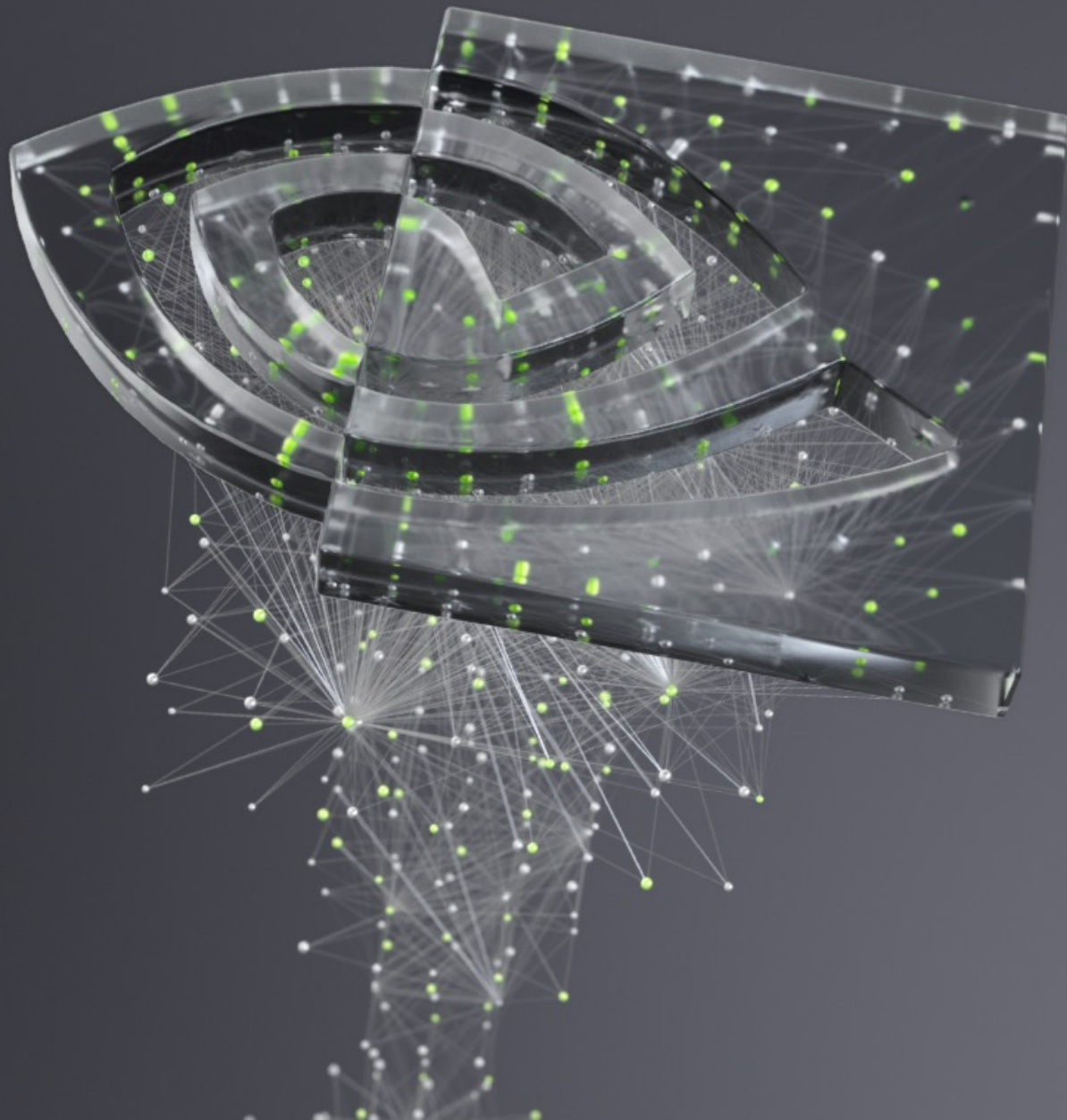

Part 1: An Introduction to Deep Learning

Part 2: How a Neural Network Trains

Part 3: Convolutional Neural Networks

Part 4: Data Augmentation and Deployment

Part 5: Pre-trained Models

Part 6: Advanced Architectures

-
-
-

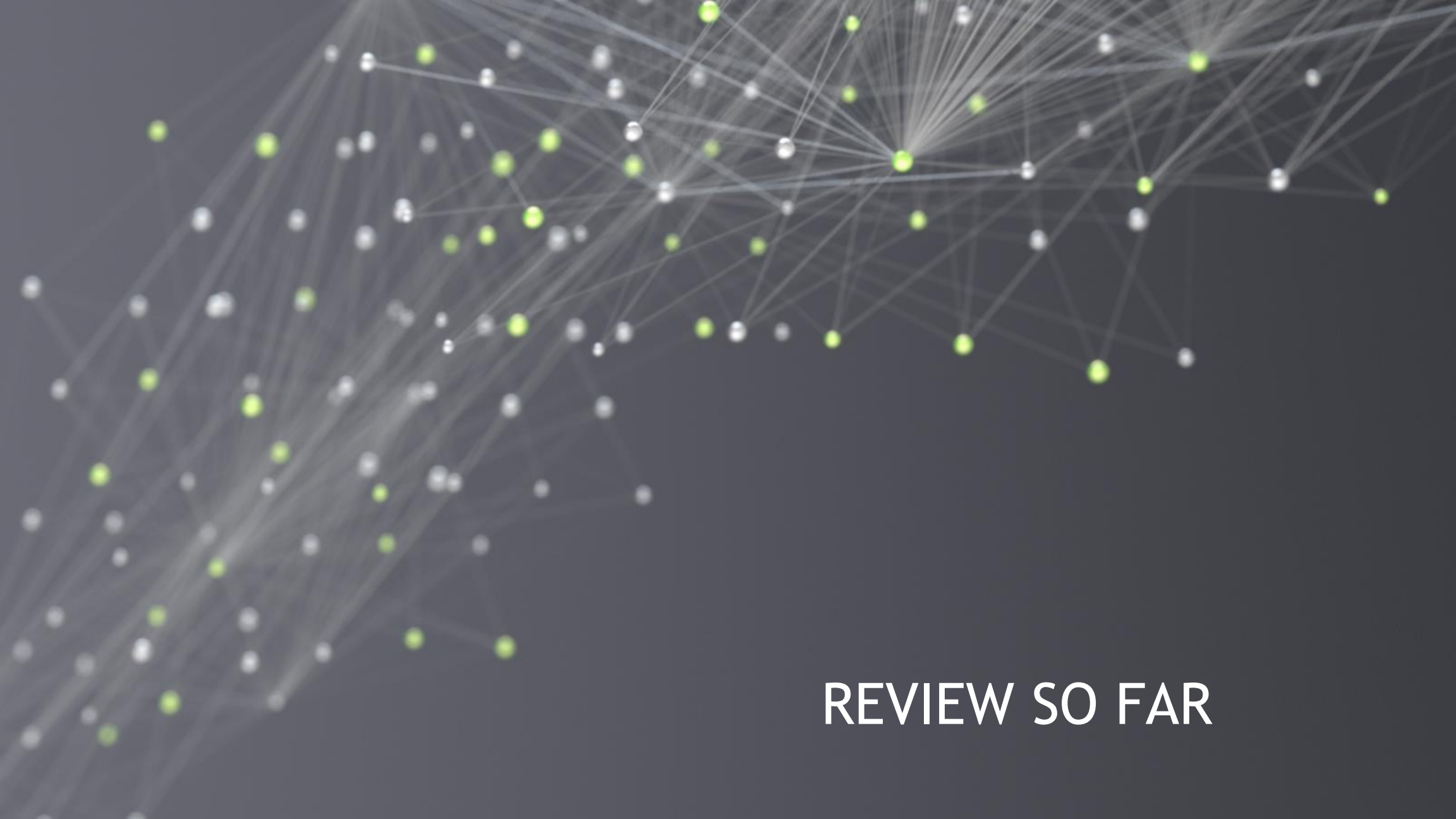

REVIEW SO FAR

REVIEW SO FAR



- Learning Rate
- Number of Layers
- Neurons per Layer
- Activation Functions
- Dropout
- Data



PRE-TRAINED MODELS

PRE-TRAINED MODELS

TensorFlow Hub

 Keras



PYTORCH
HUB

PRE-TRAINED MODELS

VERY DEEP CONVOLUTIONAL NETWORKS FOR LARGE-SCALE IMAGE RECOGNITION

Karen Simonyan* & Andrew Zisserman⁺

Visual Geometry Group, Department of Engineering Science, University of Oxford
{karen, az}@robots.ox.ac.uk

IM  GENET

THE NEXT CHALLENGE

An Automated Doggy Door





TRANSFER LEARNING

THE CHALLENGE AFTER An Automated Doggy Door



TRANSFER LEARNING



TRANSFER LEARNING

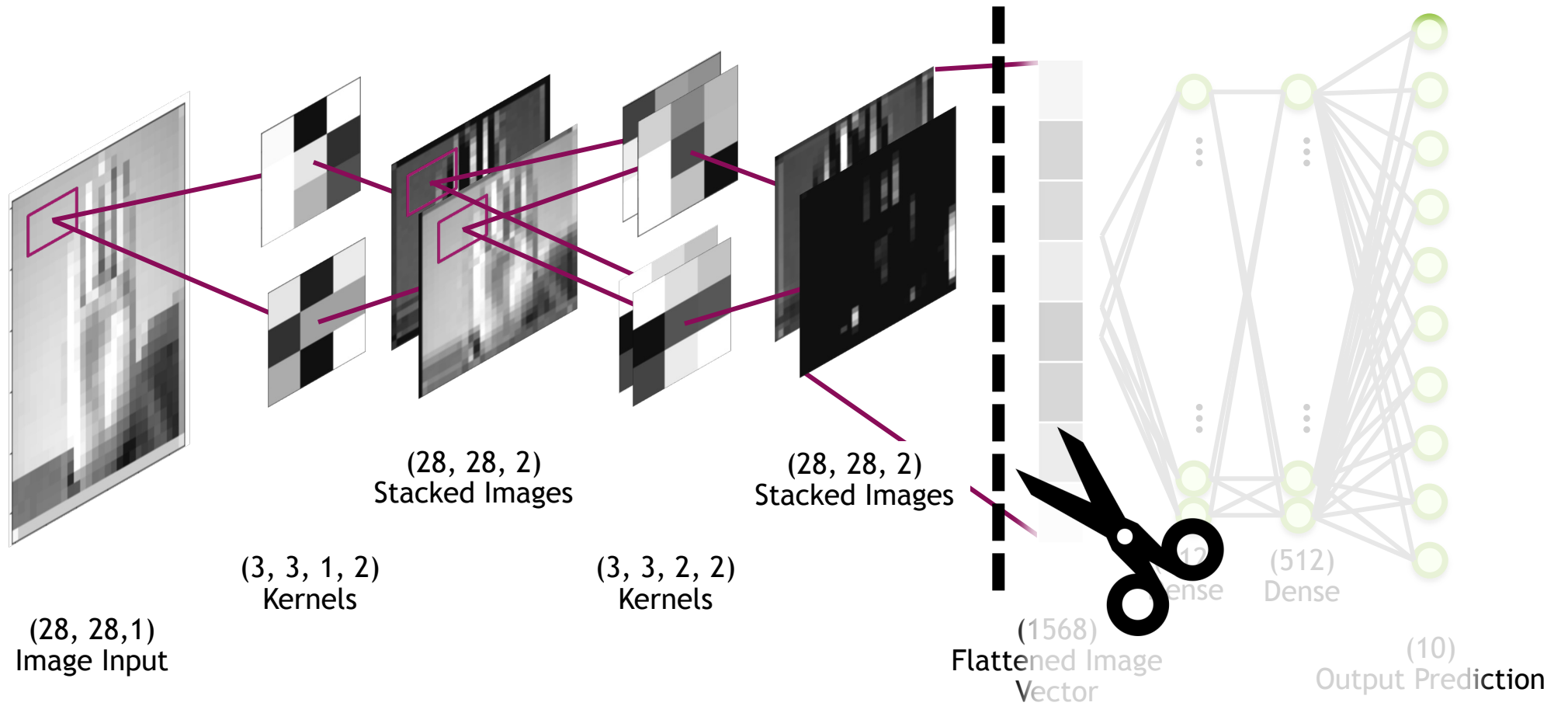

TRANSFER LEARNING

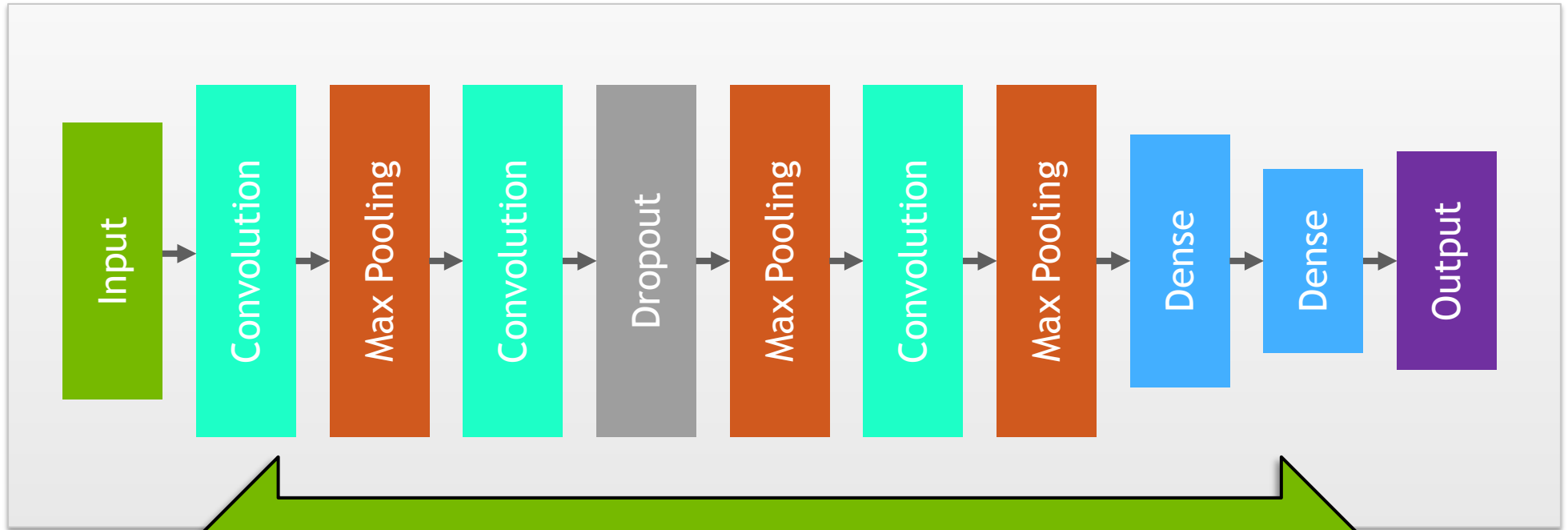

More Generalized

More Specialized

TRANSFER LEARNING

Freezing the Model?



TRANSFER LEARNING

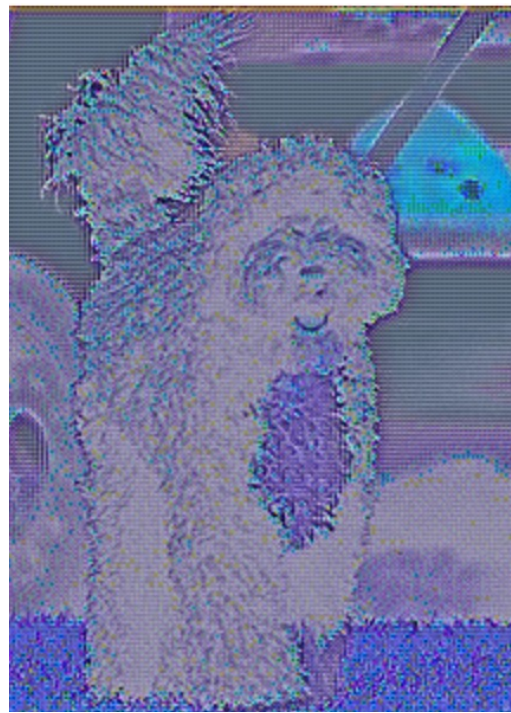
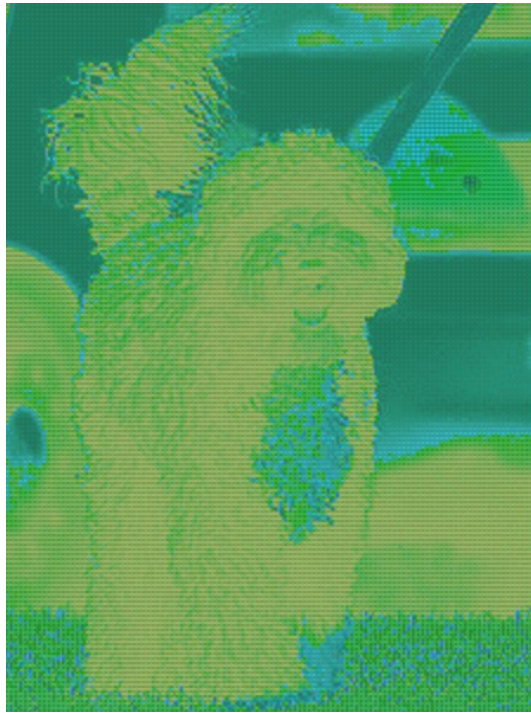



LET'S GET STARTED!

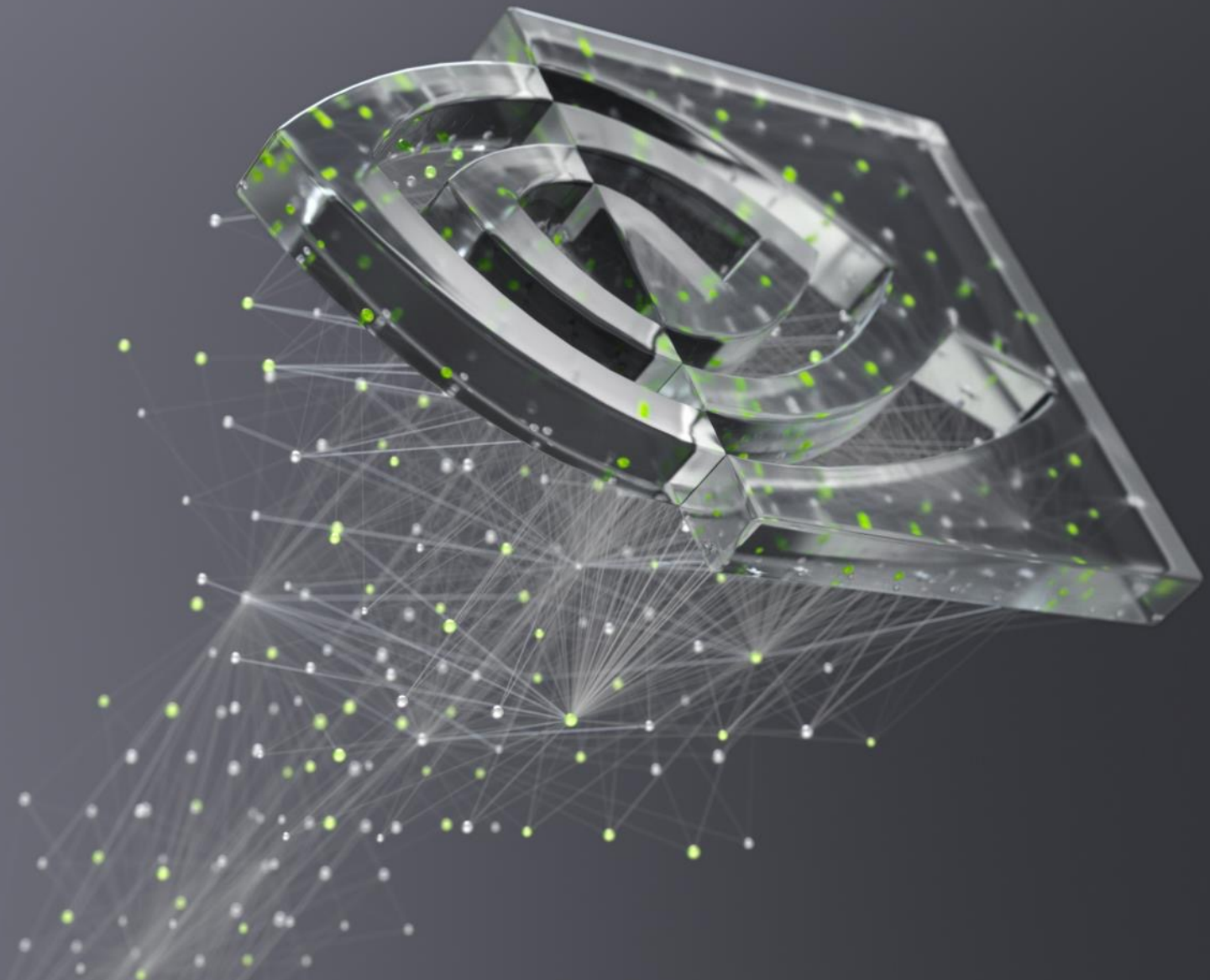

DEEP
LEARNING
INSTITUTE



DEEP
LEARNING
INSTITUTE

FUNDAMENTALS OF DEEP LEARNING

Part 6: Advanced Architectures

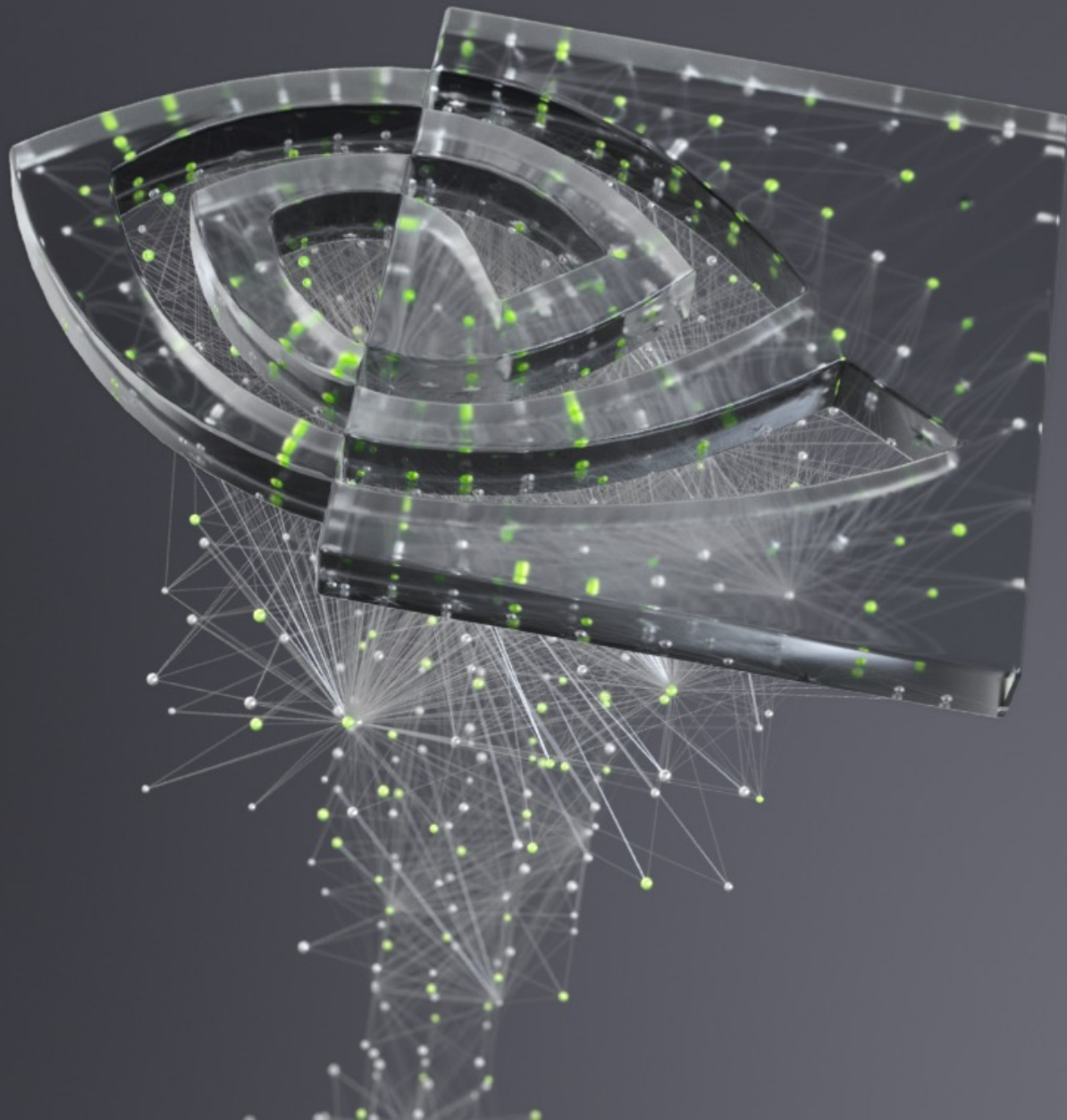

Part 1: An Introduction to Deep Learning

Part 2: How a Neural Network Trains

Part 3: Convolutional Neural Networks

Part 4: Data Augmentation and Deployment

Part 5: Pre-trained Models

Part 6: Advanced Architectures

•

•

•

•

•



MOVING FORWARD

FIELDS OF AI



Computer Vision

- Optometry



Natural Language Processing

- Linguistics

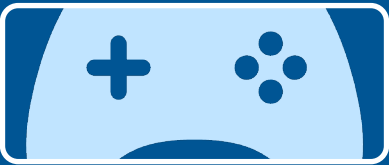

Reinforcement Learning

- Game Theory
- Psychology



Anomaly Detection

- Security
- Medicine

FIELDS OF AI



Computer Vision

- Optometry



Natural Language Processing

- Linguistics



Reinforcement Learning

- Game Theory
- Psychology



Anomaly Detection

- Security
- Medicine

FIELDS OF AI



Computer Vision

- Optometry

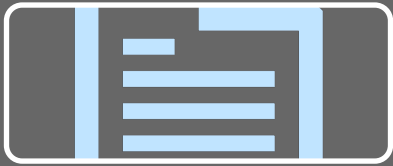

Natural Language Processing

- Linguistics

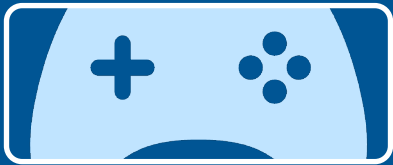

Reinforcement Learning

- Game Theory
- Psychology



Anomaly Detection

- Security
- Medicine



NATURAL LANGUAGE PROCESSING

FROM WORDS TO NUMBERS

“A dog barked at a cat.”

[1, 10, 7, 4, 1, 8]

Dictionary

- | | |
|-----------|----------|
| 1. A | 8. Cat |
| 2. An | 9. Cats |
| 3. And | 10. Dog |
| 4. At | 11. Dogs |
| 5. Ate | 12. Eat |
| 6. Bark | |
| 7. Barked | |

FROM WORDS TO NUMBERS

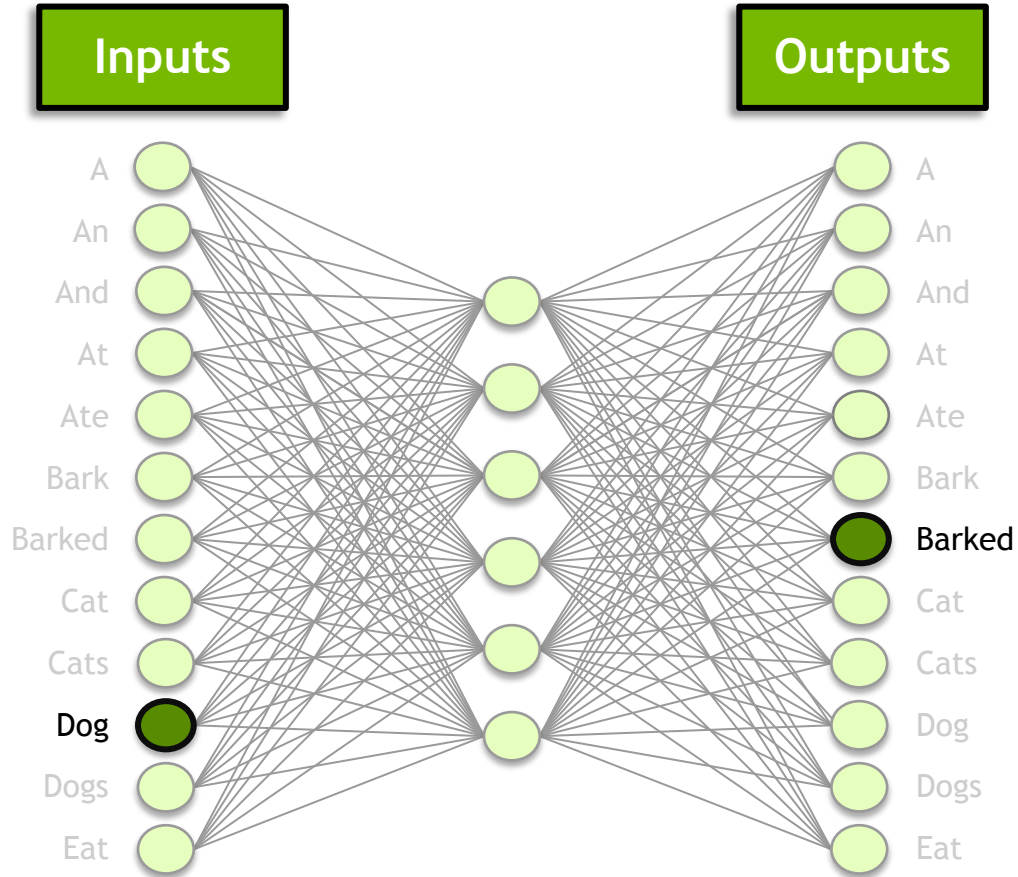

FROM WORDS TO NUMBERS

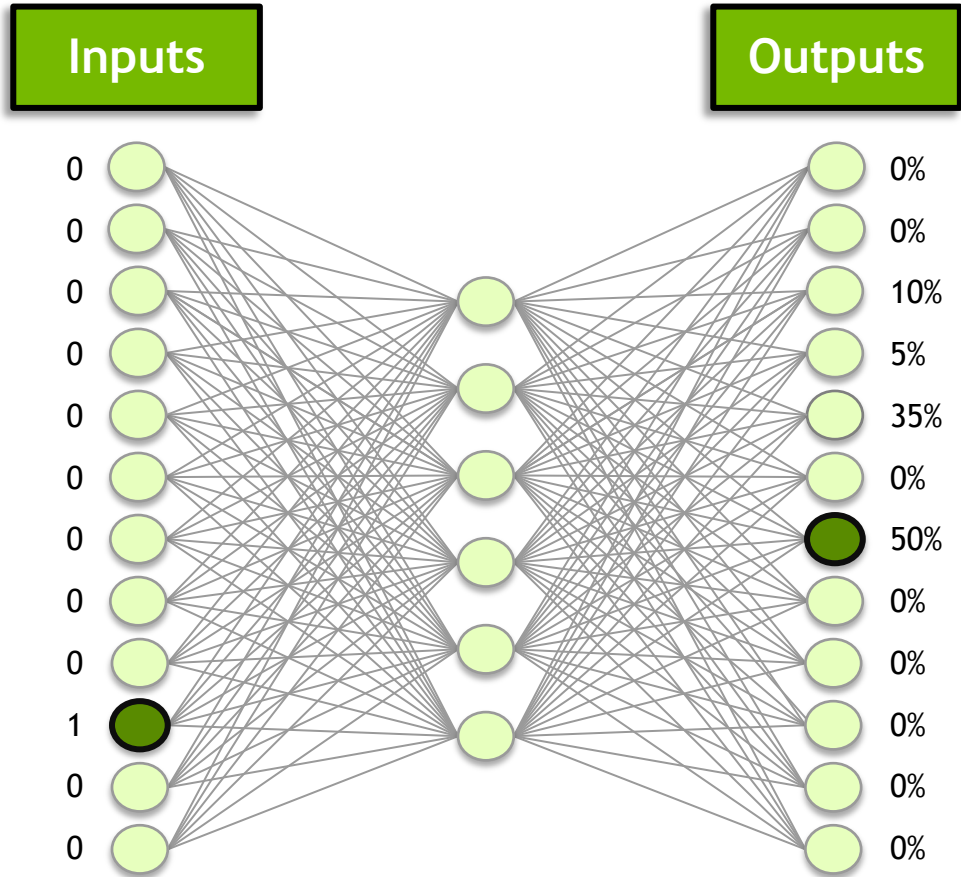

Dictionary

1. A	8. Cat
2. An	9. Cats
3. And	10. Dog
4. At	11. Dogs
5. Ate	12. Eat
6. Bark	
7. Barked	

FROM WORDS TO NUMBERS

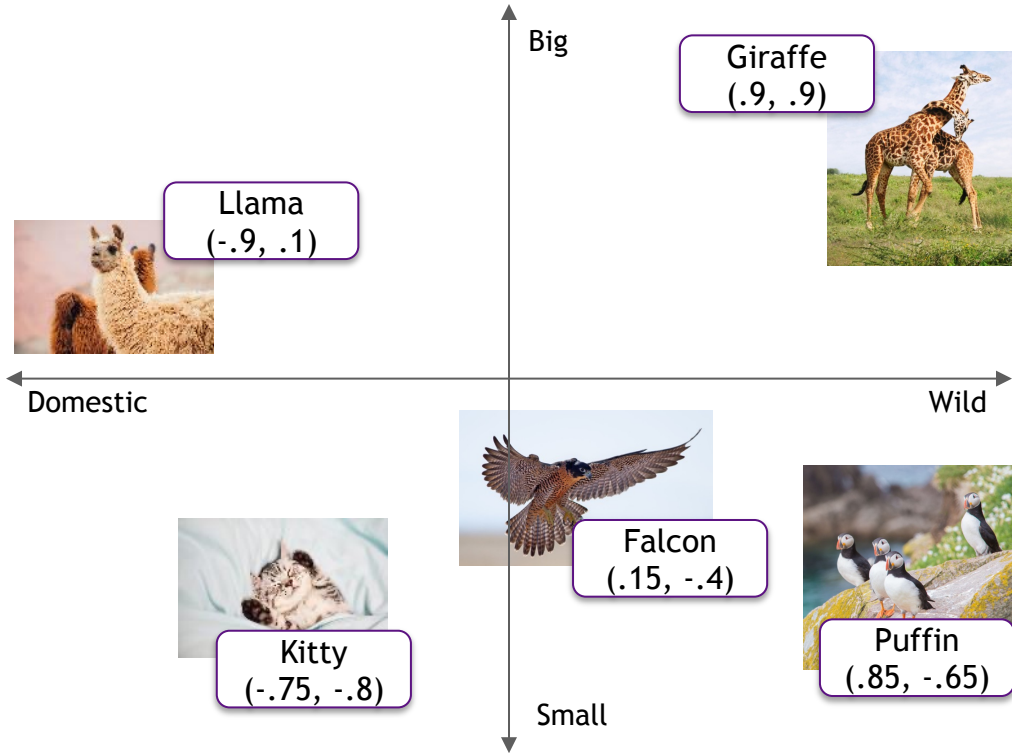

Bigger Dictionary

1.	A	31.	Ate	61.	Cats
2.	An	32.	Bark	62.	Dog
3.	And	33.	Barked	63.	Dogs
4.	At	34.	Cat	64.	Eat
5.	Ate	35.	Cats	65.	Eaten
6.	Bark	36.	Dog	66.	A
7.	Barked	37.	Dogs	67.	An
8.	Cat	38.	Eat	68.	And
9.	Cats	39.	Eaten	69.	At
10.	Dog	40.	A	70.	Ate
11.	Dogs	41.	An	71.	Bark
12.	Eat	42.	And	72.	Barked
13.	Eaten	43.	At	73.	Cat
14.	A	44.	Ate	74.	Cats
15.	An	45.	Bark	75.	Dog
16.	And	46.	Barked	76.	Dogs
17.	At	47.	Cat	77.	Eat
18.	Ate	48.	Cats	78.	Eaten
19.	Bark	49.	Dog	79.	...
20.	Barked	50.	Dogs	80.	...
21.	Cat	51.	Eat	81.	...
22.	Cats	52.	Eaten	82.	...
23.	Dog	53.	A		
24.	Dogs	54.	An		
25.	Eat	55.	And		
26.	Eaten	56.	At		
27.	A	57.	Ate		
28.	An	58.	Bark		
29.	And	59.	Barked		
30.	At	60.	Cat		

FROM WORDS TO NUMBERS

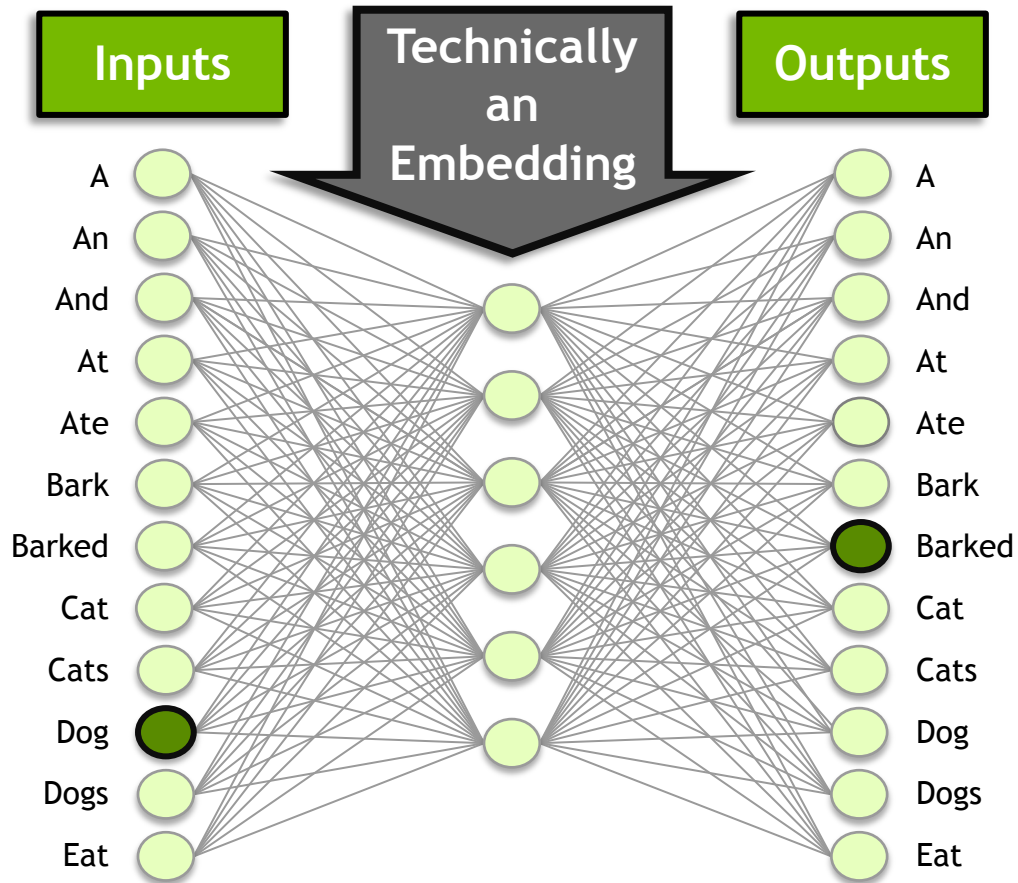

Dictionary

1. A	8. Cat
2. An	9. Cats
3. And	10. Dog
4. At	11. Dogs
5. Ate	12. Eat
6. Bark	
7. Barked	



RECURRENT NEURAL NETWORKS

RECURRENT NEURAL NETWORKS

“Cats say ____.”

“Dogs say ____.”

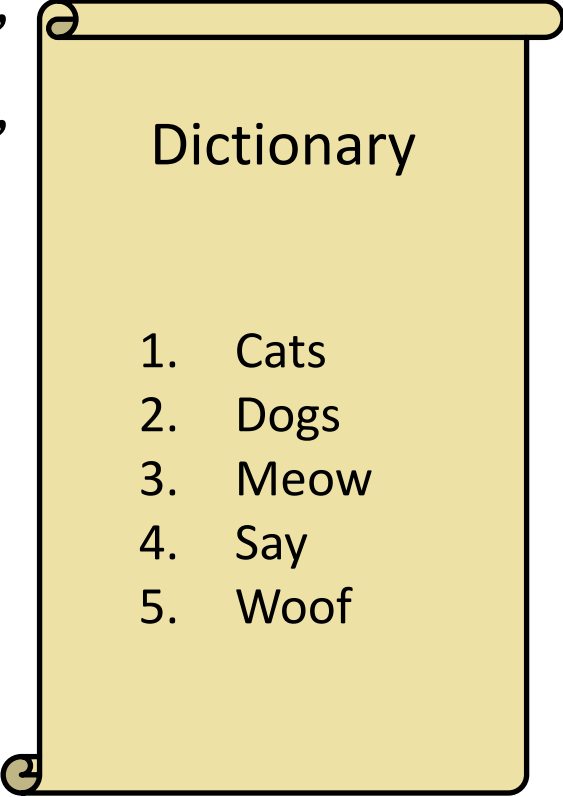

Dictionary

1. Cats
2. Dogs
3. Meow
4. Say
5. Woof

RECURRENT NEURAL NETWORKS

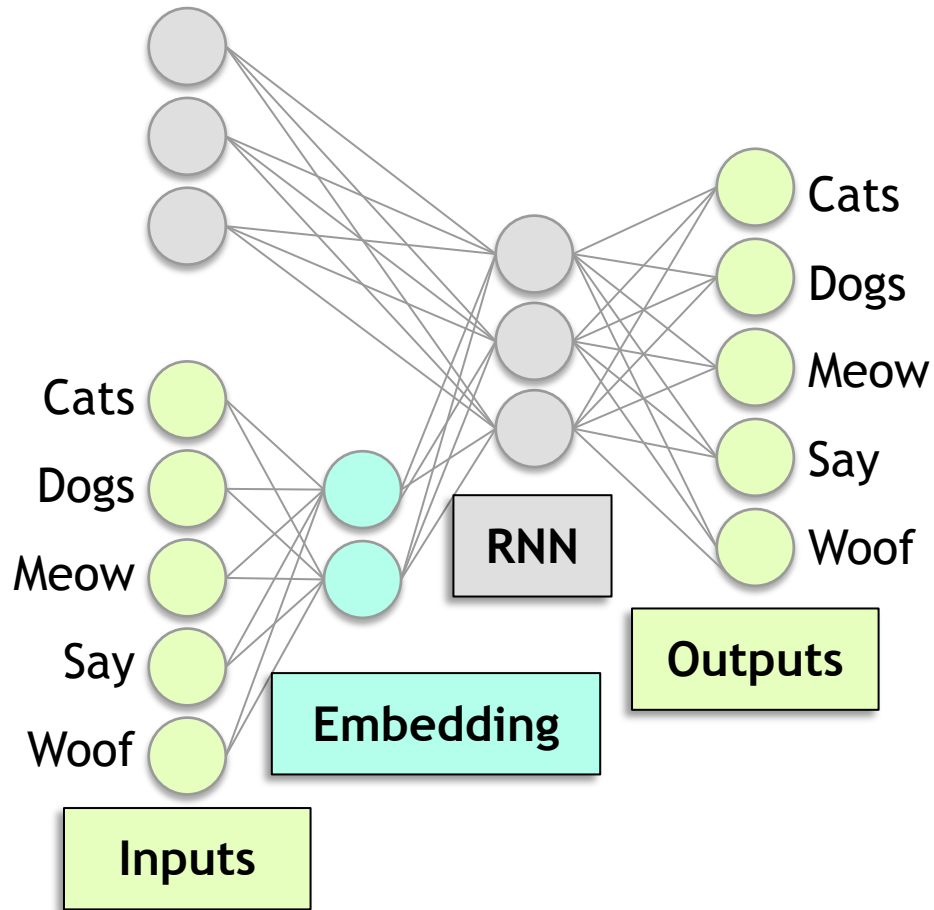

“Cats say ____.”

“Dogs say ____.”

Dictionary

1. Cats
2. Dogs
3. Meow
4. Say
5. Woof

RECURRENT NEURAL NETWORKS

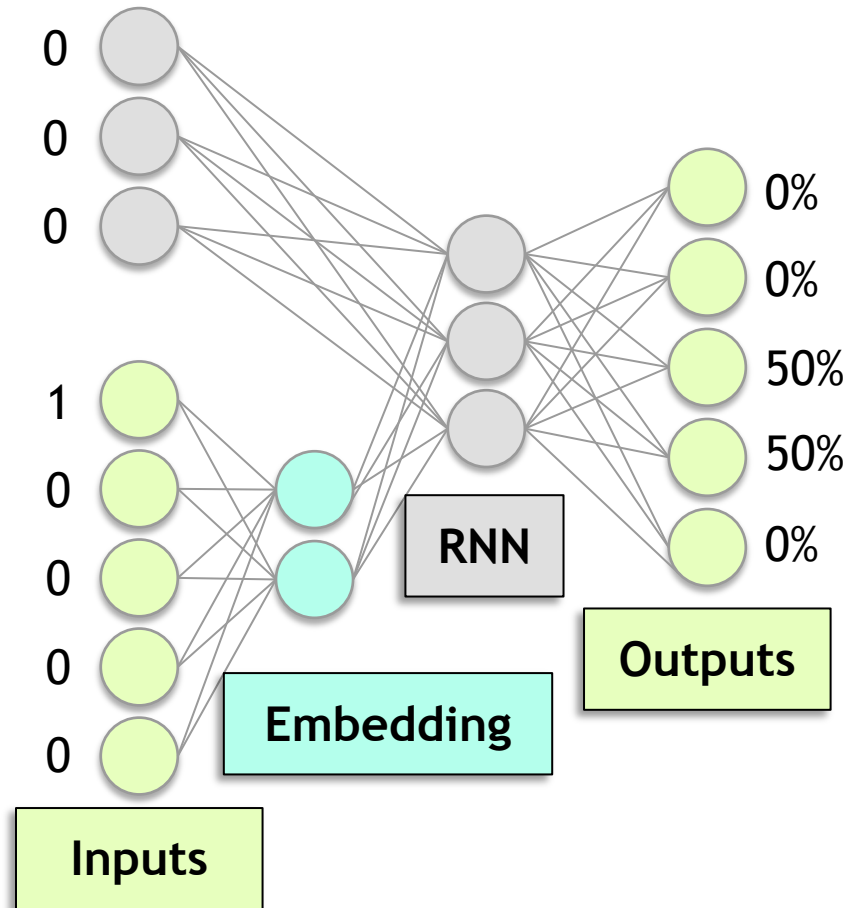

“Cats say ____.”

“Dogs say ____.”

Dictionary

1. Cats
2. Dogs
3. Meow
4. Say
5. Woof

RECURRENT NEURAL NETWORKS

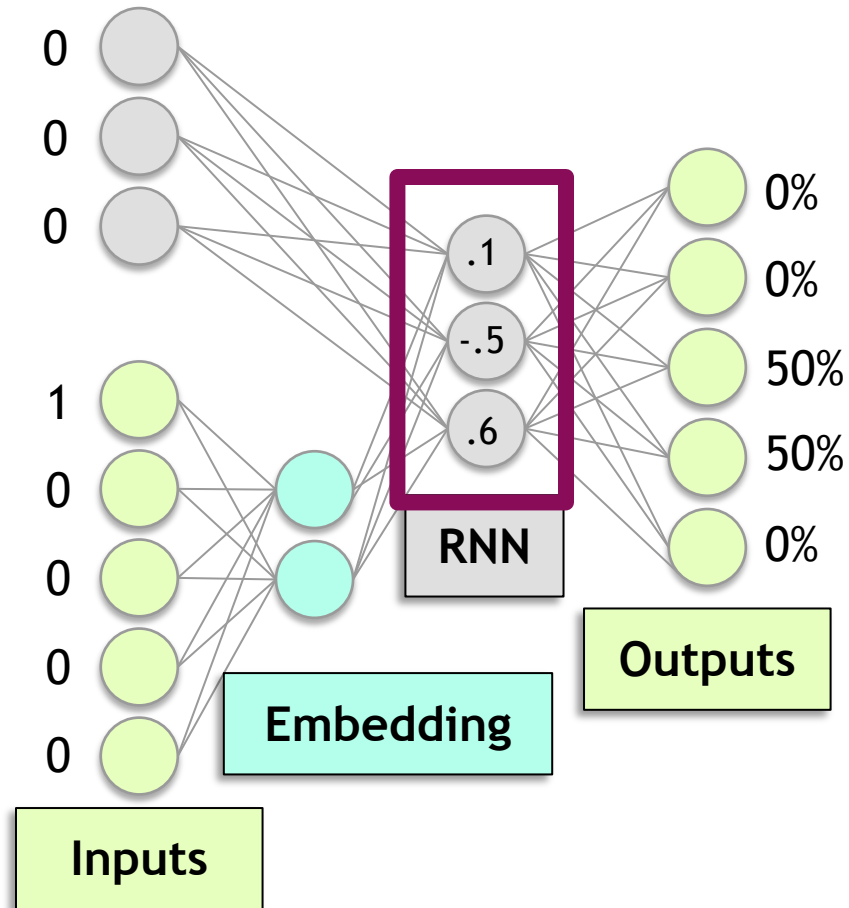

“Cats say ____.”

“Dogs say ____.”

Dictionary

1. Cats
2. Dogs
3. Meow
4. Say
5. Woof

RECURRENT NEURAL NETWORKS

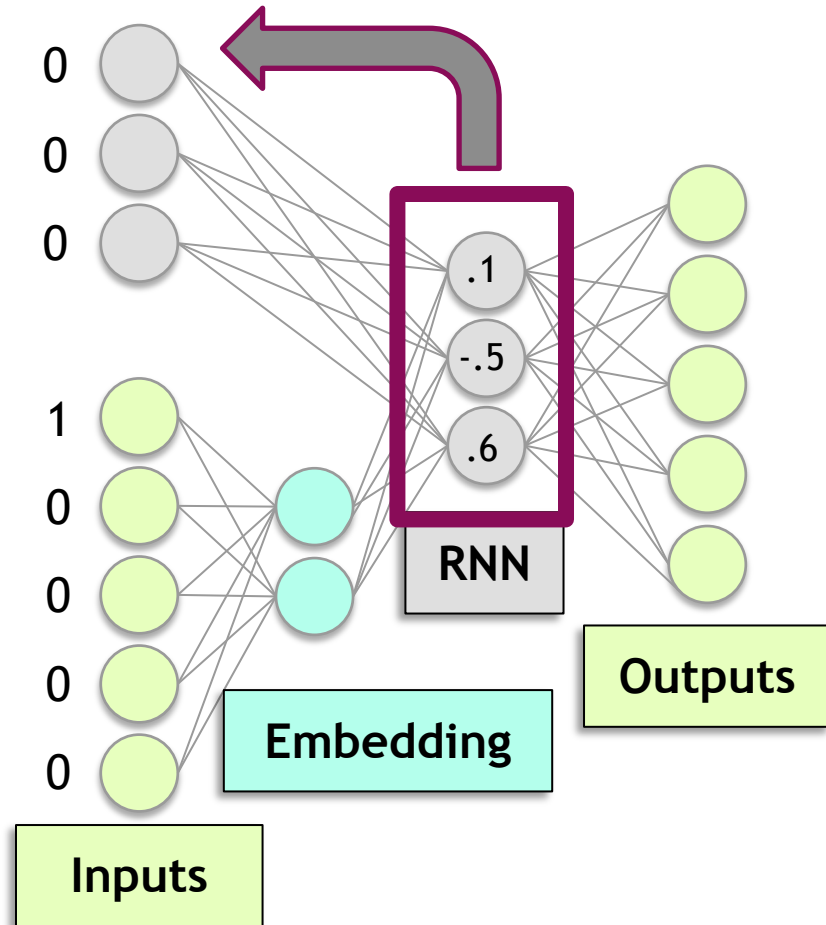

“Cats say ____.”

“Dogs say ____.”

Dictionary

1. Cats
2. Dogs
3. Meow
4. Say
5. Woof

RECURRENT NEURAL NETWORKS

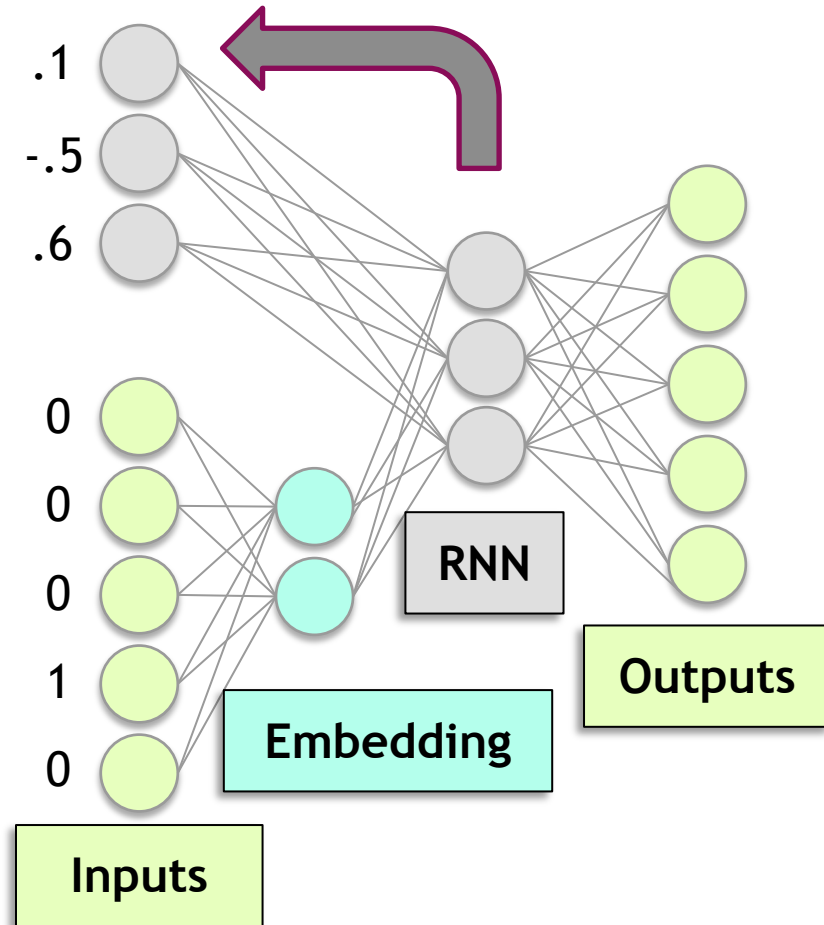

“Cats say ____.”

“Dogs say ____.”

Dictionary

1. Cats
2. Dogs
3. Meow
4. Say
5. Woof

RECURRENT NEURAL NETWORKS

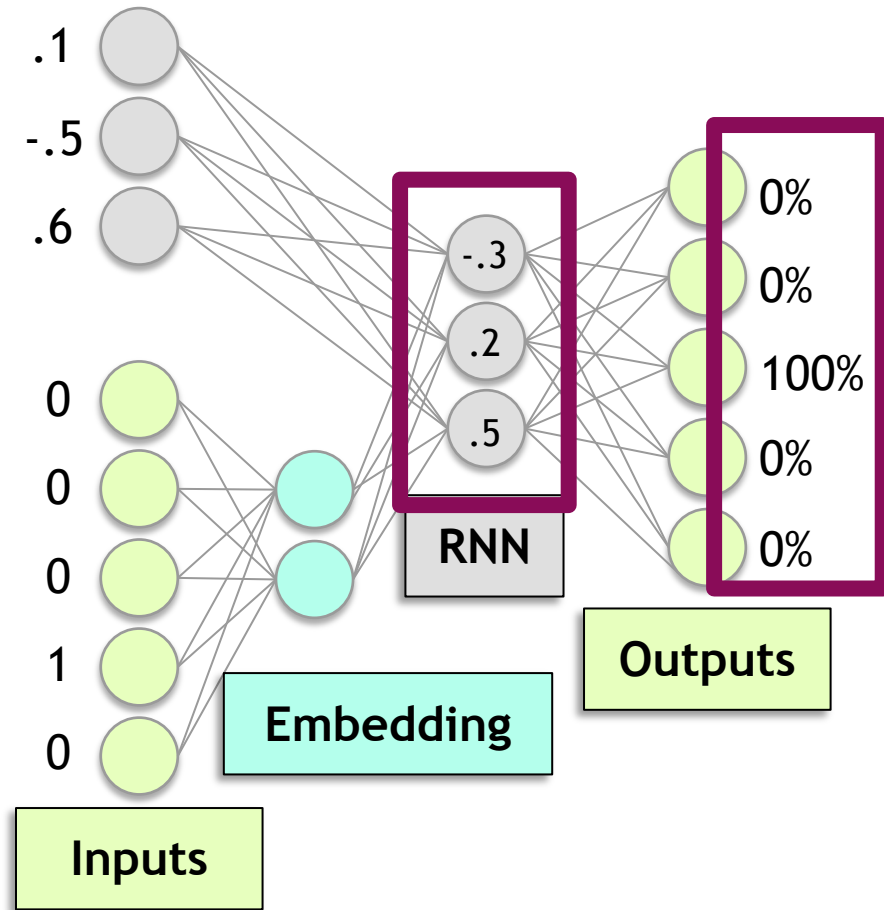

“Cats say ____.”

“Dogs say ____.”

Dictionary

1. Cats
2. Dogs
3. Meow
4. Say
5. Woof

RECURRENT NEURAL NETWORKS

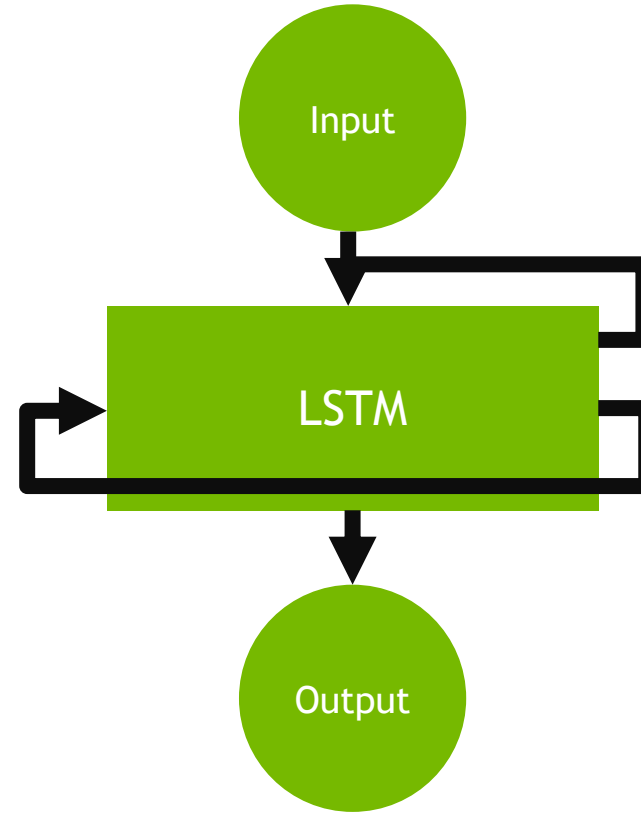
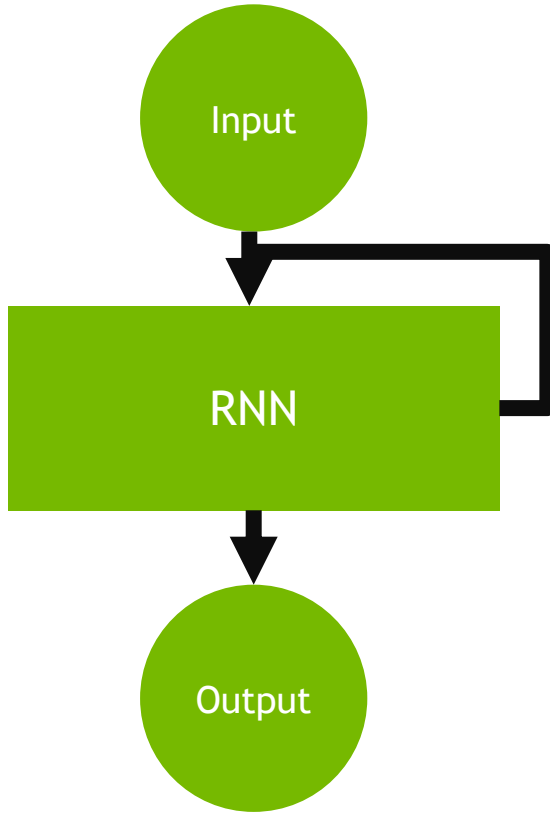



OTHER ARCHITECTURES

AUTOENCODERS

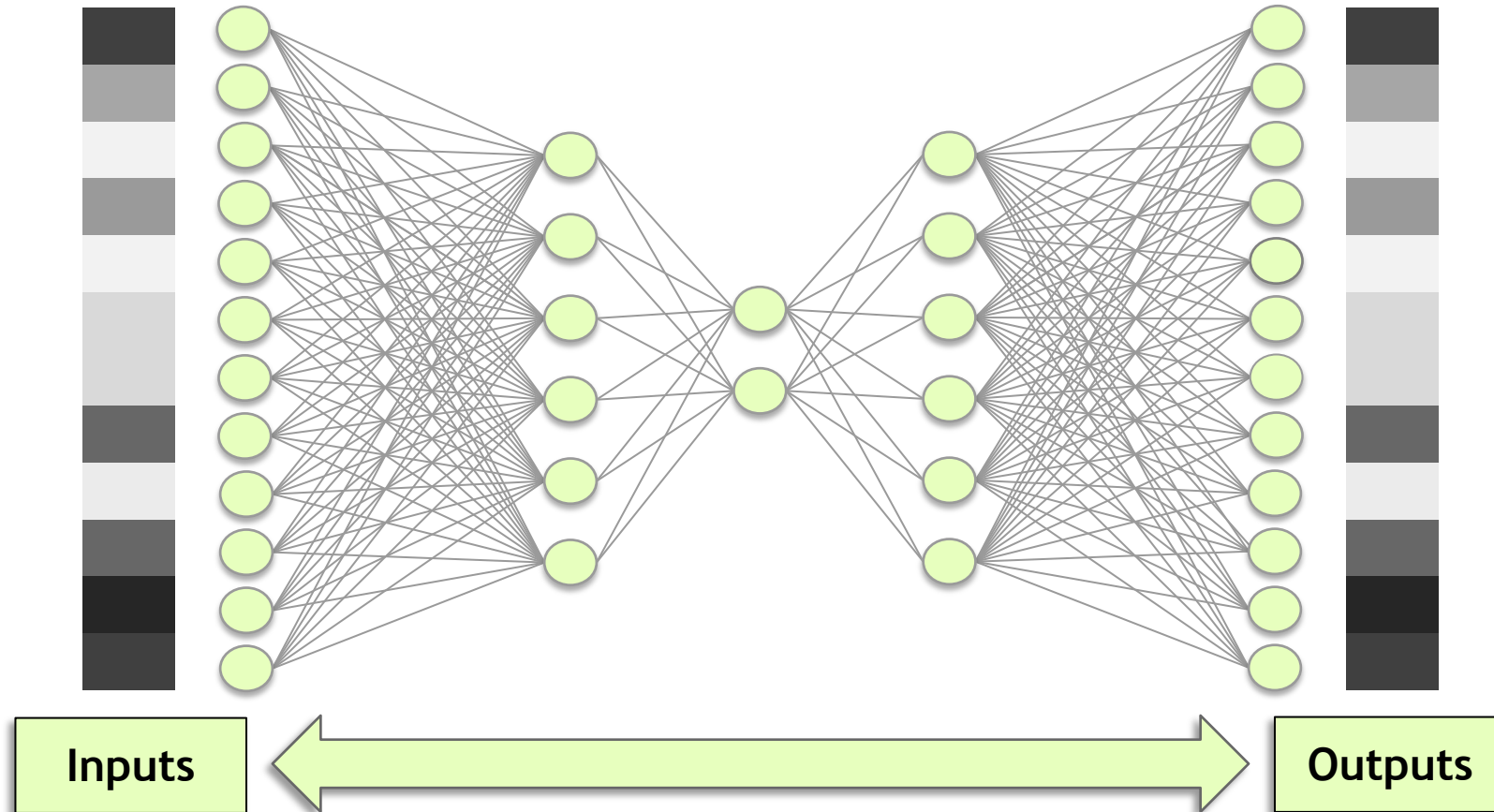

AUTOENCODERS

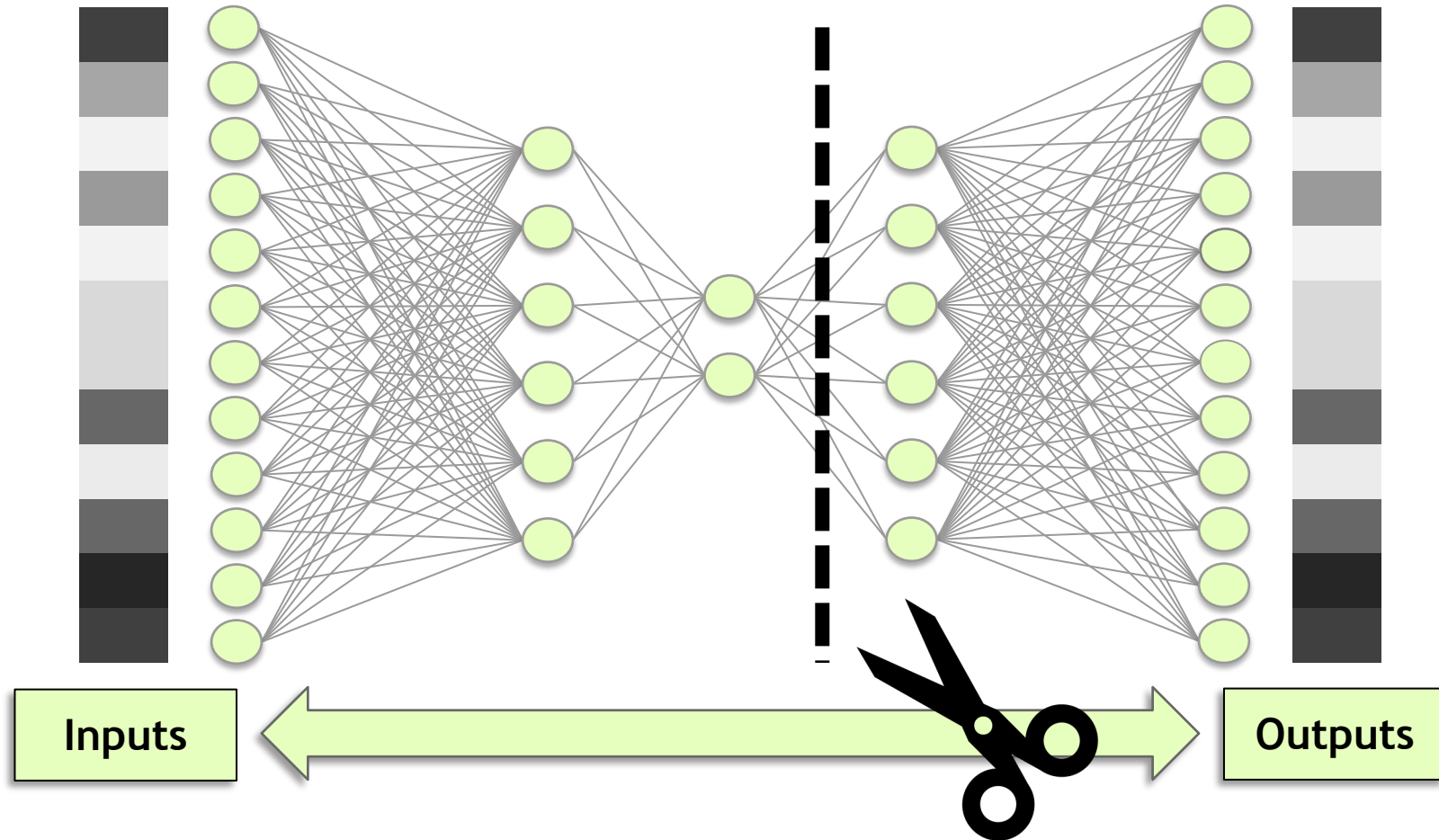

AUTOENCODERS

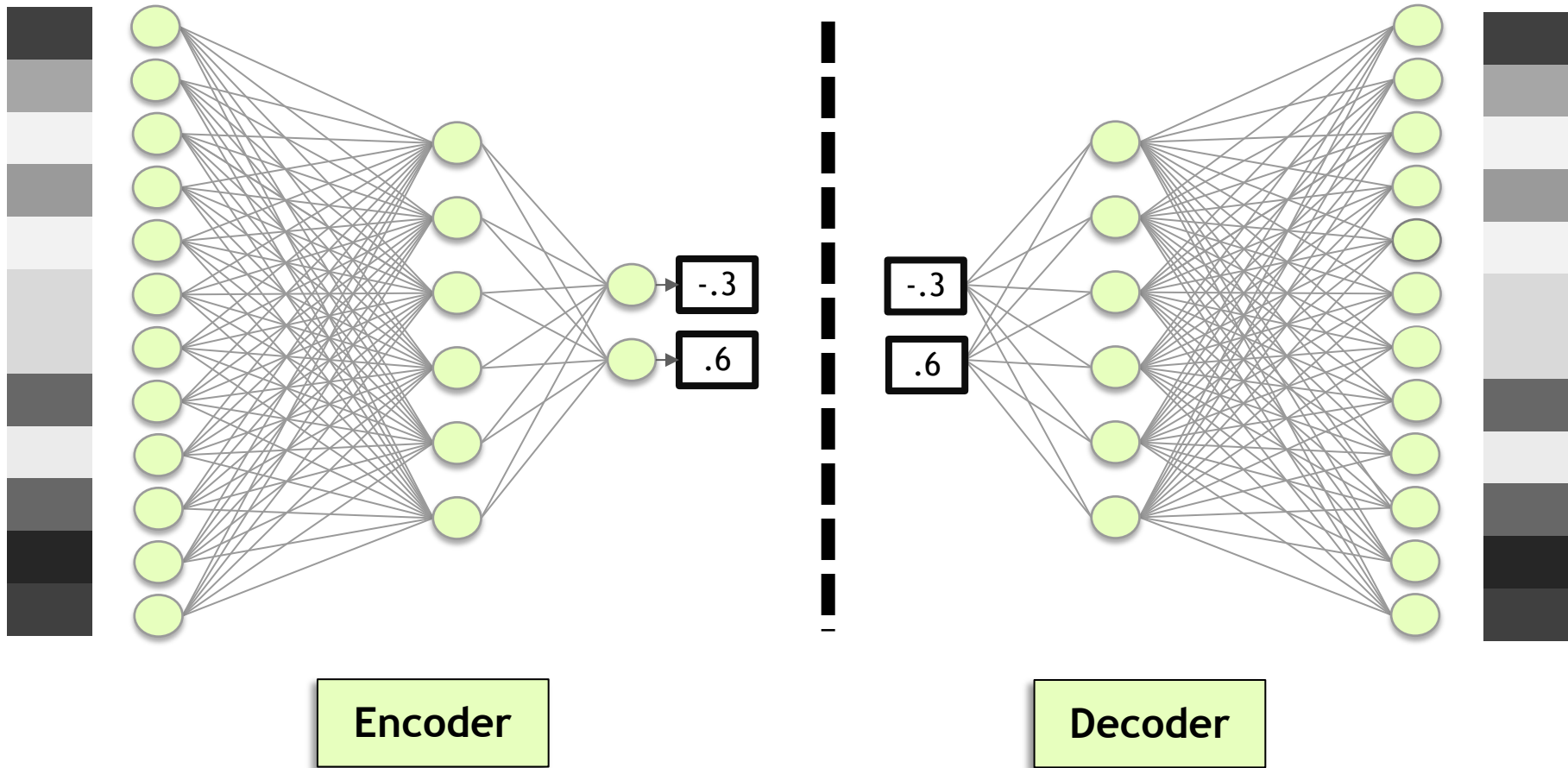

GENERATIVE ADVERSARIAL NETWORKS (GANS)

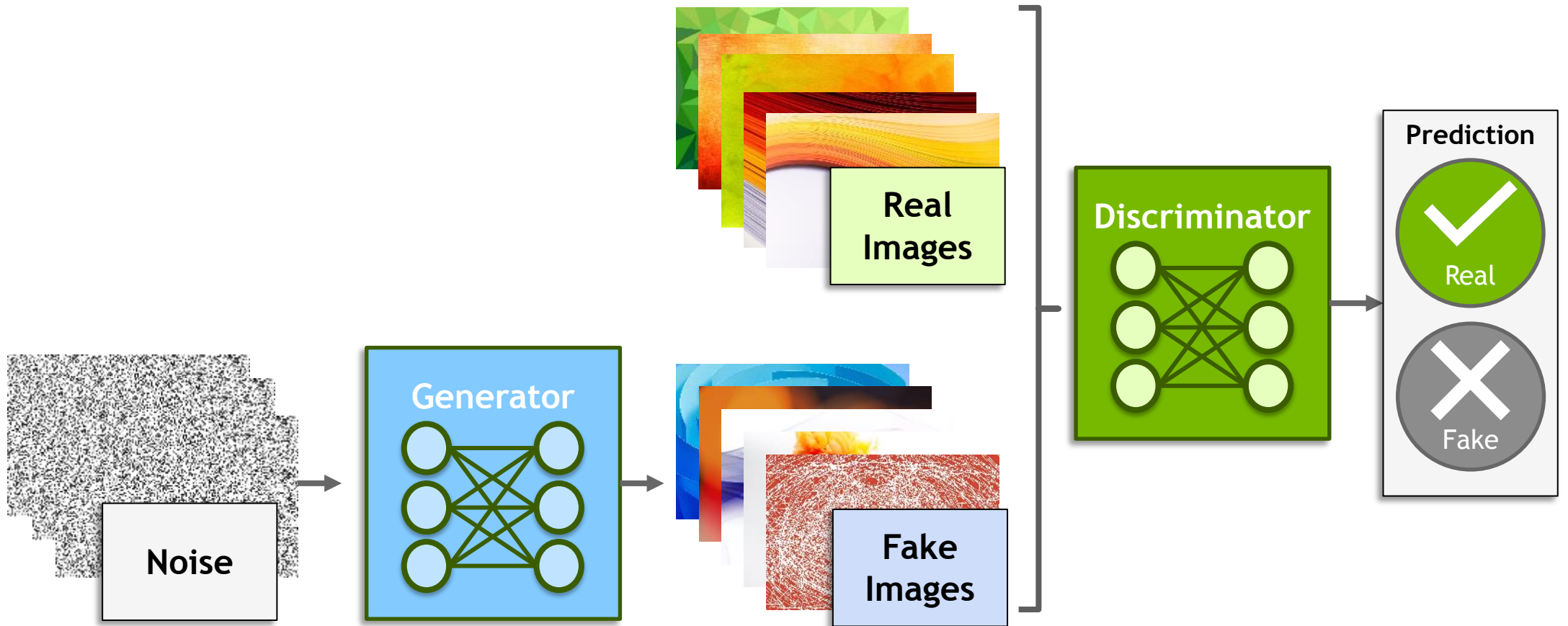

REINFORCEMENT LEARNING

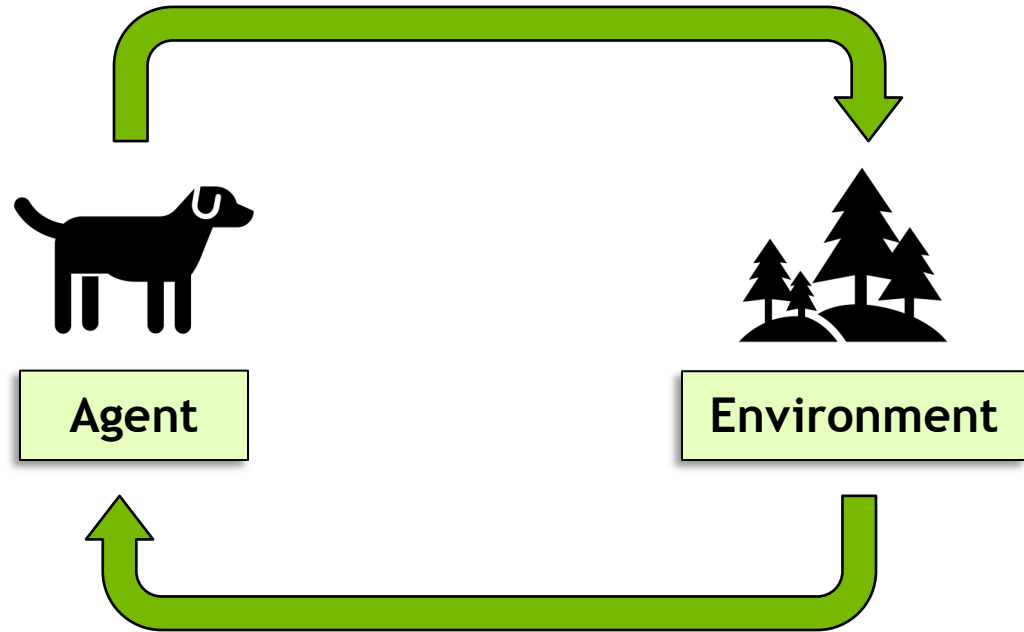



NEXT STEPS

ENABLING PORTABILITY WITH NGC CONTAINERS

Extensive

- Diverse range of workloads and industry specific use cases

Optimized

- DL containers updated monthly
- Packed with latest features and superior performance

Secure & Reliable

- Scanned for vulnerabilities and crypto
- Tested on workstations, servers, & cloud instances

Scalable

- Supports multi-GPU & multi-node systems

Designed for Enterprise & HPC

- Supports Docker, Singularity & other runtimes

Run Anywhere

- Bare metal, VMs, Kubernetes
- x86, ARM, POWER
- Multi-cloud, on-prem, hybrid, edge

NGC Deep Learning Containers

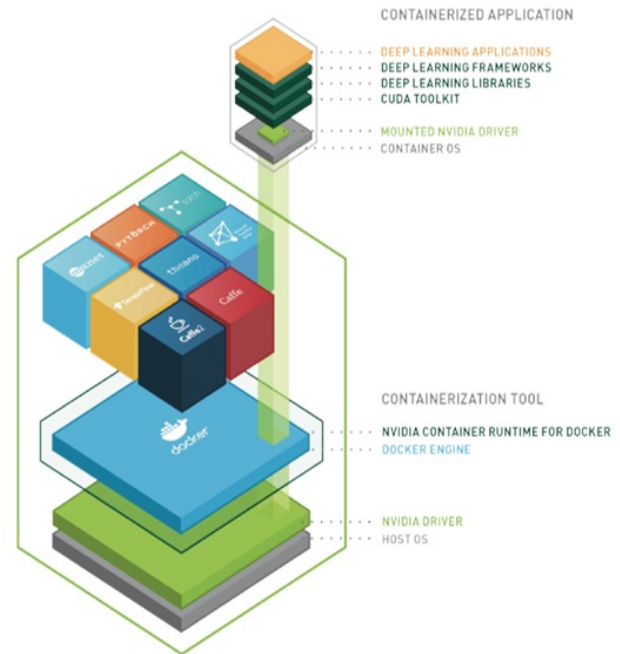

CONVERSATIONAL AI



Riva

HEALTHCARE



CLARA

SMART CITIES



DEEPSTREAM & SMART PARKING

TELECOM



AERIAL

AUTONOMOUS DRIVING



DRIVE

ROBOTICS



ISAAC

HPC



HPC SDK

[Learn more about NGC Containers](#)

NEXT STEPS FOR THIS CLASS

Catalog: Containers / Containers: nvidia:dli-dl-fundamentals

DLI Deep Learning Fundamentals Course - ...

Publisher	Built By	Latest Tag	Modified	Size
NVIDIA	NVIDIA	v0.0.1	October 27, 2020	4.19 GB

Multinode Support
No

Multi-Arch Support
✕

Description
Base environment used in the NVIDIA Deep Learning Institute (DLI) Course Fundamentals of Deep Learning, along with Next Steps project.

Labels

Computer Vision DLI Jupyter Machine Learning Machine Learning & AI

Pull Command

```
docker pull nvcr.io/nvidia/dli-dl-fundamentals:v0.0.1
```

Step 1 Sign up for NGC

<https://docs.nvidia.com/dgx/ngc-registry-for-dgx-user-guide/index.html>

Step 2 Visit NGC Catalog

<https://catalog.ngc.nvidia.com/orgs/nvidia/containers/dli-dl-fundamentals>

Step 3 Pull and Run Container

Visit localhost:8888 to check out a JupyterLab environment with a Next Steps Project



CLOSING THOUGHTS

COPYING ROCKET SCIENCE





LET'S GET STARTED!

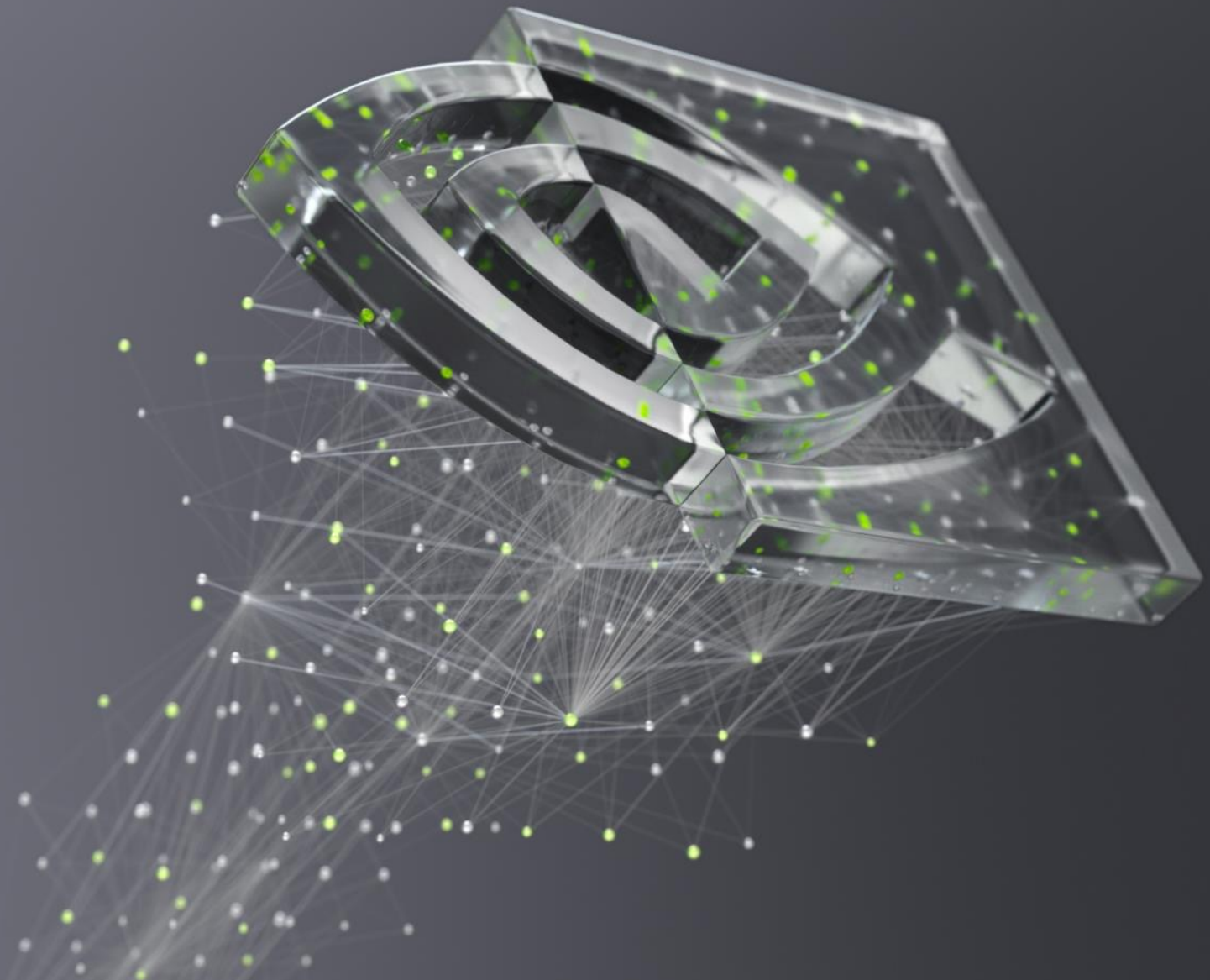

DEEP
LEARNING
INSTITUTE