

Transformation of Trace Organic Chemicals by Microbial Communities Adapted to Aniline, Histidine, or Di-sodium succinate as Carbon Source

Edwin Chingate

Technical University of Munich

School of Engineering and Design

Chair of Urban Water Systems Engineering

Munich, 14. July 2022

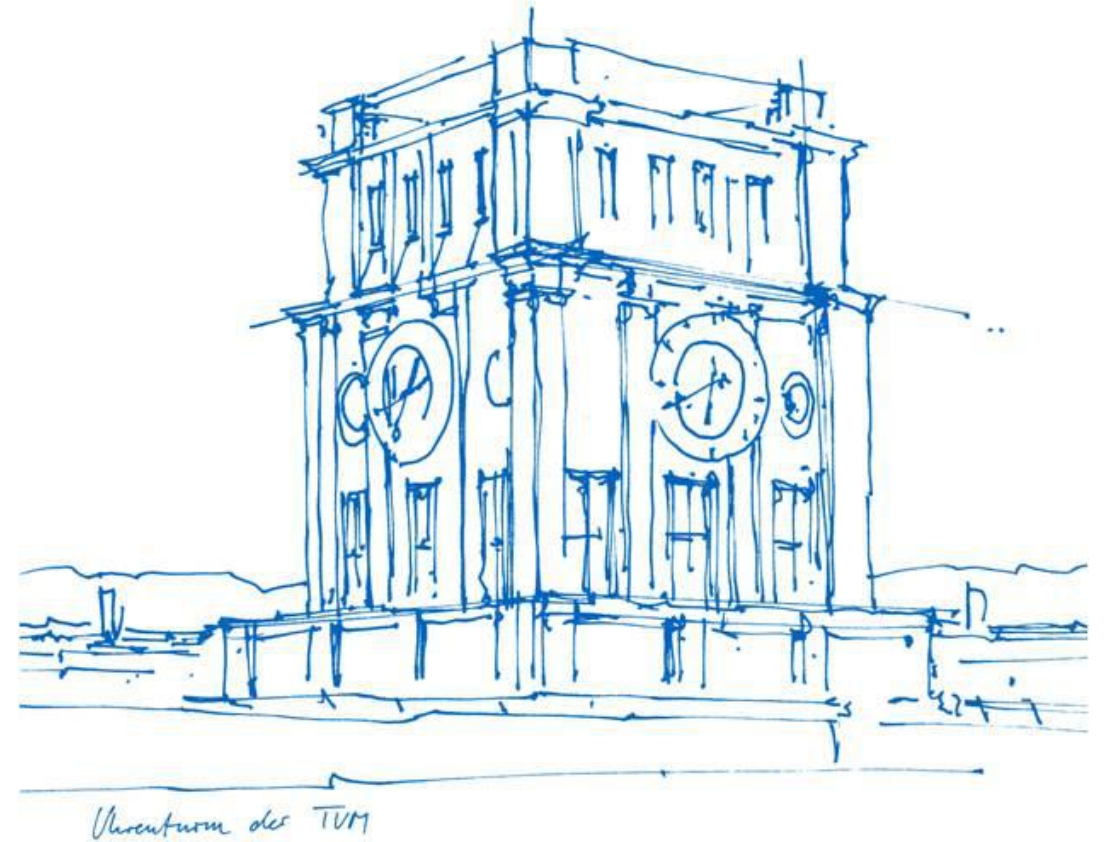

Uhrenturm der TUM

Content

- Trace organic chemicals and biological removal
- Hypothesis description
- Retentostat system for the study of bacterial metabolism
- Experimental results
- On going research



Black boxes for removal of TOrCs

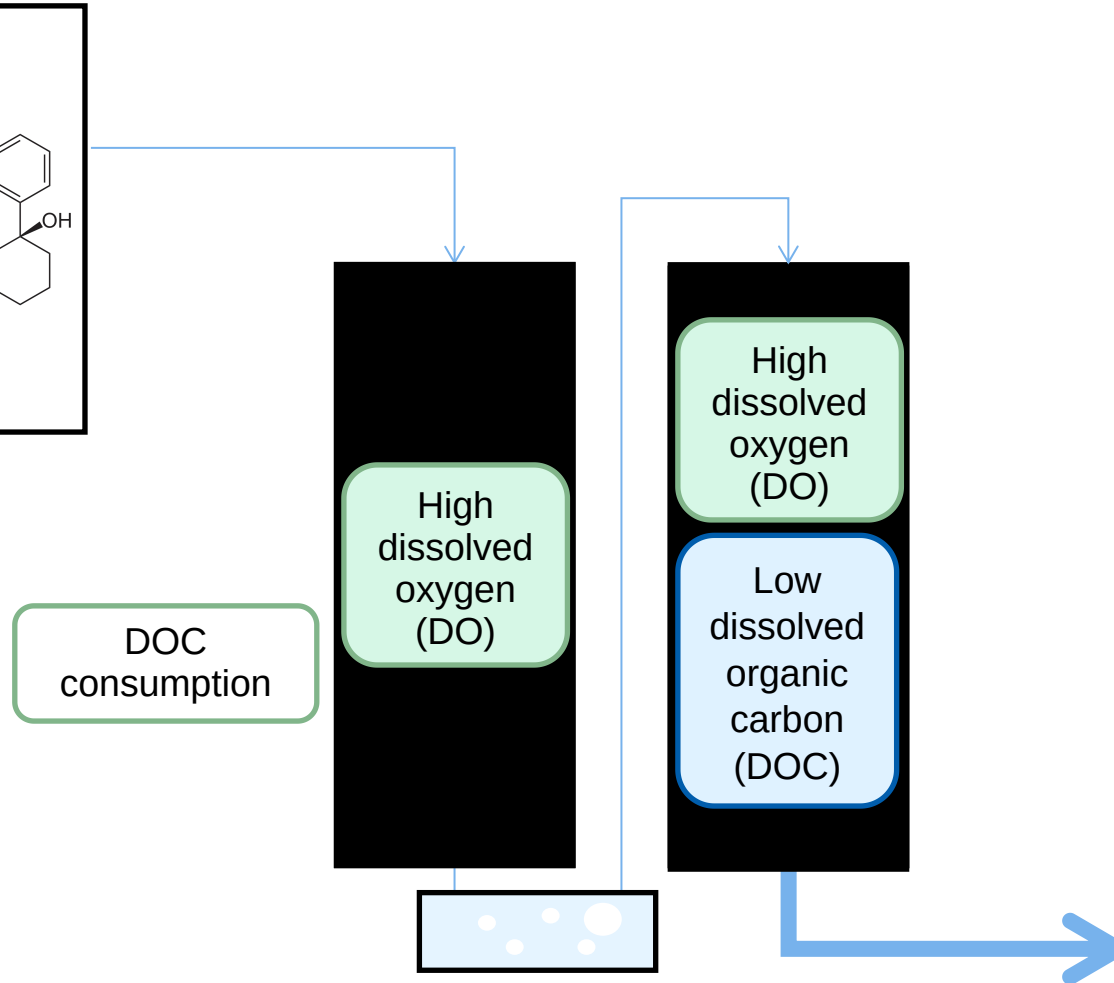
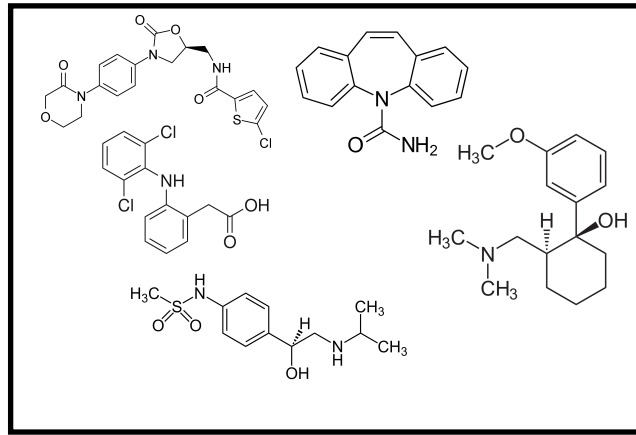

Molecular similarity hypothesis

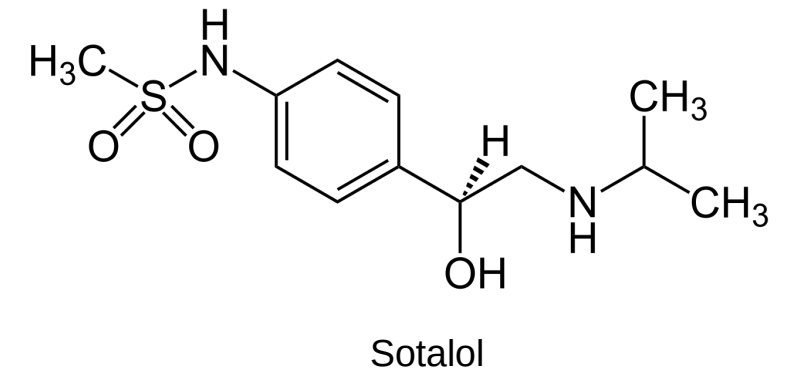
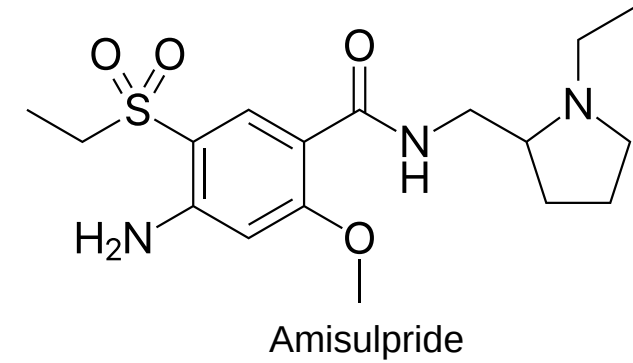
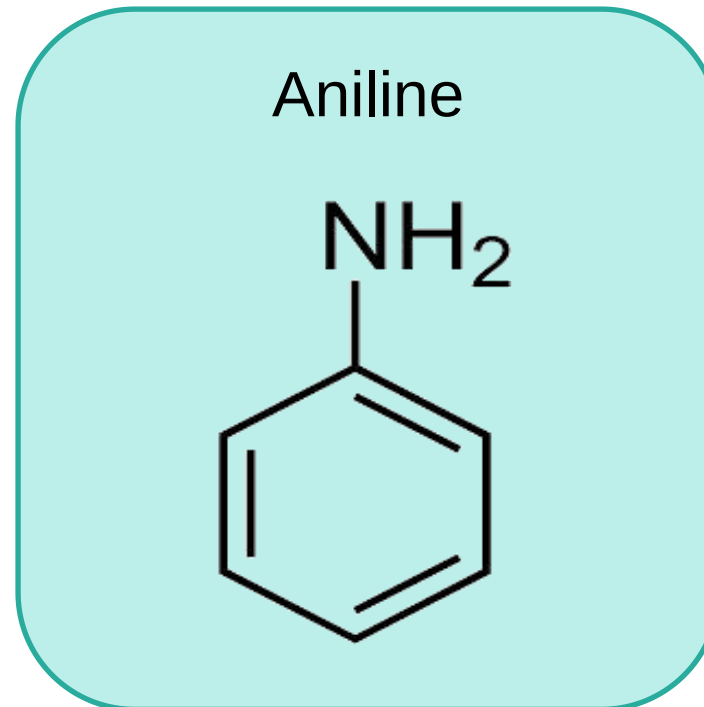
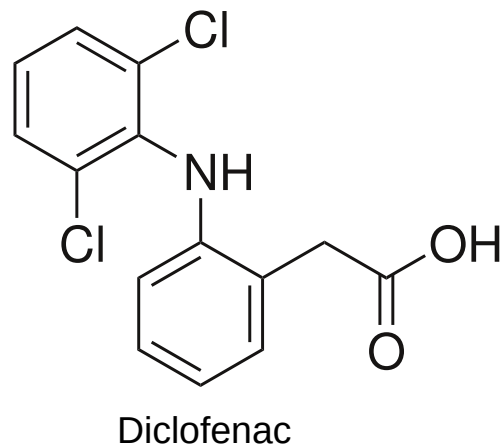
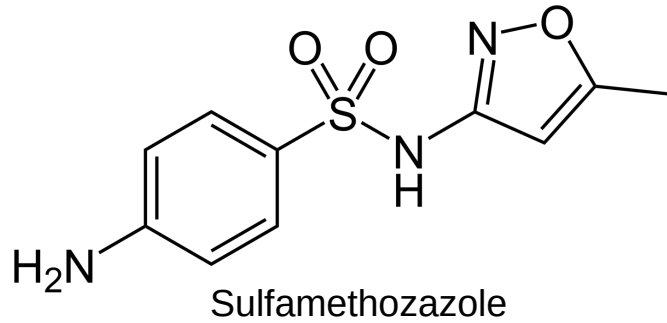

Single energy source

Disodium succinate

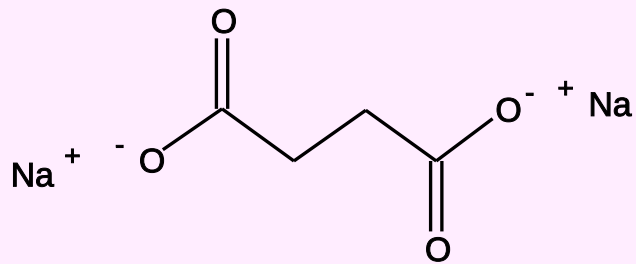

Aniline

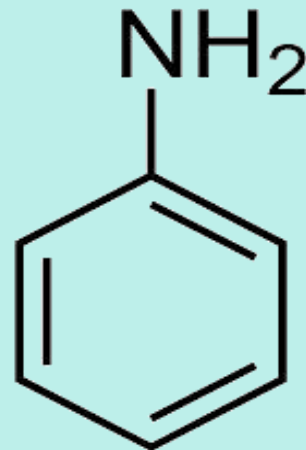



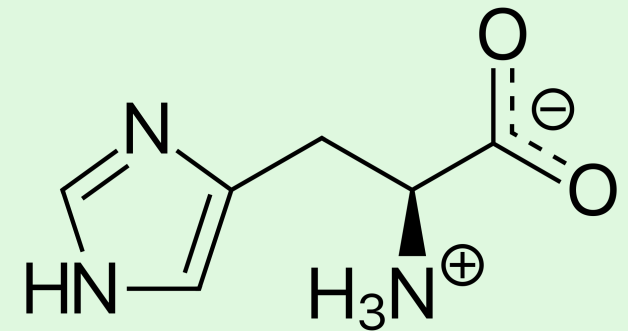

Histidine

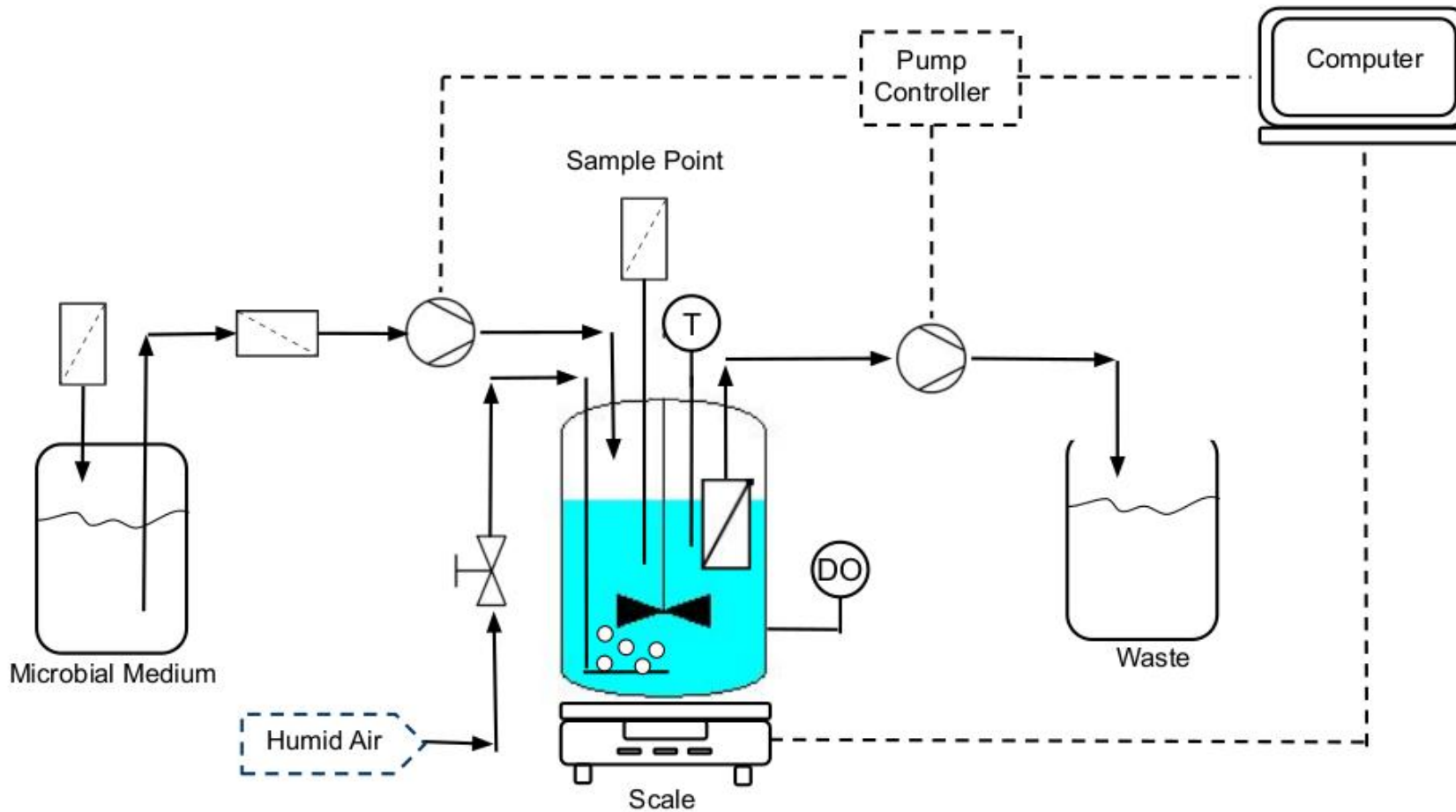

Lab-scale membrane bio-reactor



Legend	
Filter	
Pump	
Temperature/ DO Indicator	
Throttling Valve	
Membrane	



Activated sludge as inoculum

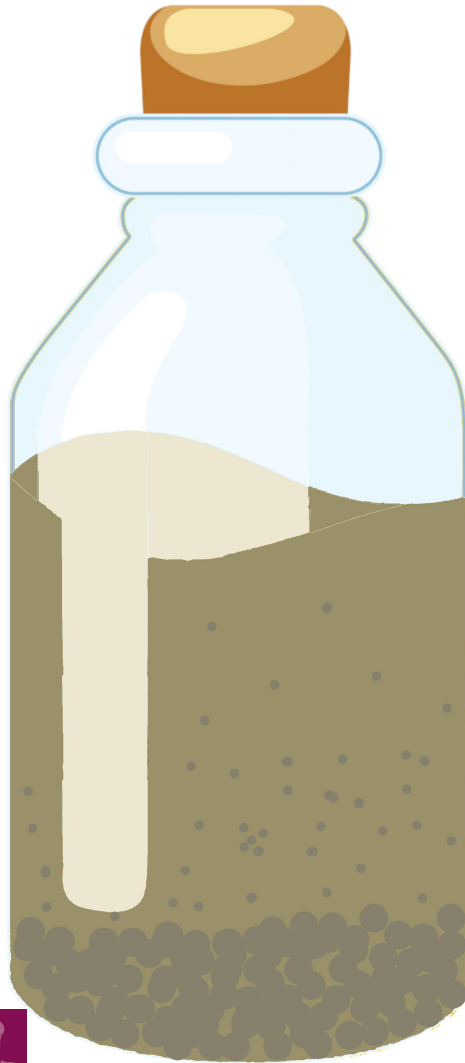

Oxic conditions

Pretreatment:
-Batch reactor operation

<https://www.freepik.com>

TOrCs biotransformation



2 weeks before



TOrCs biotransformation

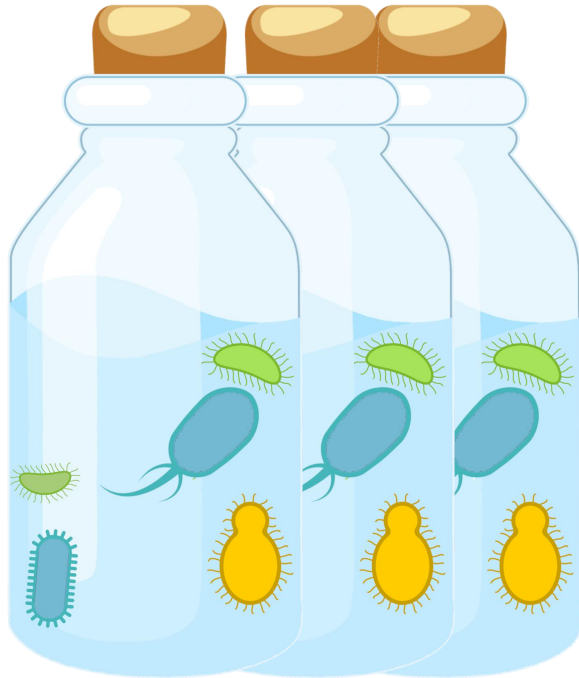

Add TOrCs in
feeding solution

Day 0



TOrCs biotransformation

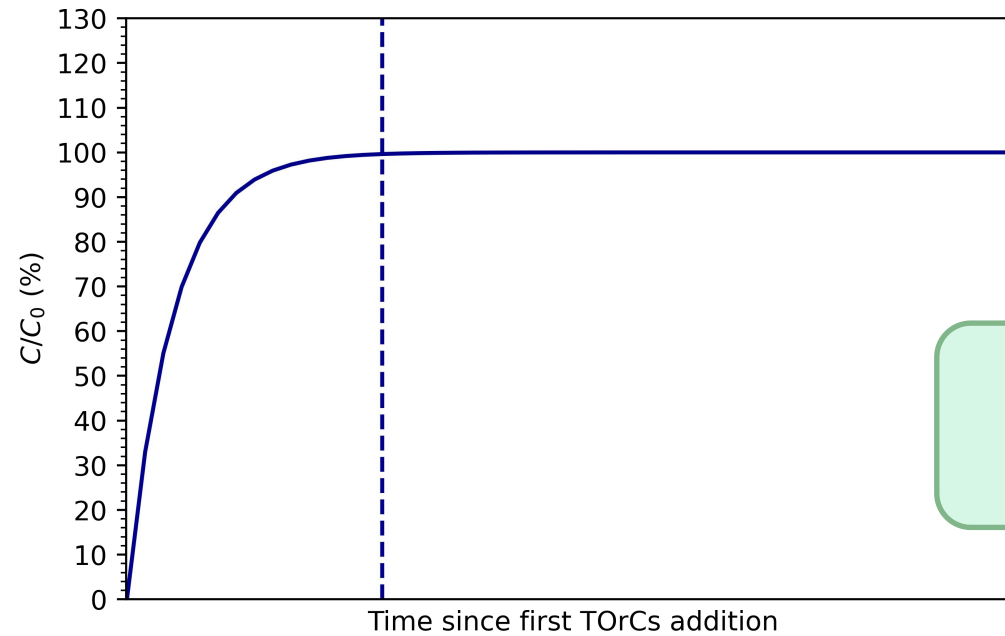
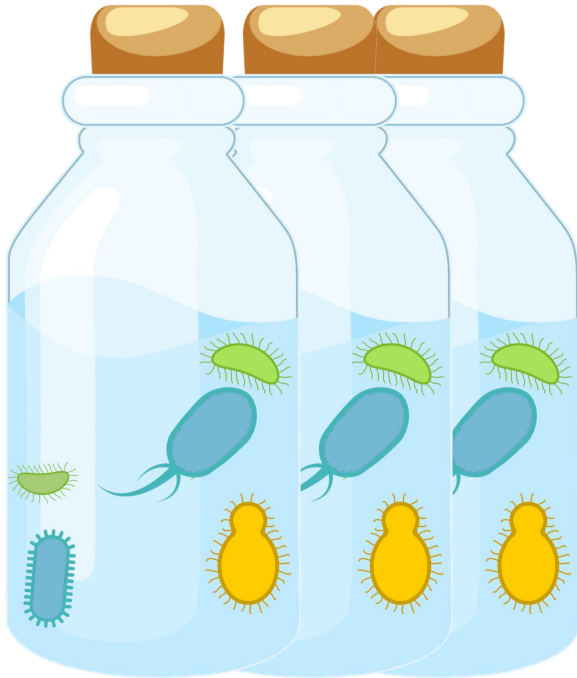

TOrCs
quantification

Day 5,6, and 7

Biotransformation of carbamazepine and sulfamethoxazole

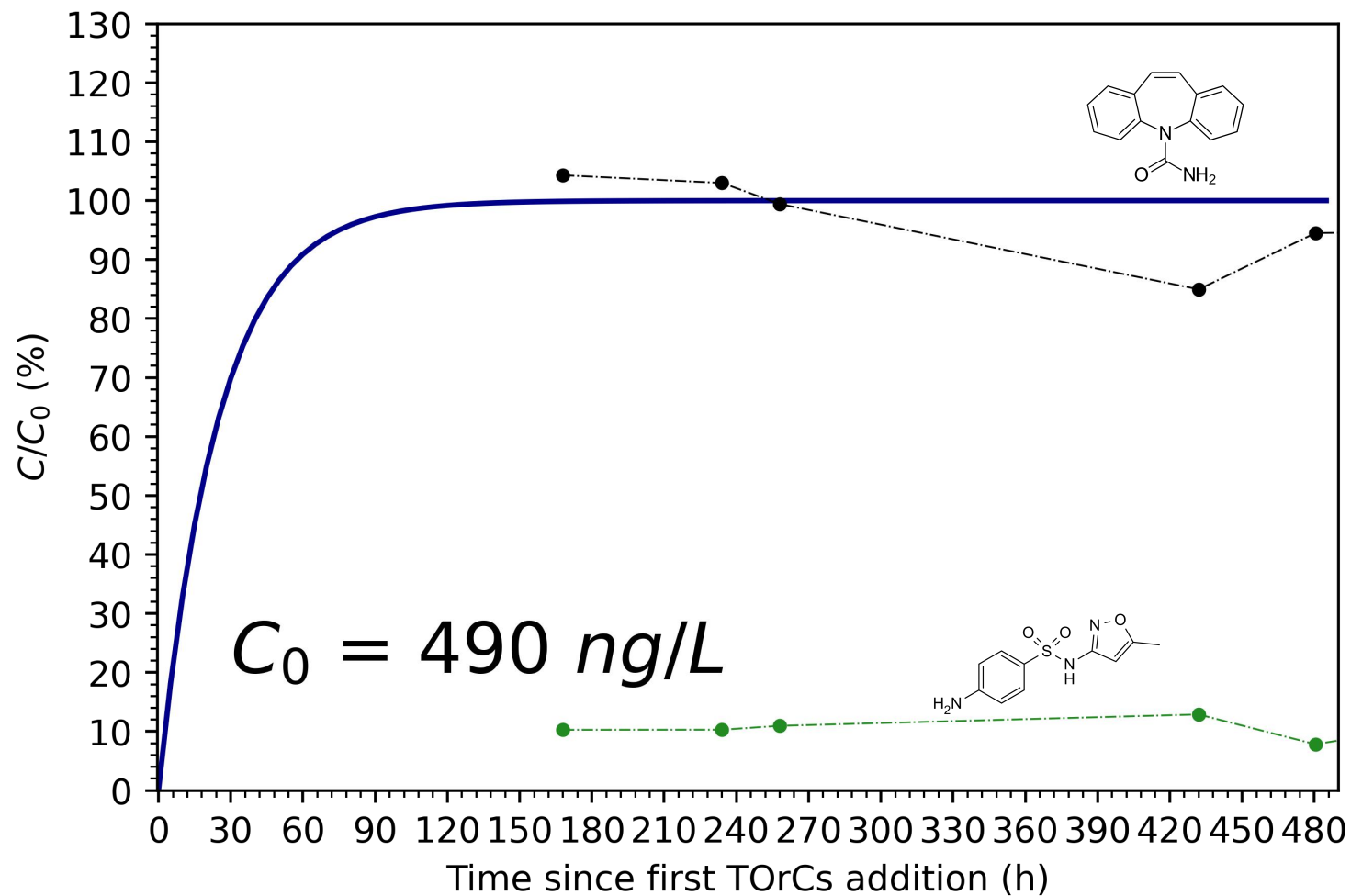

Selective biotransformation of TOrCs

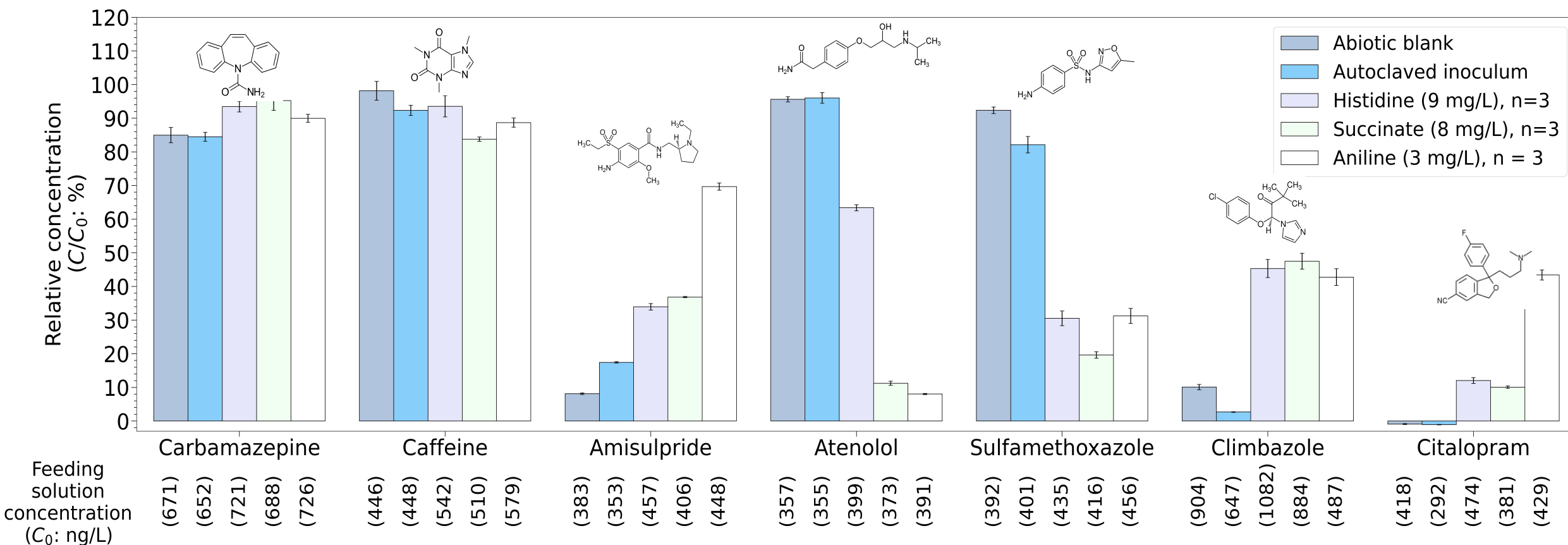

**TO BE
CONTINUED...→**



Thank you!



Nowelties

European Joint Doctorate

edwin.chingate@tum.de

This research was funded by the European Union's Horizon 2020 research and innovation program under the Marie Skłodowska-Curie grant agreement, MSCA-ITN-2018, [grant number 812880]

