



Miltenyi Biotec

MACSQuant[®] Instrument

User manual



MACS
QuantVYB

MACS
Quant16

MACS
Quant10

Copyright © 2020 Miltenyi Biotec and/or its affiliates. All rights reserved.

No part of this user manual may be reproduced, stored in a retrieval system, transmitted, published, or distributed in any form or by any means, electronically, mechanically, by photocopying, microfilming, recording, or otherwise, without the prior written consent of Miltenyi Biotec; however, notwithstanding the foregoing, the owners of the MACSQuant® Instrument may make copies solely for purposes of training personnel in the use and servicing of the unit within their business or organization. Maximal care has been taken by Miltenyi Biotec in the preparation of this user manual. However, Miltenyi Biotec shall not be liable for any technical or editorial errors or omissions contained herein or for incidental or consequential damages in connection with the furnishing, performance, or use of this document. The information in this document is provided "as is" without warranty of any kind, and is subject to change without notice. MACS, MACSima, MACSQuant, MACSQuantify, and the Miltenyi Biotec logo are either registered trademarks or trademarks of Miltenyi Biotec and/or its affiliates in various countries worldwide. All other trademarks mentioned in this document are the property of their respective owners and are used for identification purposes only. Unless otherwise specifically indicated, Miltenyi Biotec products and services are for research use only and not for therapeutic or diagnostic use.

MACSQuant[®] Instrument

User manual

Original instructions

Miltenyi Biotec B.V. & Co. KG
Friedrich-Ebert-Straße 68
51429 Bergisch Gladbach
Germany
Phone +49 2204 8306-0
Fax +49 2204 85197
macsde@miltenyi.com
www.miltenyibiotec.com

Read the chapter Important safety information and all other information in this user manual before using the instrument



Before using the MACSQuant Instrument (MACSQuant Analyzer 10, VYB, or Analyzer 16), read the chapter **Important safety information** and all other information contained in this user manual, including any safety and operating instructions. Pay special attention to all warnings displayed on the instrument. Failure to read and follow these guidelines could lead to improper or incorrect usage and result in damage to the instrument. Improper usage could also cause severe personal injury, death, unpredictable results, instrument malfunction, and premature wear to components shortening the lifetime of the instrument. Such actions may void your warranty. Keep the user manual and any other safety and operating instructions provided with the instrument in a safe place accessible to all users for future reference.

If you have a serious concern regarding the safe use of your instrument, contact your authorized Miltenyi Biotec service provider or call Miltenyi Biotec Technical Support.

Content

Important safety information	6
Wichtige Sicherheitshinweise	16
Información importante de seguridad	26
Informations de sécurité importantes	36
Importanti istruzioni di sicurezza	46
1 Introduction	57
1.1 Intended use	57
1.2 Key features of the MACSQuant® Instrument	57
2 Installation	61
2.1 Components included in the delivery	61
2.2 Consumables	62
2.3 Accessories	62
2.4 Service contracts	62
2.5 Assembly	63
2.5.1 Install the fluid bottles	63
2.5.2 Install the Single tube rack	65
2.5.3 Connect the instrument to the power supply	65
2.5.4 Installation of the MACSQuant® Column	66
2.5.5 Install the webcam	67
2.5.6 Install the needle guard	68
2.5.7 Install the MACS® MiniSampler Plus	69
2.5.8 Install the Chill Rack and Universal Reagent Rack	71
2.5.9 Installation checklist	73
3 Operating the instrument	75
3.1 Switching on the instrument	75
3.2 Shutting down	75
3.2.1 Manual shutdown	75
3.2.2 Automatic shutdown	75

3.3 Long-term storage	76
4 Calibration	77
4.1 Calibrating the sample uptake unit	77
4.1.1 Calibrating the robotic needle arm	77
4.1.2 Calibrating the Single tube rack	79
4.1.3 Calibrating the Chill 5 Rack	79
4.1.4 Calibrating the 96-well plate	79
4.1.5 Calibrating the MACSPlex Filter Plate	80
4.1.6 Calibrating the MACS® Reagent Rack 4	80
4.1.7 Calibrating the Universal Reagent Rack	81
4.1.8 Calibrating the custom 96 racks	81
4.2 Calibrating the rack detection	81
4.2.1 Calibrating the Single Tube rack detection	81
4.2.2 Calibrating the rack detection	82
5 Hardware monitor	85
5.1 Hardware monitor	85
5.1.1 Fluidics	85
5.1.2 The Sample uptake unit	86
5.1.3 Lasers and detectors	86
5.2 Instrument status LEDs	87
6 Live Support	89
6.1 The MACSQuant® Live Support	89
7 Maintenance	91
7.1 Decontaminating the instrument	91
7.2 Exchanging fluid bottles	91
7.3 Exchanging the MACSQuant® Column	91
7.4 Exchanging hydrophobic air filters	92
7.5 Long-term storage of the instrument	92
7.6 Cleaning programs	92

8	Troubleshooting	93
8.1	Column leakage	93
8.2	Syringe pump leakage	93
8.3	Air bubbles during measurement / no event acquisition	93
8.4	Excessive debris is present during acquisition	93
8.5	Touchscreen remains dark	94
9	Technical data and specifications	95
9.1	EC / EU Declaration of Conformity	99
9.2	EC / EU Declaration of Conformity	100
9.3	EC / EU Declaration of Conformity	101
9.4	Technical data and specifications of the MACS MiniSampler Plus	103
9.5	EC / EU Declaration of Conformity	103
10	Technical support	105
11	Limited warranty	107
12	Index	109

Warnings and precautions

⚠ WARNING The instrument is designed for safe use when installed correctly, operated by trained personnel, operated in accordance with general safety practices and the instructions in this user manual.

The guidelines in this section explain the potential risk associated with operating this instrument and provide important supplemental safety information to minimize the risks. Follow the instructions carefully to protect yourself, others, and the equipment from potential hazards and create a safe work environment. Use this instrument only as specified by the manufacturer to avoid damage of equipment and injury to personnel. Always follow local working area safety instructions and laboratory policies as well as standards for health, safety and prevention of accidents. Contact the local authorities governing electrical power supply, building constructions, maintenance, or safety for more information about the safe installation and operation of the instrument.

Hazard levels











Signal words are used to identify safety and property damage messages. The following signal words are used throughout this user manual.

⚠ WARNING or **WARNING!** indicates a potentially hazardous situation, which, if not avoided, could result in death or serious injury.

⚠ CAUTION or **CAUTION!** indicates a potentially hazardous situation, which, if not avoided, may result in minor or moderate injury. It may also be used to alert against unsafe practices.

Safety symbols

The following symbols are used to highlight conditions that could cause injury to personnel.

-  Safety alert. Risk of danger. The documentation needs to be consulted in all cases where this safety alert symbol is used on the instrument, in order to find out the nature of the potential hazard and any actions that have to be taken.
-  Risk of electric shock.
-  Strong magnetic field.
-  Persons carrying a pacemaker or other electronic implants must maintain distance.
-  Risk of crushing and shearing of bodily parts.
-  Hazardous optical radiation.
-  Hazardous laser radiation.
-  Biohazard. Risk of contamination if potentially dangerous biological material is used.
-  Protective conductor terminal. Symbol is attached on the inside of the instrument. Information for service personnel.
-  On (Power supply).
-  Off (Power supply).

Safety labels

Note the hazard points and safety symbols of the instrument. All safety labels and safety markings must be kept clean and legible. Inspect the safety labels and safety markings regularly and replace them if not legible or identifiable from a safe viewing distance. Contact Miltenyi Biotec for replacement labels.

Safety labels on the instrument

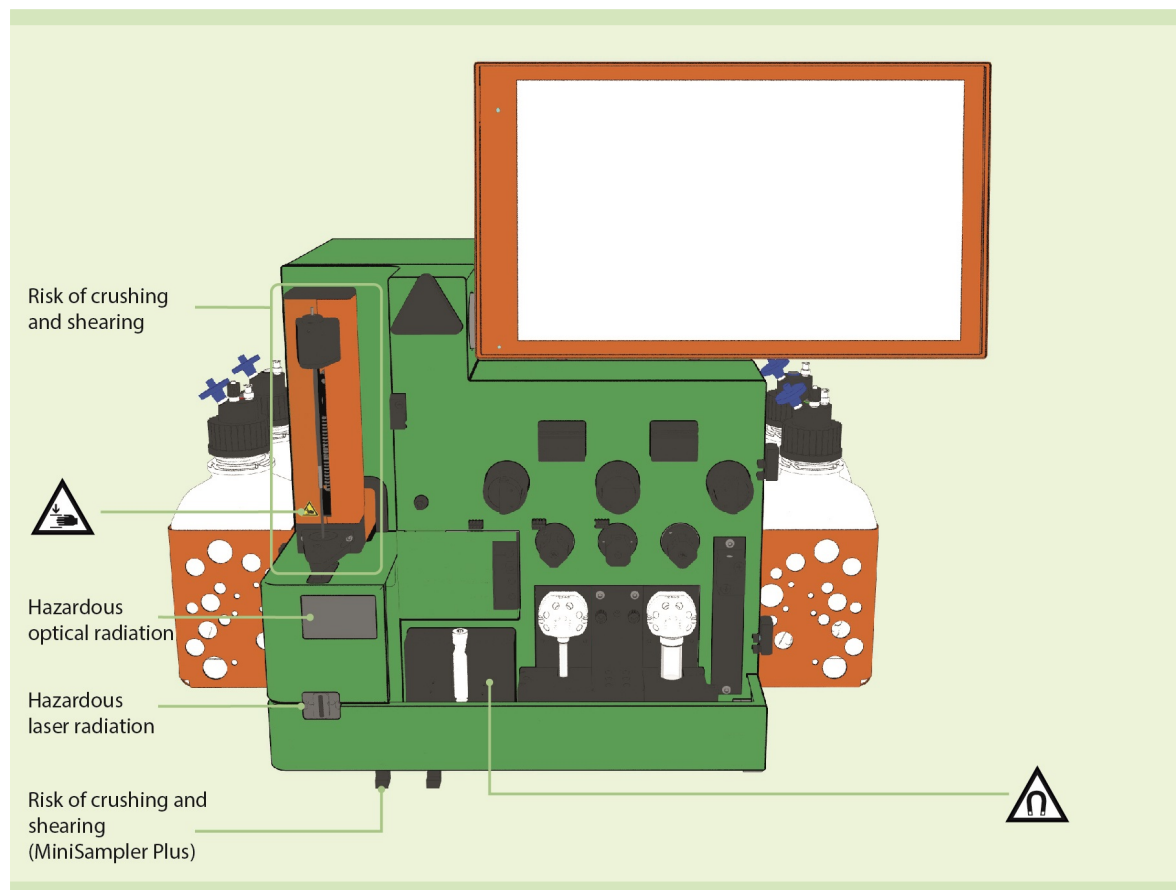

Figure 1: Hazard areas and safety symbols on the front of the MACSQuant® Instrument.

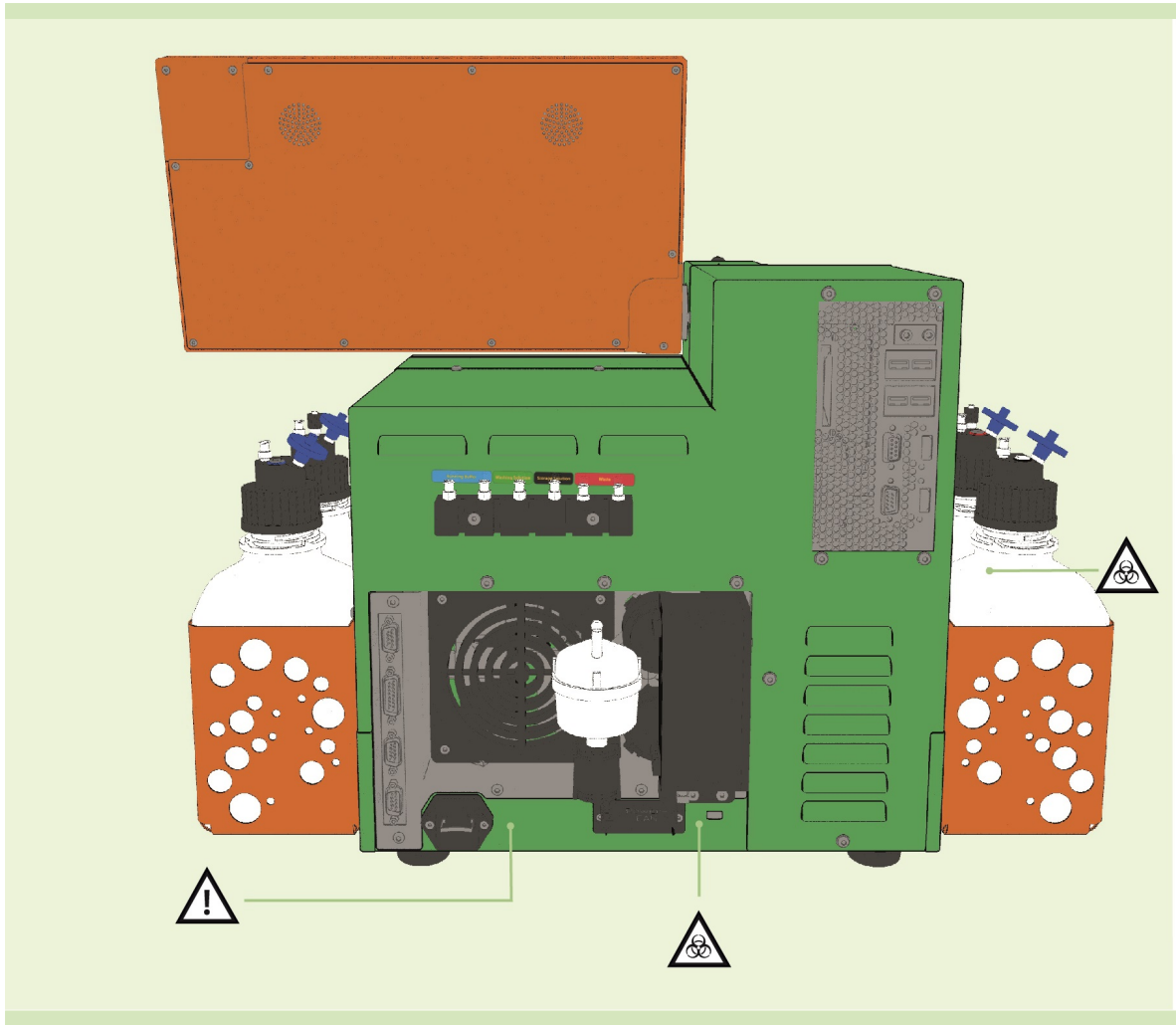

Figure 2: Hazard areas and safety symbols on the rear side of the MACSQuant® Instrument.

General safety instructions



Safe operation of the instrument is no longer ensured if the instrument is not working properly and/or the displayed instructions or messages advise you to contact Technical Support. Immediately switch off and unplug the instrument from the power outlet and contact an authorized Miltenyi Biotec service provider or Miltenyi Biotec Technical Support.

Electricity and fire hazards



Potential risks arising from electrical devices include electric shock, short, and overheating. Electric shock may lead to severe personal injury or death.

An electric short and overheating may lead to the spread of fire. Electronic equipment might emit sparks, which could ignite combustible vapors or material resulting in explosion or fire.

Do not use the instrument in areas classified as hazardous locations; for example, in oxygen-laden environments. If flames or smoke appear, immediately switch off the power supply, unplug the instrument from the electrical outlet, and contact an authorized Miltenyi Biotec service provider or Miltenyi Biotec Technical Support.

The instrument housing is designed to lower the risk of electric shock, short, and spread of fire. **Except for the front access covers, do not remove or penetrate any cover, nor any cover of other accessory hardware supplied by Miltenyi Biotec. Only authorized personnel is allowed to remove any other cover of the instrument. Never push a foreign object through an opening into the instrument.**

Do not use the instrument if

- it has been opened or disassembled
- it has been dropped or damaged
- it has damaged or broken parts
- it has a damaged power cable
- an object has entered through the ventilation slots
- an object has been dropped into the instrument

The instrument is intended for indoor use only. If liquids enter the instrument, it may lead to electric shorts, shock, or fire. Take special care while handling liquids.

Do not allow liquids to enter the interior of the instrument. Protect the instrument against accidental spillages and splashes. Clean up spillages immediately. Do not operate the instrument if liquids have entered the instrument. Do not use the instrument in a wet and damp location. Avoid areas with high humidity or condensation. Moving the instrument from a cold environment – such as a cold room at 5°C – to room temperature may cause condensation inside the instrument. In such cases, wait for the instrument to dehumidify before operating it.

Before cleaning, unplug the instrument. Do not use liquid or aerosol cleaning agents, always use a damp cloth.

Protect the instrument from overheating. Do not use the instrument in areas with more than 25°C. Ensure adequate air circulation in the room when the instrument is operated. Allow sufficient air circulation around the instrument – at least 15 cm on all sides – during operation. **Do not place the instrument near radiators, heat registers, stoves, or other equipment (including amplifiers that generate heat. Protect the instrument from direct sunlight. Do not cover the slots and openings of the instrument as these are provided for ventilation.** Do not place the instrument in a built-in rack or similar confined spaces unless the space has been specifically designed to provide proper ventilation. Follow the mounting instructions for the instrument.

The instrument is equipped with a three-wire electrical grounding-type plug that has a third pin for grounding. This plug fits in a grounded power outlet only. This is a safety feature. **Do not try to insert the plug into a non-grounded power outlet.** If you cannot insert the plug into the outlet, contact your local electrician to replace the outlet.

Only peripheral devices that comply to UL 60950 are allowed to be connected to the RS232 connector labeled COM1. Only original MACSQuant Instrument equipment should be attached to the connectors labeled External CAN.

Only the 2D code reader that was delivered with the instrument should be connected to the RS232/BCR port. External laser devices connected to the RS232/BCR port have to comply with the standard IEC 60825-1.

In order to ensure electromagnetic compliance, connect peripheral devices only with double-shielded cables and only use the power cable and the keypad included in delivery. Only use connector cables less than 3 m in length. Use the keypad with MACSQuant® Instrument models only.

Ensure that the main switch as well as the plug of the power cable are easily accessible and located as close to the operator of the instrument as possible. If it is necessary to disconnect the power supply, unplug the cable from the power outlet.

The instrument should only be operated from a power source that meets the specifications mentioned on the product's electrical ratings label. If you have questions about the type of power source to use, contact your authorized Miltenyi Biotec service provider or local power company.

Do not use extension cords or power strips. Do not overload an electrical outlet.



Strong magnetic field

The instrument is equipped with an extremely powerful magnet. There is a risk of severe personal injury for persons carrying pacemakers, brain shunts or electronic medical implants.



Persons carrying pacemakers or electronic medical implants must maintain distance. Keep all magnetic storage devices, electronic equipment and magnetizable objects at a distance of at least 20 cm.



Mechanical hazards

Moving and revolving parts are potential mechanical hazards.

Do not open the front access covers while the instrument is in operation. Do not obstruct the movement of the robotic needle arm and accessory hardware during operation. There is a risk of puncturing, crushing and shearing bodily parts. Keep fingers etc. away from all moving parts of the instrument or accessory hardware. Do not circumvent any safety measures or devices.

Do not touch fluid pumps or adjust the tubing while the instrument is in operation. Always switch off the instrument before adjusting any part of the fluidic system. Always stop or abort a procedure before handling accessory hardware, e.g., MACS MiniSampler Plus, or loading/removing tubes from the tube rack. Operate only with attached needle guard.



Optical radiation hazards

The MACSQuant® Instrument is classified as a Class 1 M laser product per standard IEC 60825-1. The MACSQuant Instrument is equipped with three continuous-wave lasers (laser class 3B). These lasers are secured by a protective housing. **Do not remove the protective housing. Use of controls or adjustments or performance of procedures other than those specified herein may result in hazardous radiation exposure.**

The instrument is equipped with four vertical cavity surface emitting lasers (VCSEL for automated rack detection (Class 1M. The radiation is not visible.

Invisible laser radiation. Do not expose users of telescopic optics.

Do not look at the VCSEL port through optical instruments such as magnifying glasses. Looking at the VCSEL port from a distance less than 100 mm may damage the eyes.



The instrument is equipped with a 2D Code Reader with powerful light emitting diodes (LEDs) for illuminating the reading area. Powerful LEDs are also used to illuminate the fluid bottles as well as the waste bottle. According to the international standard IEC 62471, this lamp system has an exposure hazard value (EHV) of 0.91 and is in excess of the Exempt Risk Group.

Do not remove the protective housing.

Do not remove the bottle holders unless integrating the instrument into a liquid handling system. If the bottle holders are removed, make sure users are not exposed to emitted LED radiation.

Do not look directly at laser or LED radiation or reflected laser or LED radiation from a mirrored surface. Otherwise, eye injury may result. Do not direct the laser beam at others.

Be careful of the path of the light beam or reflection from a mirrored surface. Take care during installation of the instrument that the path of the light beam is not at the same height as the human eye during operation. Do not allow water, oil, dust or other foreign substances to stick to the 2D Code Reader aperture window. This may cause reading errors. Be sure to stop the laser emission before cleaning the scanner. Otherwise, exposure to the light may cause eye injury. Use a soft, dry cloth to wipe any substances from the scanner. Do not use alcohol or other cleaning substances.

Radiation of disassembled units may lead to eye injuries. **Do not disassemble, modify, or remove the installed laser or LED radiation sources. The laser or LED radiation sources do not automatically stop emitting when disassembled.**

The hazard distance (HD) for the Exempt Risk group is 61 cm. The hazard distance for Risk group 1 is 20 cm.

	Output power	Pulse time	Wavelength
MACSQuant Analyzer 10			
Rack Detection	3.3 mW	215 µs	850 nm
Internal Laser 1	30 mW	Continuous	488 nm
Internal Laser 2	21.5 mW	Continuous	404 nm
Internal Laser 3	40 mW	Continuous	640 nm
MACSQuant VYB			
Rack Detection	3.3 mW	215 µs	850 nm
Internal Laser 1	50 mW	Continuous	488 nm
Internal Laser 2	40 mW	Continuous	404 nm
Internal Laser 3	100 mW	Continuous	561 nm
MACSQuant Analyzer 16			
Rack Detection	3.3 mW	215 µs	850 nm
Internal Laser 1	50 mW	Continuous	488 nm
Internal Laser 2	65 mW	Continuous	404 nm
Internal Laser 3	72 mW	Continuous	642 nm

Table 2.1: Laser output power, pulse time, and wavelength.

Chemical and biological hazards



Depending on the biological material used, contamination infection may lead to severe personal injury or death. All clinical samples must be considered potentially infectious.

If biohazardous material is or has been used, the operator must choose and wear personal safety equipment as indicated in the warnings and precautions for the particular substance. The above safety precaution also accounts for any hazardous chemical, including toxic or corrosive chemicals, acidic or radioactive substances that may be present in the sample.

Wear protective gloves and clothing, as well as safety glasses to prevent contact of the substance with skin and eyes. Defective or inadequate safety equipment is hazardous. If hazardous material has been used or spilled, care must be taken to thoroughly decontaminate the instrument. It is strictly prohibited to continue to handle contaminated accessories or parts of the instrument.

Also protect mouth and nose as aerosols might leak from the system. The instrument must be operated in a safety hood if hazardous or unknown material is being processed.

All liquid and solid waste must be considered hazardous and, must be therefore handled taking universal laboratory precautions. Waste disposal must be in accordance with any local regulations.

Before disposal, decontaminate all tubes and other consumables that were in contact with biohazardous material. Liquid waste must be autoclaved or decontaminated using a disinfectant that is appropriate for the specific pathogen, e.g., 10% bleach, isopropyl alcohol, or 70% ethanol.

Failure of parts containing biohazardous material or liquids that have been in contact with such materials could cause a hazard.

Always inspect the fluidics system (complete tubing set, reservoirs, bottles and their closures, valves, columns, diluters, peristaltic pumps, and uptake needle) before switching on the instrument. If leakage has been detected, replace all damaged parts before switching on the instrument. If damaged part cannot be replaced, unplug and do not use the instrument.

Servicing and transportation

Improper or incorrect servicing or repair of the instrument can cause hazards to users, lead to unpredictable results, cause instrument malfunctions or damage, as well as premature wear and tear and reduced life of the instrument. It may also void your warranty.

Unless otherwise specifically noted in this user manual or other Miltenyi Biotec documentation, do not service the instrument yourself. Servicing and repair must be performed by qualified service personnel.

When replacement or spare parts are required, ensure that the service provider uses only genuine Miltenyi Biotec parts, or third-party parts specified and recommended by Miltenyi Biotec. Using unauthorized parts can cause malfunctions of the instrument and impair results. Miltenyi Biotec does not honor any warranty or accept any responsibility for instrument failure or damages resulting from the use of inappropriate parts. After completing any service or repair work, ensure that your authorized Miltenyi Biotec service provider performs all safety checks as required by the repair procedure to ensure that the instrument is operating correctly.

Only use options and upgrades recommended by Miltenyi Biotec. Inquire with your local Miltenyi Biotec representative about Miltenyi Biotec's extensive instrument service and support arrangements, or refer to www.miltenyibiotec.com/support.

The instrument should be transported with care in packaging specified by Miltenyi Biotec. Internal damage can occur if the instrument is subjected to excessive vibration or is dropped. If the instrument needs to be shipped back to the manufacturer for service, decontaminate the instrument to remove any hazardous material prior to shipment. If you have questions regarding proper decontamination or shipment, contact Miltenyi Biotec Technical Support for assistance.

Disposal



Waste of Electrical and Electronic Equipment (WEEE) customer information

Dispose of your end-of-life Miltenyi Biotec products in accordance with the applicable WEEE and hazardous waste disposal legislation, which may differ by country or region.

Electrical and electronic equipment may contain hazardous substances which may have a serious detrimental effect on the environment and/or human health. That is why all equipment must be specifically collected and treated by designated waste facility centres and by qualified WEEE compliance schemes. By ensuring that you dispose of your unwanted electrical and electronic equipment according to the applicable WEEE and hazardous waste disposal legislation, you are helping to preserve our natural resources and protect human health.

Miltenyi Biotec is committed to protecting the environment. Miltenyi Biotec offers product end-of-life return programs in many countries, and partners with licensed WEEE compliance schemes throughout the world. Miltenyi Biotec lets you recycle your end-of-life Miltenyi Biotec equipment free of charge. The terms and availability of this offer vary by geography because of differences in regulatory requirements. Note that, depending on the type and use of your equipment, additional requirements may apply.

For more information, or if you wish to dispose of your end-of-life Miltenyi Biotec equipment, contact your local Miltenyi Biotec representative or Miltenyi Biotec Technical Support.

EN

DE

ES

FR

IT

IT	FR	ES	DE	EN
----	----	----	----	----

Warnungen und Sicherheitshinweise



WARNING Das Instrument ist für einen sicheren Betrieb ausgelegt, wenn es richtig installiert, von geschultem Personal bedient und entsprechend der Sicherheitsrichtlinien und Anweisungen in diesem Benutzerhandbuch eingesetzt wird.

Die Sicherheitsrichtlinien in diesem Kapitel erläutern die Gefahren, die sich aus dem Betrieb dieses Geräts ergeben können und erhalten wichtige zusätzliche Informationen wie diese Risiken zu minimieren sind. Befolgen Sie diese Sicherheitshinweise sorgfältig um sich selbst, andere, und das Gerät vor möglichen Gefahren zu schützen und ein sicheres Arbeitsumfeld zu schaffen. Benutzen Sie das Gerät ausschließlich nach Angaben des Herstellers, um Sach- und Personenschäden zu vermeiden. Befolgen Sie örtliche Arbeitsschutzbestimmungen, Laborrichtlinien sowie Sicherheitsnormen und Unfallverhütungsvorschriften. Wenden Sie sich für weitere Informationen zu Stromversorgung, Gebäudeinstallation, Wartung und sichere Installation des Gerätes an die örtlichen Behörden und Ihren Stromversorger.

Gefahrenstufen

Signalwörter sollen auf Sicherheits- und Sachschadenshinweise aufmerksam machen. Folgende Gefahrensymbole werden in diesem Benutzerhandbuch verwendet.













oder **WARNING!** bezeichnet eine Gefahrensituation, die, falls sie nicht vermieden wird, zum Tode oder schwerwiegenden Verletzungen führen kann.



oder **CAUTION!** bezeichnet eine Gefahrensituation, die, falls sie nicht vermieden wird, zu leichteren oder mittelschweren Verletzungen führen kann. Es kann auch verwendet werden, um vor unsicherem Gebrauch zu warnen.

Gefahrensymbole

Die folgenden Symbole werden benutzt um Gefahrensituationen anzuzeigen, die zu Personenschäden führen können.

-  Warnzeichen. Gefahrenrisiko. Dieses Benutzerhandbuch muss immer konsultiert werden, wenn dieses Warnzeichen benutzt wird, um mehr über die möglichen Gefahren und entsprechende Handlungsanweisungen zu erfahren.
-  Gefahr durch Stromschlag.
-  Starkes Magnetfeld.
-  Personen mit Herzschrittmacher oder anderen elektronischen medizinischen Implantaten müssen Abstand halten.
-  Quetsch- und Schergefahr.
-  Gefahr durch optische Strahlung.
-  Gefahr durch Laserstrahlung.
-  Biologische Gefährdung. Risiko der Kontamination, wenn mit möglicherweise gefährlichen biologischen Substanzen gearbeitet wird.
-  Schutzleiteranschluss. Das Symbol ist innerhalb des Gerätes angebracht. Dies ist ein Hinweis für Servicepersonal.
-  An (Stromversorgung).
-  Aus (Stromversorgung).

EN

DE

ES

FR

IT

Sicherheitskennzeichnungen

Bitte achten Sie auf die Gefahrenpunkte und die Gefahrensymbole des Instruments. Alle angegebenen Sicherheitsaufkleber und Markierungen müssen sauber und lesbar bleiben. Überprüfen Sie die Aufkleber regelmäßig und ersetzen Sie diese, wenn sie aus seiner sicheren Entfernung nicht mehr lesbar sind. Kontaktieren Sie Miltenyi Biotec, um Ersatzaufkleber zu erhalten.

Sicherheitskennzeichnungen auf dem Instrument

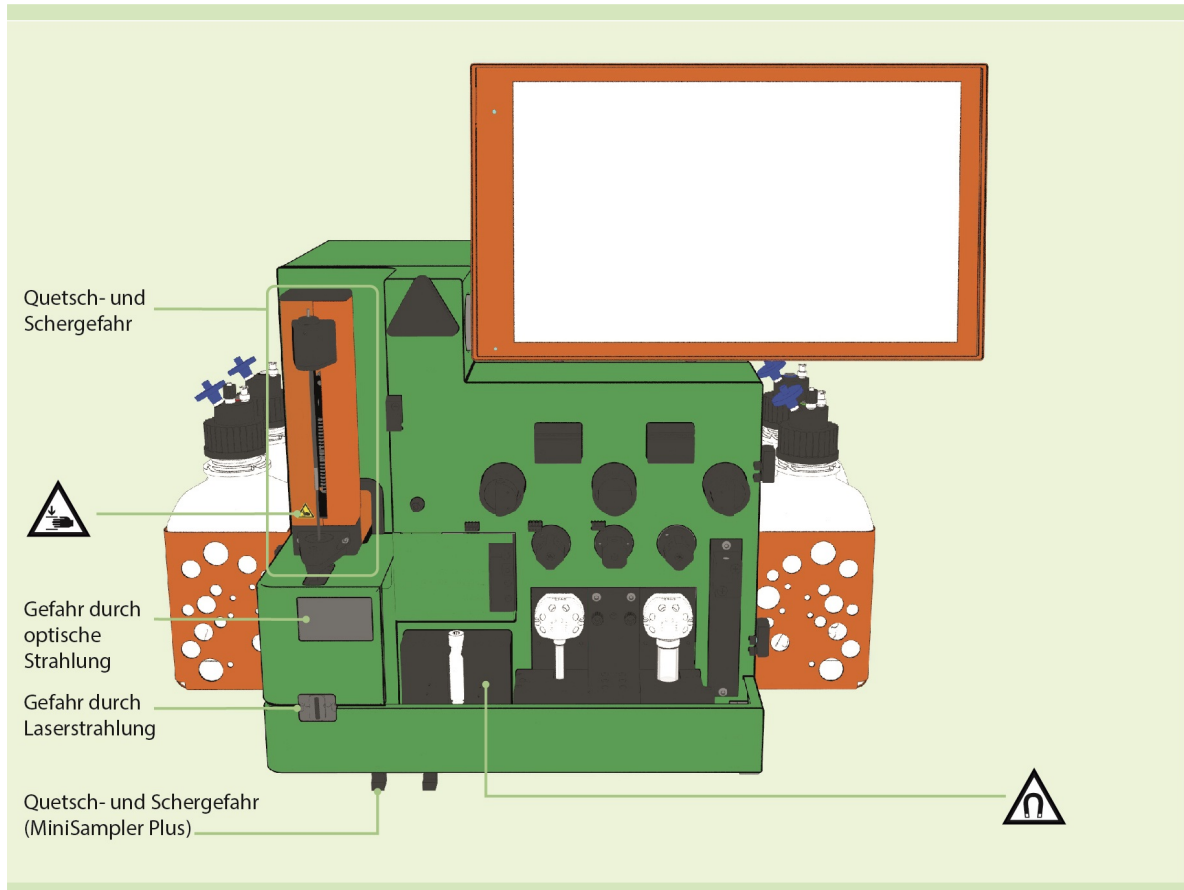

Figure 1: Gefahrenquellen und Gefahrensymbole auf der Vorderseite des MACSQuant® Instruments.

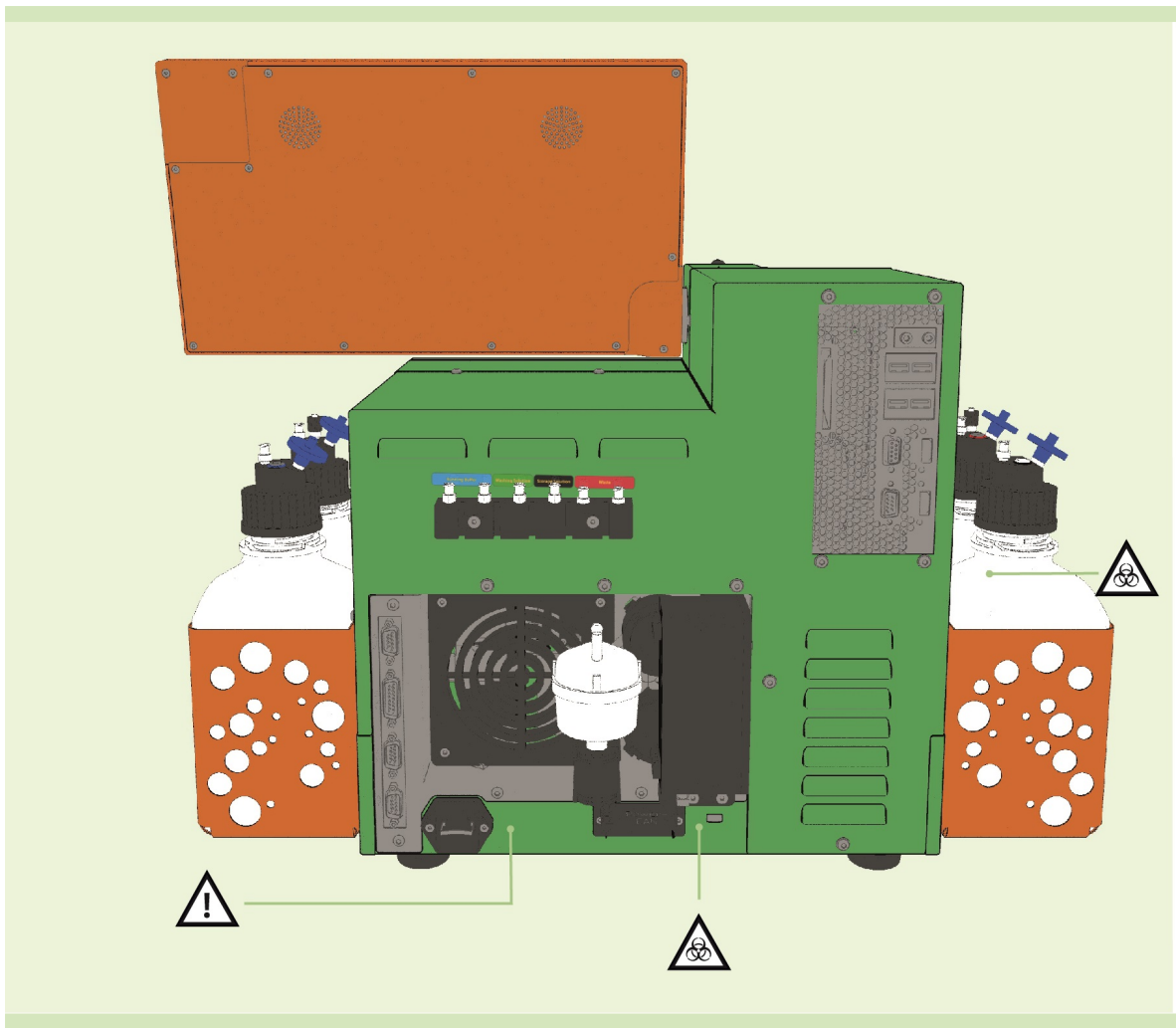

Figure 2: Gefahrenquellen und Gefahrensymbole auf der Rückseite des MACSQuant® Instruments.

Allgemeine Sicherheitshinweise



Die Betriebssicherheit des Gerätes ist nicht länger gewährleistet, wenn Ihr Gerät nicht einwandfrei funktioniert und/oder Anzeigen auf dem Display Sie dazu auffordern den technischen Kundendienst zu kontaktieren. Schalten Sie das Gerät sofort aus, ziehen Sie den Netzstecker und kontaktieren Sie einen autorisierten Miltenyi Biotec Servicedienstleister oder den Miltenyi Biotec Technical Support.

Elektrische Gefährdung und Brandgefahr



Elektrische Geräte bergen das Risiko eines Stromschlags, Kurzschlusses und der Überhitzung. Ein Stromschlag kann zu schweren Verletzungen und bis zum Tod führen.

Verwenden Sie nur doppelt abgeschirmte Kabel zum Anschluss von Peripheriegeräten sowie das mitgelieferte Netzanschlusskabel und die mitgelieferte Tastatur, um die elektromagnetische Verträglichkeit sicherzustellen. Es dürfen nur Anschlusskabel mit einer Länge von max. 3 Metern verwendet werden. Nutzen sie die Tastatur nur mit MACSQuant® Instrument Modellen.

Stellen Sie sicher, dass der Hauptstromschalter ebenso wie der Netzstecker für das Stromkabel leicht zugänglich sind und sich in möglichst unmittelbarer Nähe zum Bediener des Gerätes befinden. Sollte es erforderlich sein, die Stromzufuhr zu unterbrechen, ziehen Sie den Netzstecker aus der Steckdose.

Das Gerät sollte nur von einer Stromquelle aus betrieben werden, die den elektrischen Angaben auf dem Typenschild entspricht. Sollten Sie Fragen zur Art der Stromversorgung haben, wenden Sie sich an einen autorisierten Miltenyi Biotec Servicedienstleister oder Ihren lokalen Stromversorger.

Benutzen Sie keine Verlängerungskabel oder Steckdosenleiste. Überlasten Sie eine Steckdose nicht.

Ein elektrischer Kurzschluss sowie Überhitzung kann einen Brand auslösen. Elektrische Geräte können Funken schlagen, welche leichtentflammbare Dämpfe oder Materialien entzünden und somit zu Feuer und Explosionen führen können.

Benutzen Sie das Gerät nicht in ausgewiesenen Gefahrenzonen, wie etwa sauerstoffangereicherten Arbeitsumgebungen. Wenn Flammen oder Rauch auftreten, schalten Sie das Gerät unverzüglich ab, ziehen Sie den Netzstecker und kontaktieren Sie einen autorisierten Miltenyi Biotec Service Dienstleister oder den Miltenyi Biotec Technical Support.

Das Gehäuse des Geräts dient dazu, das Risiko eines elektrischen Stromschlags, eines Kurzschlusses oder von Feuer zu reduzieren. **Mit Ausnahme der vorderen Abdeckklappen, entfernen oder durchstechen Sie keine Abdeckungen des Gerätes oder von zusätzlicher Hardware, welche von Miltenyi Biotec bereitgestellt wird. Nur autorisiertes Personal darf jegliche andere Abdeckung des Instruments entfernen. Führen Sie nie einen Fremdkörper durch Öffnungen in das Gerät ein.**

Benutzen Sie das Gerät nicht, wenn

- es offen oder zerlegt ist
- es fallengelassen wurde oder beschädigt ist
- Teile beschädigt oder defekt sind
- die Netzanschlussleitung beschädigt ist
- ein Gegenstand in die Belüftungsschlitze eingedrungen ist
- ein Gegenstand in das Gerät gefallen ist

Das Gerät ist ausschließlich für den Betrieb in Innenräumen ausgelegt. Sollten Flüssigkeiten in das Gerät gelangen, kann es zu Kurzschluss, Stromschlag oder Feuer kommen. Seien Sie vorsichtig im Umgang mit Flüssigkeiten.

Lassen Sie keine Flüssigkeit in das Innere des Gerätes gelangen. Schützen Sie das Gerät vor verschütteten oder verspritzten Flüssigkeiten. Beseitigen Sie ausgetretene oder verschüttete Flüssigkeit sofort. Benutzen Sie das Gerät nicht, sollte Flüssigkeit in das Innere des Gerätes gelangt sein. Setzen Sie das Gerät nicht in einer nassen oder feuchten Umgebung ein. Vermeiden Sie Arbeitsumgebungen mit hoher Luftfeuchtigkeit oder Kondensation. Das Überführen des Gerätes von einer kalten Umgebung – z.B. aus einem Kühlraum bei 5°C – in einen Raum mit Raumtemperatur, kann zu Kondensation im Inneren des Gerätes führen. Warten Sie in solchen Fällen mit der Benutzung des Gerätes, bis es getrocknet ist.

Ziehen Sie den Netzstecker vor der Reinigung des Gerätes. Verwenden Sie keine Flüssig- oder Sprühreinigungsmittel, sondern nur ein feuchtes Tuch.

Schützen Sie das Gerät vor Überhitzung. Betreiben Sie das Gerät nicht in Umgebungen mit mehr als 25°C. Gewährleisten Sie während des Betriebs eine ausreichende Luftzirkulation im Raum. Ermöglichen Sie während des Betriebs ausreichende Luftzirkulation – mindestens 15 cm an allen Seiten – um das Gerät herum. **Das Gerät darf nicht in der Nähe von Radiatoren, Heißlüftern, Öfen, oder anderen Wärme**

erzeugenden Geräten aufgestellten (Verstärker eingeschlossen). Schützen Sie das Gerät vor direkter Sonneneinstrahlung. Verdecken Sie keine Schlitze und Öffnungen des Geräts, da diese der Belüftung dienen. Integrieren Sie das Gerät nicht in einen Einbauschränk oder ähnlich begrenzten Platz, es sei denn, es wurde speziell entwickelt, um ausreichende Belüftung zu gewährleisten. Befolgen Sie die Montageanleitung für den Aufbau des Gerätes.

Das Gerät ist mit einem Schutzkontaktstecker und einer dreiadrigen Anschlussleitung ausgestattet. Dieser Stecker passt nur in eine Steckdose mit Schutzkontakt. Dies ist eine Sicherheitsvorrichtung. **Versuchen Sie nicht, den Stecker in eine nicht geerdete Steckdose einzuführen.** Wenn Sie den Stecker nicht in die Steckdose einführen können, bitten Sie einen ortsansässigen Elektriker, diese zu ersetzen.

An die mit COM1 beschriftete RS-232-Buchse dürfen nur Peripheriegeräte angeschlossen werden, die UL 60950 erfüllen. An die mit External CAN beschrifteten Buchsen darf nur Originalzubehör des MACSQuant Instruments angeschlossen werden.

An die mit RS232/BCR beschriftete Buchse darf nur der mitgelieferte 2D-Barcodeleser angeschlossen werden. Externe Lasergeräte, die an die mit RS232/BCR beschriftete Buchse angeschlossen werden, müssen IEC 60825-1 erfüllen.



Starkes Magnetfeld

Das Instrument ist mit einem extrem starken Magneten ausgestattet. Es besteht die Gefahr von schweren Verletzungen für Personen mit Herzschrittmacher, Cerebralshunts oder elektronischen medizinischen Implantaten.



Personen mit Herzschrittmacher oder anderen elektronischen medizinischen Implantaten müssen Abstand halten. Halten Sie magnetische Speichermedien, elektronische Geräte und ferromagnetische Werkzeuge auf einem Abstand von mindestens 20 cm.



Mechanische Gefahr

Bewegliche und rotierende Teile sind potentielle mechanische Gefahrenquellen.

Öffnen Sie nicht die vorderen Abdeckklappen während das Gerät läuft. Behindern Sie nicht die Bewegung des Pipettierarms und der zugehörigen Komponenten während des Betriebs. Es besteht ein Risiko von Stichverletzungen und Quetschungen für Körperteile. Halten Sie Finger etc. von allen beweglichen Teilen des Instruments und allen zugehörigen Komponenten fern. Umgehen Sie keine Sicherheitsvorrichtungen.

Berühren oder verändern Sie nicht die Flüssigkeitspumpen und Schläuche während das Instrument läuft. Schalten Sie das Gerät immer aus, bevor Sie Arbeit am Flüssigkeitssystem vornehmen. Halten Sie laufende Prozesse immer an oder brechen Sie sie ab, bevor Sie Zubehör wie zum Beispiel den MACS MiniSampler Plus handhaben, oder Reagenzgläser in das Reagenzglasgestell stellen oder entnehmen. Betreiben Sie das Gerät nur mit Nadelschutz.

Optische Strahlungsgefährdung



Der MACSQuant® Instrument ist nach Norm IEC 60825-1 als Klasse 1M-Laserprodukt eingestuft. Der MACSQuant Instrument ist mit drei kontinuierlichen Lasern ausgestattet (Laser Klasse 3B). Diese Laser sind durch ein Schutzgehäuse gesichert. **Entfernen Sie das Schutzgehäuse nicht. Die Verwendung von anderen als hier genannten Bedienungselementen sowie die Anpassung oder Durchführung von anderen als hier genannten Verfahren kann gefährliche Strahlung freisetzen.**



Das Instrument ist mit vier oberflächenemittierenden Lasern mit vertikalem Resonator (VSCL) zur automatischen Reagenzglasgestell-Erkennung (Klasse 1M) ausgestattet. Die Strahlung ist nicht sichtbar.

Unsichtbare Laserstrahlung. Nicht direkt mit Teleskopoptiken betrachten.

Das Gerät ist auch mit einem 2D-Code-Leser ausgestattet sowie mit leistungsstarken Leuchtdioden (LEDs) zur Beleuchtung des Lesefeldes. Leistungsstarke LEDs werden auch dazu benutzt, Flüssigkeitsbehälter und den Abfallbehälter zu beleuchten. Gemäß der internationalen Norm IEC 62471 hat dieses Lampensystem einen Gefahrenwert der Exposition (EHV) von 0,91 und liegt außerhalb der Freien Gruppe.

Entfernen Sie die Flaschenkörbe nicht, es sei denn, Sie integrieren das Gerät in ein Pipettiersystem. Wenn die Flaschenkörbe entfernt wurden, stellen Sie sicher, dass der Nutzer nicht der LED-Strahlung ausgesetzt ist.

Schauen Sie weder direkt in die Laser- oder LED-Strahlung noch in eine durch eine Spiegelfläche reflektierte Laser- oder LED-Strahlung. Dies kann sonst zu Augenverletzungen führen. Richten Sie den Laserstrahl nicht auf andere.

Achten Sie auf den optischen Weg des Laserstrahls oder der Reflexion durch eine Spiegeloberfläche. Achten Sie bei der Einrichtung des Instruments darauf, dass sich der optische Weg des Laserstrahls beim Betrieb nicht auf gleicher Höhe mit dem menschlichen Auge befindet. Vermeiden Sie, dass Wasser, Öl, Staub oder andere Fremdkörper dem Öffnungsfenster des 2D-Code-Lesers anhaften. Dies kann zu Lesefehlern führen. Stellen Sie vor der Reinigung des Scanners sicher, dass keine Laserstrahlen mehr emittiert werden. Der Umgang mit dem Laser kann sonst zu Augenverletzungen führen. Verwenden Sie zum Abwischen von Substanzen auf dem Scanner ein weiches, trockenes Tuch. Verwenden Sie keinen Alkohol oder andere Reinigungssubstanzen.

Strahlung von demontierten Geräten kann zu Augenverletzungen führen. **Demontieren, wechseln oder entfernen Sie eingebaute Laser- oder LED-Strahlungsquellen nicht. Die Laser- und LED-Strahlungsquellen hören bei Demontage nicht automatisch auf, Strahlung zu emittieren.**

Der Gefährdungsabstand (HD) für die freie Gruppe beträgt 61 cm. Der Gefährdungsabstand für die Risikogruppe 1 beträgt 20 cm.

	Output power	Pulse time	Wavelength
MACSQuant Analyzer 10			
Gefäßhaltererkennung	3.3 mW	215 µs	850 nm
Interner Laser 1	30 mW	Dauerstrich	488 nm
Interner Laser 2	40 mW	Dauerstrich	404 nm
Interner Laser 3	21.5 mW	Dauerstrich	640 nm
MACSQuant VYB			
Gefäßhaltererkennung	3.3 mW	215 µs	850 nm
Interner Laser 1	100 mW	Dauerstrich	561 nm
Interner Laser 2	40 mW	Dauerstrich	404 nm
Interner Laser 3	50 mW	Dauerstrich	488 nm
MACSQuant Analyzer 16			
Gefäßhaltererkennung	3.3 mW	215 µs	850 nm
Interner Laser 1	50 mW	Dauerstrich	488nm
Interner Laser 2	65 mW	Dauerstrich	404 nm
Interner Laser 3	72 mW	Dauerstrich	642 nm

Table 3.1: Laserausgangsleistung, Impulszeit, und Wellenlänge.

Chemische und biologische Gefahren



Abhängig von dem benutzten biologischen Material kann eine Kontamination oder Infektion zu schweren Verletzungen oder Tod führen. Klinische Proben müssen als potentiell infektiös angesehen werden.

Wird oder wurde mit biologischen Gefahrstoffen gearbeitet, muss der Bediener des Gerätes entsprechend den für die verwendeten Substanzen geltenden Warnhinweisen und Schutzbestimmungen eine persönliche Schutzausrüstung tragen. Der oben genannte Sicherheitshinweis gilt auch für etwaige gefährliche Chemikalien, einschließlich toxischer oder korrosiver Chemikalien, ätzender oder radioaktiver Substanzen, die in der Probe anwesend sein können.

Tragen Sie Schutzhandschuhe, Schutzkleidung und Schutzbrille, um Berührung der Gefahrstoffe mit Haut und Augen zu vermeiden. Falls Gefahrstoffe verwendet wurden oder ausgetreten sind, muss auf eine sorgfältige Dekontamination des Gerätes geachtet werden. Es ist strengstens verboten, kontaminierte Geräteteile oder Zubehörteile weiter zu verwenden.

Schützen Sie auch Mund und Nase, da Aerosole aus dem System entweichen könnten. Mangelhafte oder unzureichende Schutzausrüstung ist gefährlich. Werden Gefahrstoffe oder unbekannte Substanzen eingesetzt, muss das Gerät unter einem Abzug oder einer Sicherheitswerkbank benutzt werden.

Alle flüssigen und festen Abfälle müssen als Gefahrstoffe angesehen werden, und die Handhabung der Abfälle muss daher unter Beachtung der allgemein geltenden Laborsicherheitsbestimmungen erfolgen. Die Entsorgung der Verbrauchsmaterialien muss gemäß den örtlichen Bestimmungen erfolgen.

Röhrchen und alle weiteren Verbrauchsmaterialien, die in Kontakt mit biologischen Gefahrstoffen gelangt sind, müssen vor dem Entsorgen dekontaminiert werden. Flüssigabfall muss autoklaviert oder unter Verwendung eines für das jeweilige spezifische Pathogen geeigneten Desinfektionsmittels dekontaminiert werden, z.B. 10% Bleichmittel, Isopropylalkohol oder 70% Ethanol.

Beschädigte Teile, die mit biologischen Gefahrstoffen in Kontakt waren, sind potentiell gefährlich.

Überprüfen Sie das fluidische System (das Schlauchsystem, Flaschen und deren Verschlüsse, Ventile, Säulen, Verdüner und Nadeln) vor Inbetriebnahme des Gerätes. Ersetzen Sie alle beschädigten Teile, falls Sie eine undichte Stelle bemerken. Können beschädigte Teile nicht ersetzt werden, ziehen Sie den Netzstecker und benutzen Sie das Gerät nicht.

Wartung und Transport

Falsche oder unsachgemäße Wartung oder Reparatur an Ihrem Gerät kann zur Gefährdung des Anwenders, unvorhersehbaren Resultaten, Fehlfunktionen, Geräteschäden, vorzeitigem Verschleiß und verringerter Lebensdauer führen. Es kann auch den Verlust Ihrer Garantieansprüche zur Folge haben.

Warten Sie das Gerät nicht selbst, es sei denn, es ist in diesem Benutzerhandbuch oder anderen technischen Unterlagen von Miltenyi Biotec ausdrücklich vermerkt. Wartung und Reparaturen müssen durch geschulte Fachkräfte ausgeführt werden.

Wenn ein Austausch oder Ersatzteile benötigt werden, stellen Sie sicher, dass Ihr Servicedienstleister nur Originalteile von Miltenyi Biotec oder Teile von Drittanbietern verwendet, die von Miltenyi Biotec spezifiziert und empfohlen werden. Die Verwendung unautorisierter Ersatzteile kann Fehlfunktionen des Gerätes verursachen und die Ergebnisse beeinträchtigen. Miltenyi Biotec akzeptiert keinerlei Garantieansprüche und haftet nicht für Fehlfunktionen oder Schäden am Gerät, die auf Verwendung ungeeigneter Verschleiß- oder Ersatzteile zurückzuführen sind. Stellen Sie sicher, dass nach jeder erfolgten Wartungs- oder Reparaturleistung ein autorisierter Miltenyi Biotec Servicedienstleister alle notwendigen Sicherheitsprüfungen, welche die durchgeführten Reparaturmaßnahmen verlangen, durchführt, um sicherzustellen, dass das Gerät sich in vorschriftsmäßigem Zustand befindet.

Nutzen Sie nur von Miltenyi Biotec empfohlenes Zusatzgerät und Upgrades zu Ihrem Gerät. Fragen Sie Ihren örtlichen Miltenyi Biotec Vertriebsmitarbeiter nach Miltenyi Biotecs weit reichenden Vereinbarungen zum Geräteservice und Technical Support oder besuchen unsere Website www.miltenyibiotec.com/support.

Das Gerät sollte vorsichtig gehandhabt und nur in der von Miltenyi Biotec bereit gestellten Verpackung transportiert werden. Im Gerät können innere Schäden auftreten, falls es großer Erschütterung ausgesetzt oder fallengelassen wird. Sollte wegen Reparatur- oder Wartungsleistungen ein Rücktransport zum Hersteller notwendig sein, dekontaminieren Sie das Gerät vor dem Versand, um jegliche Gefahrenstoffe zu entfernen. Sollten Sie Fragen zur vorschriftsmäßigen Dekontaminierung oder zum Versand des Gerätes haben, wenden Sie sich zur Unterstützung an unseren Miltenyi Biotec Technical Support.

Entsorgung



Kundeninformation zur Entsorgung von Elektro- und Elektronik-Altgeräten (Waste of Electrical and Electronic Equipment, WEEE)

Bitte entsorgen Sie Ihre Altgeräte von Miltenyi Biotec unter Einhaltung der jeweils geltenden Vorschriften für die Erfassung und Behandlung von Elektro- und Elektronik-Altgeräten und die Entsorgung von Gefahrstoffen.

Diese können von Land zu Land sowie regional variieren. Elektrische und elektronische Geräte können Gefahrstoffe enthalten, welche die Umwelt erheblich belasten und/oder die Gesundheit gefährden. Deshalb müssen Altgeräte speziell gesammelt und durch ausgewiesene Entsorgungsbetriebe im Rahmen der hierfür vorgesehenen Entsorgungssysteme fachgerecht behandelt werden. Indem Sie sicherstellen, dass Ihr Altgerät gemäß den geltenden Vorschriften zur Behandlung von Elektro- und Elektronik-Altgeräten sowie von Gefahrstoffen entsorgt wird, tragen Sie dazu bei, unsere natürlichen Ressourcen zu schonen und die menschliche Gesundheit zu schützen.

Miltenyi Biotec setzt sich für den Schutz der Umwelt ein. Miltenyi Biotec bietet in zahlreichen Ländern eigene Rücknahmeprogramme für Altgeräte an und arbeitet weltweit mit lizenzierten Partnern zusammen, die an bestehende Recycling- und Entsorgungssysteme angeschlossen sind. Miltenyi Biotec ermöglicht Ihnen ein kostenloses Recycling Ihres Altgerätes. Die Bedingungen und die Verfügbarkeit dieses Angebots unterscheiden sich geographisch aufgrund unterschiedlicher regulatorischer Anforderungen. Bitte beachten Sie, dass je nach Art und Nutzung Ihres Gerätes zusätzliche Anforderungen gelten können.

Für weitere Informationen oder wenn Sie Ihr Miltenyi Biotec-Altgerät entsorgen möchten, wenden Sie sich bitte an Ihren lokalen Miltenyi Biotec-Vertreter oder den Miltenyi Biotec Technical Support.

EN

DE

ES

FR

IT

Advertencias y precauciones

**WARNING**

El instrumento está diseñado para un uso seguro si se instala correctamente, y se maneja por personal cualificado de acuerdo con las prácticas generales de seguridad y las instrucciones de este manual de usuario.

Las directrices en esta sección explican los riesgos potenciales asociados con el manejo de este instrumento y proporcionan una importante información complementaria para minimizar los riesgos. Siga las instrucciones atentamente para protegerse a sí mismo, a otros y al equipamiento, de riesgos potenciales y crear un ambiente de trabajo seguro. Use este instrumento solo como especificado por el fabricante para evitar daños en el equipo y lesiones en el personal. Siga siempre las instrucciones de seguridad y política de laboratorio del área de trabajo local, así como los estándares de salud, seguridad y prevención de accidentes. Contacte la autoridad local a cargo de la fuente de energía eléctrica, construcciones, mantenimiento o seguridad para más información sobre la instalación segura y manejo del instrumento.

Niveles de riesgo

Se usan señales para identificar mensajes de seguridad y de daño de la propiedad. Las siguientes señales se usan a través de este manual de usuario.

**WARNING**











o **WARNING!** indica una situación potencialmente peligrosa, la cual, si no se evita, puede resultar en muerte o daños graves.

**CAUTION**

o **CAUTION!** indica una una situación potencialmente peligrosa, la cual, si no se evita, puede resultar en un daño menor o moderado. También puede ser usado para alertar contra prácticas peligrosas.

Símbolos de seguridad

Los siguientes símbolos se usan para destacar condiciones que podrían causar daños al personal o daños al equipo.

-  Alerta de seguridad. Riesgo de peligro. Es necesario consultar la documentación del equipo siempre que este símbolo de seguridad aparezca, para de esta manera poder averiguar la naturaleza del peligro potencial existente y las acciones necesarias a realizar.
-  Riesgo de shock eléctrico.
-  Campo magnético intenso.
-  Personas con marcapasos o implantes médicos electrónicos deben mantenerse alejadas.
-  Riesgo de que se aplaste o corte alguna parte del cuerpo.
-  Radiación óptica peligrosa.
-  Radiación láser peligrosa.
-  Riesgo biológico. Riesgo de contaminación si se usa material biológico potencialmente peligroso.
-  Bloques de conexión para conductores de protección. El símbolo está pegado en el interior del instrumento. Esta información es para el personal de servicio.
-  On (Fuente de energía).
OFF (Fuente de energía).

Etiqueta de seguridad

Por favor tenga en cuenta los puntos de peligro y los símbolos de seguridad del instrumento. Las etiquetas de seguridad arriba mencionadas y las marcas de seguridad deberán mantenerse limpias y legibles. Inspeccionar periódicamente las etiquetas y marcas de seguridad y reemplazarlas en caso de que estas no sean legibles o perceptibles a una distancia visual segura. Contacte con Miltenyi Biotec para reemplazo de etiquetas.

Etiqueta de seguridad en el instrumento

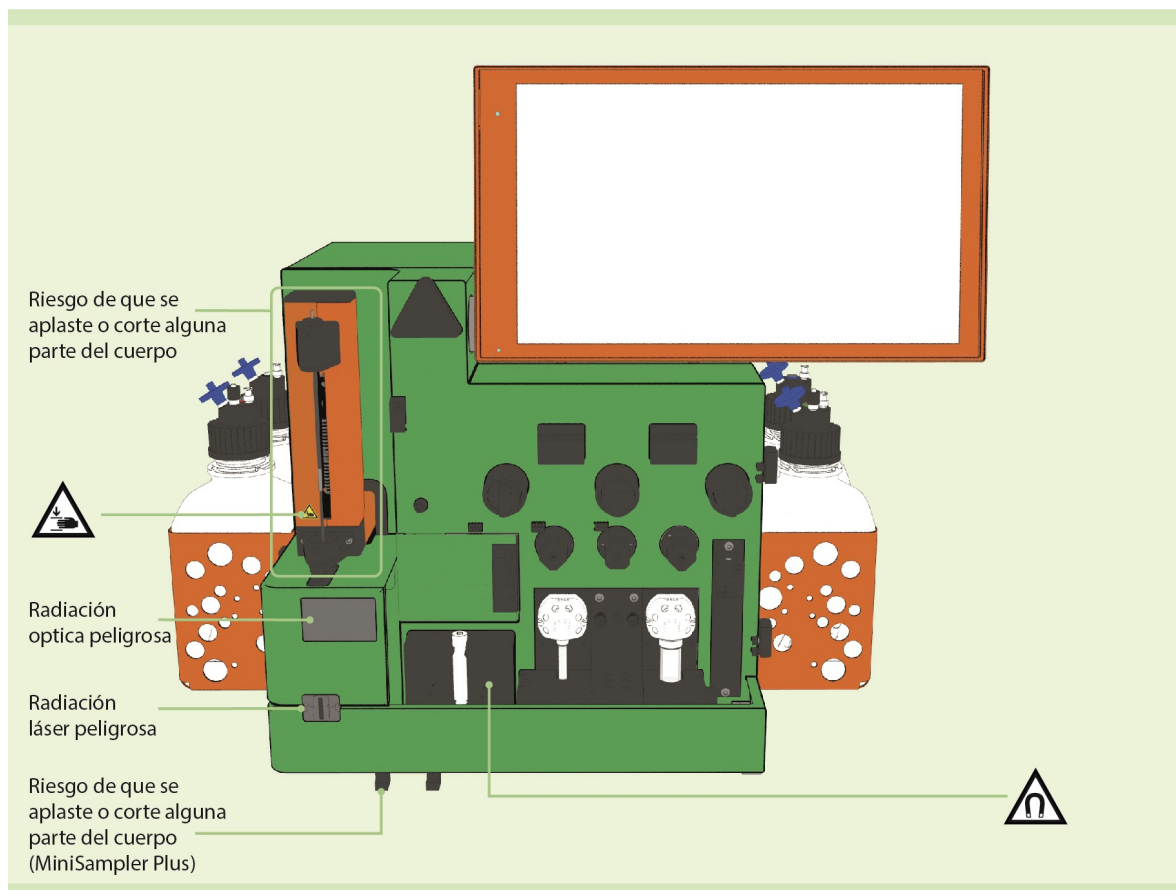

Figure 1: Puntos de peligro de y localización de los símbolos de seguridad que puede encontrar en la parte delantera del MACSQuant® Instrument.

EN

DE

ES

FR

IT

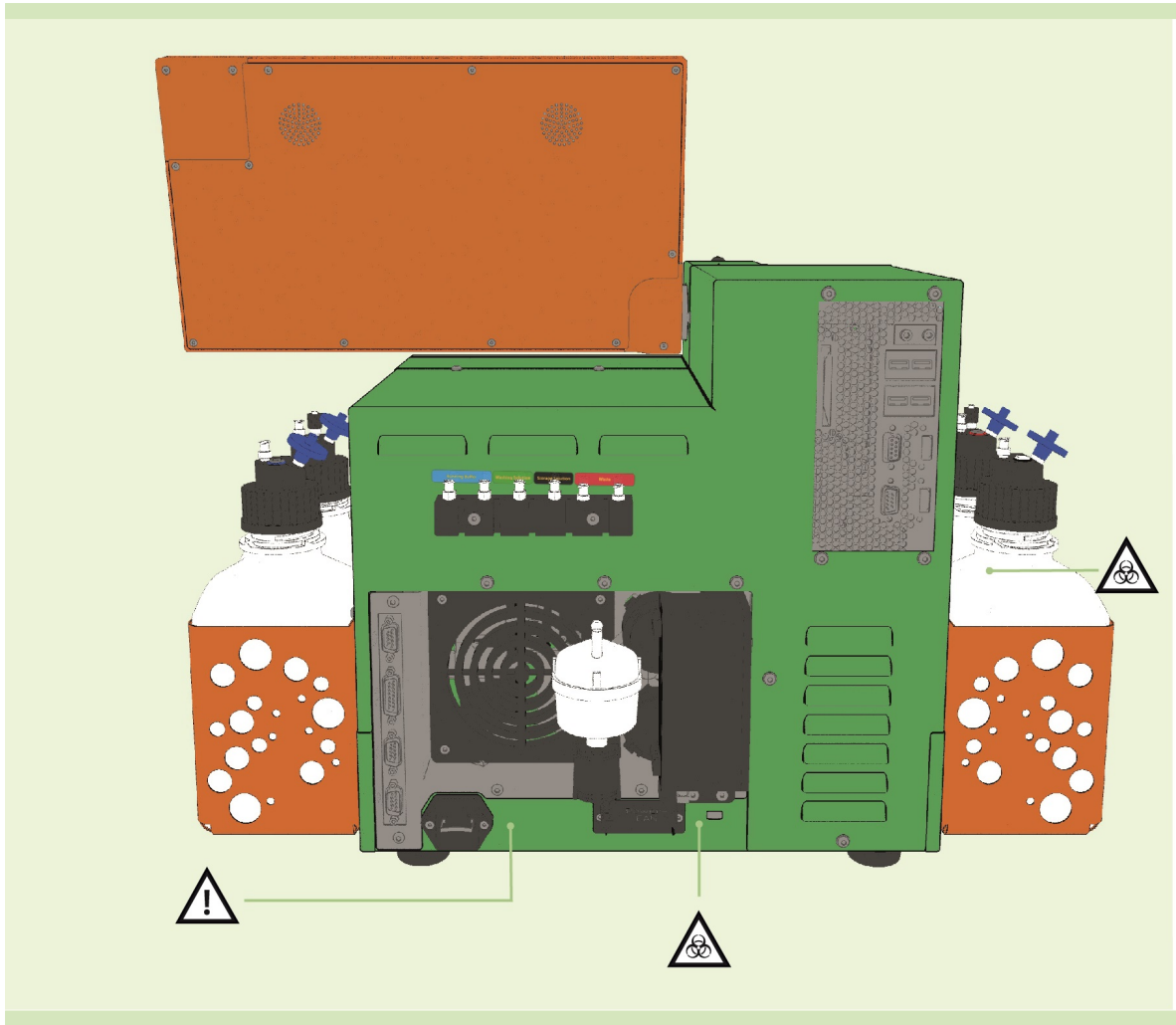

Figure 2: Localización de los símbolos de seguridad en la parte trasera del MACSQuant® Instrument.

Instrucciones generales de seguridad



Si el instrumento no funciona correctamente y / o las instrucciones o mensajes mostrados le aconsejan contactar con el servicio técnico, no es posible utilizar el instrumento de una manera segura. Apague y desenchufe inmediatamente el instrumento de la toma de corriente, y contacte un proveedor de servicios autorizado de Miltenyi Biotec o un servicio técnico autorizado.

Incendios y riesgos eléctricos



Los riesgos potenciales causados por aparatos eléctricos incluyen shock eléctrico, cortocircuito y sobrecalentamiento. Un shock eléctrico puede llevar a graves daños corporales o incluso la muerte.

Para asegurarse de cumplir con la normativa electromagnética vigente, conecte los dispositivos periféricos únicamente usando cables doblemente cubiertos; utilice sólo el cable de corriente y el teclado incluidos en la entrega del equipo. Utilice exclusivamente cables de conexión con un largo menor a 3 m. El teclado sólo debe ser usado con los MACSQuant® Instrument.

Asegúrese de que el enchufe principal así como el conector para el cable de energía están fácilmente accibles y colocados tan cerca del operador del instrumento como sea posible. Si es necesario desconectar la fuente de energía, desconecte el cable de la toma de corriente.

El instrumento debería ser utilizado desde una fuente de energía que cumple las especificaciones mencionadas en la etiqueta de potencia eléctrica del producto. Si tiene preguntas sobre el tipo de fuente de energía que usar, contacte a su proveedor de servicios autorizado de Miltenyi Biotec o una compañía de energía local.

No use alargadores o enchufes múltiples. No sobrecargue una toma de corriente.

Un cortocircuito eléctrico o sobrecalentamiento puede ser causa de incendio. El equipo electrónico puede emitir chispas, las cuales podrían encender vapores o material combustible resultando en explosión o incendio.

No use el instrumento en áreas designadas como peligrosas; por ejemplo, en medios cargados de oxígeno. Si aparecen llamas o humo, inmediatamente apague la fuente de energía, desenchufe el instrumento de la toma de corriente, y contacte un proveedor de servicios autorizado de Miltenyi Biotec o un servicio técnico de Miltenyi Biotec.

La caja protectora del instrumento está diseñada para reducir el riesgo de shock eléctrico, cortocircuito eléctrico y propagación de fuego. **Excepto por el acceso frontal, no quite o penetre ninguna tapa o cubierta, ni ninguna cubiertas de otro hardware accesorio suministrado por Miltenyi Biotec. Solo el personal autorizado debe quitar las otras tapas del instrumento. Nunca introduzca un objeto extraño a través de una apertura en el instrumento.**

No use el instrumento si

- se ha abierto o desensamblado
- se ha caído o ha sido dañado
- tiene partes dañadas o rotas
- tiene un cable de energía dañado
- un objeto ha entrado a través de las ranuras de ventilación
- un objeto extraño ha caído en el instrumento

El instrumento está destinado solo a uso en un lugar cubierto. Si algún fluido entra en el instrumento, puede ocasionar cortocircuitos eléctricos, shock eléctrico o incendio. Tenga cuidado al manipular líquidos.

No permita que líquidos penetren el interior del instrumento. Proteja el instrumento contra vertidos y salpicaduras accidentales. Limpie inmediatamente los vertidos. No utilice el instrumento si se han derramado líquidos en el instrumento. No use el instrumento en un lugar mojado o húmedo. Evite áreas con alta humedad o vapor. Transportar el instrumento de un medio fría – como una habitación fría a 5°C – a temperatura ambiente, puede causar una condensación dentro del instrumento. En esos casos, espere a que el instrumento se deshumidifique antes de utilizarlo.

Desenchufe el instrumento de la toma de corriente antes de limpiarlo. No utilice agentes limpiadores líquidos o aerosoles; use siempre un paño húmedo.

Proteger el instrumento contra el sobrecalentamiento. No utilice el instrumento en lugares con más de 25° C. Asegúrese de que hay suficiente ventilación en el lugar donde se utilice el instrumento. Deje suficiente espacio libre alrededor del dispositivo - por lo menos 15 cm en todos los lados - durante la operación.

No coloque el instrumento cerca de radiadores, registros de calor, estufas u otro equipamiento (incluyendo amplificadores) que genere calor. Proteja el instrumento de la luz solar directa. No cubra las ranuras y aperturas del instrumento ya que están destinadas a la ventilación. No

EN

DE

ES

FR

IT

coloque le instrumento en un estante empotrado o espacios similarmente confinados a menos que el espacio haya sido específicamente designado para proveer una ventilación adecuada. Siga las instrucciones de montaje del instrumento.

El instrumento está equipado con un enchufe eléctrico con tres cables para la toma de tierra, que tiene una tercera clavija para la toma. Este enchufe solo se adapta a una toma de corriente de tierra. Este es un procedimiento de seguridad. **No intente insertar el enchufe en una toma de corriente que no sea de tierra.** Si no puede insertar el enchufe en la toma, contacte a su electricista local para reemplazar la toma.

Only peripheral devices that comply to UL 60950 are allowed to be connected to the RS232 connector labeled COM1. Adicionalmente deben conectarse exclusivamente equipos originales de MACSQuant Instruments con los conectores rotulados con External CAN.

Solo el lector de códigos de barra 2D que se entrega con el instrumento es el que se puede conectar en el conector RS232/BCR. Los dispositivos de láser externos conectados con el conector rotulado con RS232/BCR deben cumplir con la norma IEC 60825-1.

Campo magnético intenso



El instrumento está equipado con un imán extremadamente potente. Existe un riesgo de lesión grave para las personas que llevan marcapasos, derivaciones cerebrales o implantes médicos electrónicos.



Las personas que llevan marcapasos e implantes médicos electrónicos deben mantenerse una distancia de al menos 20 cm. Mantenga todos los dispositivos de almacenamiento magnético, equipos electrónicos y objetos magnetizables a una distancia de al menos 20 cm.



Riesgos mecánicos

Mover y quitar piezas son potenciales riesgos mecánicos.

No abrir las cubiertas de acceso frontal durante el servicio del dispositivo. No obstruir el movimiento del brazo automatizado y de los accesorios durante la operación. Existe riesgo de perforar, de aplastamiento y cortado partes del cuerpo. Manter los dedos etc. lejos de todas las piezas móviles del instrumento y loos accesorios. No omitir ninguna de las medidas o los dispositivos de seguridad.

No tocar las bombas de fluido ni ajustar la tubería durante la operación del dispositivo. Desactivar siempre el dispositivo antes de ajustar cualquier parte del sistema de fluidos. El procedimiento debe pararse o interrumpirse antes de maniobrar los accesorios, p. ej. el MACS MiniSampler Plus, o antes de de colocar o retirar los tubos del sopote de tubo colocado. Opere el equipo solo con la protección de la aguja incluida.

Riesgos de radiación óptica



El MACSQuant® Instrument está clasificado como producto láser 1M de estándar IEC 60825-1. El MACSQuant Instrument está equipado con tres láseres de corriente continua (láser clase 3B). Estos láseres son seguros dentro de una carcasa protectora. **No quite esta carcasa protectora en ningún momento. El uso de controles, el ajuste o la realización de procedimientos con excepción de los aquí especificados puede dar lugar a una peligrosa exposición de radiación.**



El dispositivo está equipado de cuatro unidades láser de emisión superficial de cavidad vertical (VCSEL) para la detección automatizada de reactivos (clase 1M). La radiación no es visible.

Radiación laser invisible. ¡No mirar directamente con ópticas telescópicas!

No mire directamente en el puerto VCSEL con instrumentos ópticos, por ejemplo, lupas. Puede ser peligroso para el ojo mirar el puerto VCSEL.

El dispositivo está equipado de un lector de código 2D y diodos electroluminosos de gran alcance (LED) para iluminar el área de la lectura. LEDs de gran alcance también se utilizan para iluminar las botellas de fluidos, así como la botella de desechos. De acuerdo con la normativa internacional IEC 62471, este sistema de lámpada tiene un valor de riesgo por exposición (EHV) de 0.91 siendo en exceso para el grupo exento de riesgos (Exempt Risk Group).

No quite esta carcasa protectora en ningún momento.

No extraiga las cestas de las botellas a menos que se integra el instrumento en un sistema de manejo de líquidos. Si se eliminan las cestas de botellas, garantizar que los usuarios no están expuestos a la radiación emitida LED.

No mirar directamente el láser, radiación LED, láser reflejado o radiación del LED de una superficie reflejada. De otra manera, podría ocasionarse una lesión ocular. No dirigir el rayo láser a otras personas.

Tener cuidado con la trayectoria del rayo o la reflexión láser de una superficie reflejada. Durante la instalación del instrumento, tener cuidado de que durante la operación la trayectoria del rayo láser no está a la misma altura que el ojo humano. No permitir que agua, aceite, polvo u otras sustancias ajenas se peguen a la ventana para la emisión del láser antes de limpiar el escáner. Esto puede causar errores de lectura. Asegúrese de parar la emisión del láser antes de limpiar el escáner. De no ser así, la exposición al láser puede ocasionar lesiones oculares. Utilizar un paño suave y seco para limpiar cualquier sustancia del escáner. No utilizar alcohol u otra sustancia de limpieza.

La radiación de unidades desmontadas puede ocasionar lesiones oculares. **No desmontar, modificar ni quitar el láser o la fuente de radiación LED o sus sopores de montaje. El láser o la fuente de radiación LED no interrumpen la emisión cuando están desmontados.**

La distancia de riesgo (HD) para el grupo exento de riesgos es de 61 cm. La distancia de riesgo para el Grupo de Riesgo 1 (Risk Group 1) es de 20 cm.

EN

DE

ES

FR

IT

	Potencia del láser	Duración del impulso	Longitud de onda
MACSQuant Analyzer 10			
Detección del rack de reactivos	3.3 mW	215 µs	850 nm
Láser interno 1	30 mW	continuo	488 nm
Láser interno 2	21.5 mW	continuo	404 nm
Internal Laser 3	40 mW	continuo	640 nm
MACSQuant VYB			
Detección del rack de reactivos	3.3 mW	215 µs	850 nm
Láser interno 1	50 mW	continuo	488 nm
Láser interno 2	40 mW	continuo	404 nm
Láser interno 3	100 mW	continuo	561 nm
MACSQuant Analyzer 16			
Detección del rack de reactivos	3.3 mW	215 µs	850 nm
Láser interno 1	50 mW	continuo	488 nm
Láser interno 2	65 mW	continuo	404 nm
Láser interno 3	72 mW	continuo	642 nm

Table 4.1: Potencia del láser, duración de impulso, y longitud de onda.

Riesgos químicos y biológicos



Dependiendo del material biológico utilizado, una contaminación o infección puede llevar a graves daños personales o muerte. Todas las muestras clínicas deben ser consideradas potencialmente infecciosas.

Si se ha usado material de riesgo biológico, el operador debe elegir y llevar puesto equipamiento personal de seguridad como indicado en las advertencias y precauciones para la sustancia particular. La precaución de seguridad anterior también es válida para cualquier químico de riesgo, incluyendo químicos tóxicos, o corrosivos, ácidos, o sustancias radioactivas que pueden estar presentes en la muestra.

Lleve guantes, ropa y gafas de seguridad para prevenir el contacto de la sustancia con la piel y ojos. Un equipamiento de seguridad defectuoso o inadecuado es peligroso. Si se ha utilizado o derramado material peligroso, debe tenerse cuidado en decontaminar a fondo el instrumento. Está estrictamente prohibido continuar utilizando accesorios o piezas del instrumento contaminadas.

También proteja la boca y la nariz pues los aerosoles podrían escaparse del sistema. El instrumento debe ser utilizado con una cubierta de seguridad si están siendo procesados materiales peligrosos o desconocidos.

Todos los residuos líquidos o sólidos deben ser considerados peligrosos de acuerdo con las precauciones universales de laboratorio. El desecho de residuos debe hacerse de acuerdo con las regulaciones locales.

Los tubos y otros consumibles que han estado en contacto con material de riesgo biológico deben ser descontaminados antes de su eliminación. Los residuos líquidos deberán ser autoclavados o descontaminados usando un desinfectante industrial apropiado para el patógeno específico, por ejemplo, hipoclorito de sodio al 10% alcohol isopropílico o etanol al 70%.

La falta de piezas por donde pasa material de riesgo biológico o el contacto con líquidos que han estado en dichas piezas podría ser peligroso.

Antes de encender el instrumento siempre inspeccione todo el sistema de fluidos (todas las conexiones y tubos, válvulas, columnas, jeringas y agujas). Si detectase alguna rotura o fuga, sustituya todas las piezas dañada antes de encender el instrumento. Si alguna parte dañada no puede ser sustituida, desconecte y no use el equipo.

Servicio y transporte

Una reparación o revisión inadecuada o incorrecta del instrumento puede causar riesgos a los usuarios, llevar a resultados impredecibles, causar el mal funcionamiento o daño del instrumento, así como un prematuro desgaste y vida reducida del instrument. También puede invalidar su garantía.

A menos que de otro modo señalado en este manual de usuario o en otra documentación de Miltenyi Biotec, no repare o revise el instrumento Usted mismo. Las revisiones y reparaciones deben ser llevadas a cabo por personal de servicio cualificado.

Cuando sean requeridas piezas de repuesto, asegúrese de que el proveedor de servicios usa solo piezas originales de Miltenyi Biotec, o piezas de terceros especificadas y recomendadas por Miltenyi Biotec. El uso de piezas no autorizadas puede causar un mal funcionamiento del instrumento y resultados dañados. Miltenyi Biotec no se hace responsable de ninguna garantía o de un error o daño del instrumento resultante del uso de piezas inadecuadas. Al finalizar cualquier servicio o reparación, asegúrese de que su proveedor de servicios autorizado de Miltenyi Biotec lleva a cabo todas las comprobaciones de seguridad como requerido por el procedimiento de reparación, para asegurarse de que el instrumento está funcionando correctamente.

Utilice solo opciones y actualizaciones recomendadas por Miltenyi Biotec. Consulte con su representante local de Miltenyi Biotec sobre el amplio servicio del instrumento, o diríjase a www.miltenyibiotec.com/support.

El instrumento debe ser transportado cuidadosamente en embalaje especificado por Miltenyi Biotec. Si el instrumento está sujeto a una vibración excesiva o caída, pueden ocurrir daños internos. Si el instrumento necesita ser enviado vuelta al fabricante para su servio, descontamine el instrumento para eliminar cualquier material peligroso antes del transporte. Si tiene preguntas respecto a una correcto descontaminación o transporte, contacte al Servicio Técnico Miltenyi Biotec.

Eliminación



Información sobre la Directiva de Residuos de Aparatos Eléctricos y Electrónicos (Waste of Electrical and Electronic Equipment, WEEE)

Por favor, al final de la vida útil de su equipo de Miltenyi Biotec disponga del mismo de acuerdo a la ley WEEE aplicable, la cual puede ser diferente según al país o región.

Los equipos eléctricos y electrónicos pueden contener sustancias peligrosas que pueden tener graves efectos perjudiciales sobre el medio ambiente y/o la salud humana. Por este motivo, todos los equipos deben ser específicamente reconocidos y tratados por los centros de residuos designados y según planes de cumplimiento de la WEEE cualificada. Al asegurarse de que se está deshaciendo de su equipo eléctrico y electrónico no deseado de acuerdo con la legislación y la WEEE aplicable de disposición de residuos peligrosos, estará ayudando a preservar nuestros recursos naturales y a proteger la salud humana.

EN

DE

ES

FR

IT

Miltenyi Biotec está comprometido con la protección del medio ambiente. Miltenyi Biotec ofrece productos que se encuentran en el final de su vida a programas de retorno de muchos países, y a socios con esquemas de cumplimiento de licencias WEEE en todo el mundo. Miltenyi Biotec le ofrece reciclar su equipo de Miltenyi Biotec en el final de su vida útil forma gratuita. Los términos y la disponibilidad de esta oferta pueden variar según la región geográfica, debido a las diferencias en los requisitos reglamentarios. Tenga en cuenta que, dependiendo del tipo y uso del equipo, pueden aplicarse requisitos adicionales.

Para más información, o si desea eliminar su equipo de Miltenyi Biotec en el final de su vida útil, por favor póngase en contacto con su representante local de Miltenyi Biotec o con el Servicio Técnico de Miltenyi Biotec.

IT	FR	ES	DE	EN
----	----	----	----	----

Avertissements et précautions



WARNING L'instrument est conçu pour une utilisation sûre, si il est correctement installé et manié par un personnel qualifié, conformément aux mesures de sécurité générales et aux consignes libellées dans ce manuel.

Les directives dans ce chapitre décrivent les risques potentiels associés au maniement de cet appareil et fournissent d'importantes informations de sécurité supplémentaires pour réduire les risques. Suivez soigneusement les instructions, afin de vous protéger vous-même, des tiers et le dispositif d'éventuels dangers et de créer un environnement de travail sûr. Utilisez cet appareil uniquement en respectant les instructions du fabricant afin d'éviter une détérioration du dispositif et des blessures du personnel. Suivez toujours les consignes de sécurité du champ d'opération et les bonnes pratiques de laboratoire ainsi que les normes pour la santé, la sécurité et la prévention d'accidents. Contactez les autorités locales gérant l'alimentation en courant électrique, la construction de bâtiments, la maintenance ou la sécurité pour plus d'informations sur l'installation et l'utilisation sûre de l'appareil.

Niveaux de danger

Des mots clé sont utilisés pour identifier des messages sur des détériorations matériels et de sécurité. Les mots clé suivants sont utilisés dans ce manuel.













ou **WARNING!** indique une situation potentiellement dangereuse, pouvant entraîner la mort ou des blessures graves, si elle n'est pas évitée.



ou **CAUTION!** indique une situation potentiellement dangereuse pouvant causer des blessures mineures ou modérées, si elle n'est pas évitée. Il peut également servir d'alerte contre une utilisation risquée.

Symboles de sécurité parties du corps

Les symboles suivants sont utilisés pour souligner des conditions qui pourraient entraîner des blessures du personnel ou une détérioration du dispositif.

-  Alerte de sécurité. Risque de danger. La documentation doit être consultée dans les cas où un symbole d'alerte de sécurité est mentionné afin de connaître la nature du danger potentiel et les mesures à prendre.
-  Risque d'un choc électrique.
-  Champ magnétique puissant.
-  Les personnes qui portent un stimulateur cardiaque ou un implant médical électronique doivent maintenir une distance de sécurité.
-  Risque d'écrasement et de cisaillement parties du corps.
-  Radiation optique dangereuse.
-  Radiation laser dangereuse.
-  Danger biologique. Risque de contamination, si des matières biologiques potentiellement dangereuses sont utilisés.
-  Borne pour conducteur de protection. Ce symbole est fixé à l'intérieur de l'appareil. Cette information est destinée au personnel de service.
-  On (Alimentation électrique).
Off (Alimentation électrique).

Étiquette de sécurité

S'il vous plaît identifier les zones de risque et les symboles de sécurité sur l'instrument. Les étiquettes et marquage de sécurité doivent être maintenus propres et lisibles. Il convient de les inspecter périodiquement et de les remplacer si elles ne sont pas lisibles ou perceptibles à une distance d'observation garantissant la sécurité du manipulateur. Contactez Miltenyi Biotec pour le remplacement des étiquettes de sécurité.

Étiquette de sécurité sur l'instrument

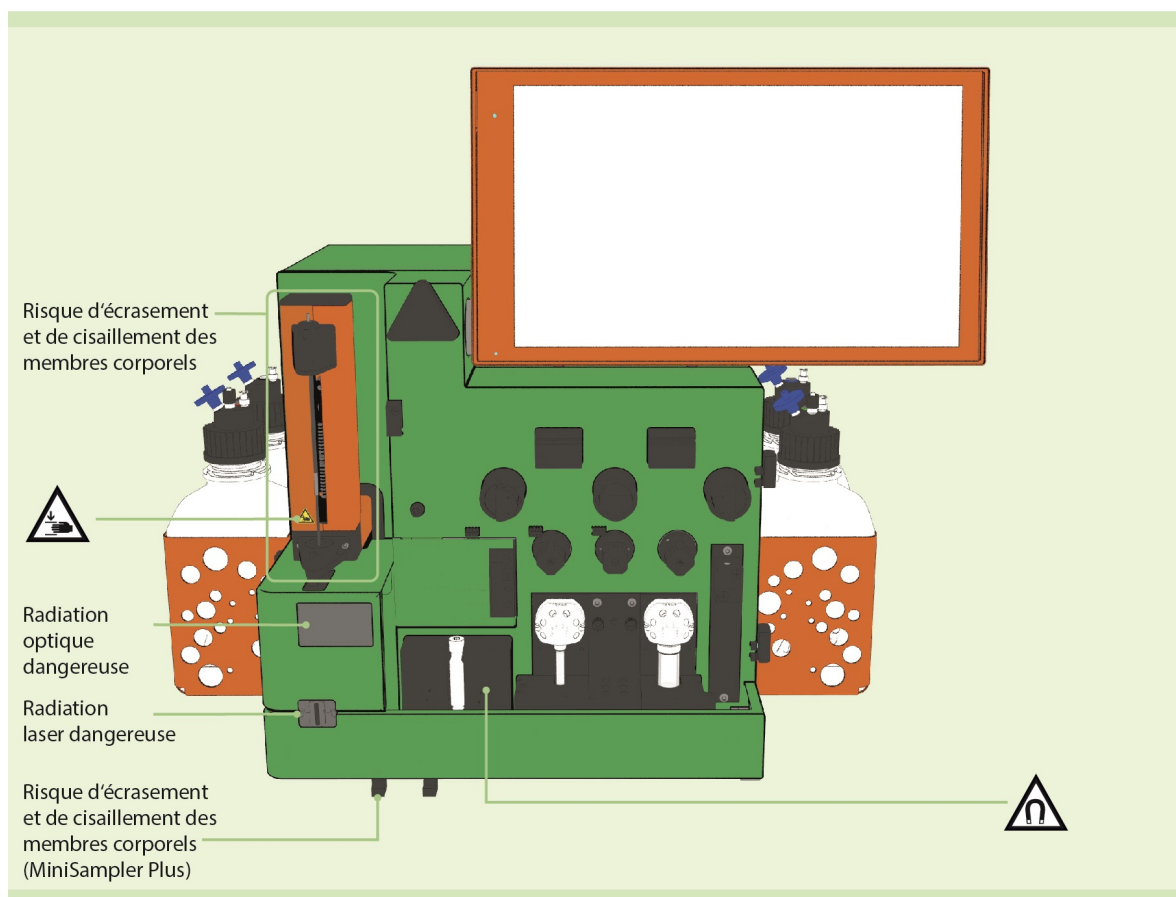

Figure 1: Les zones de risque et symboles de sécurité sur la face avant du MACSQuant® Instrument.

EN

DE

ES

FR

IT

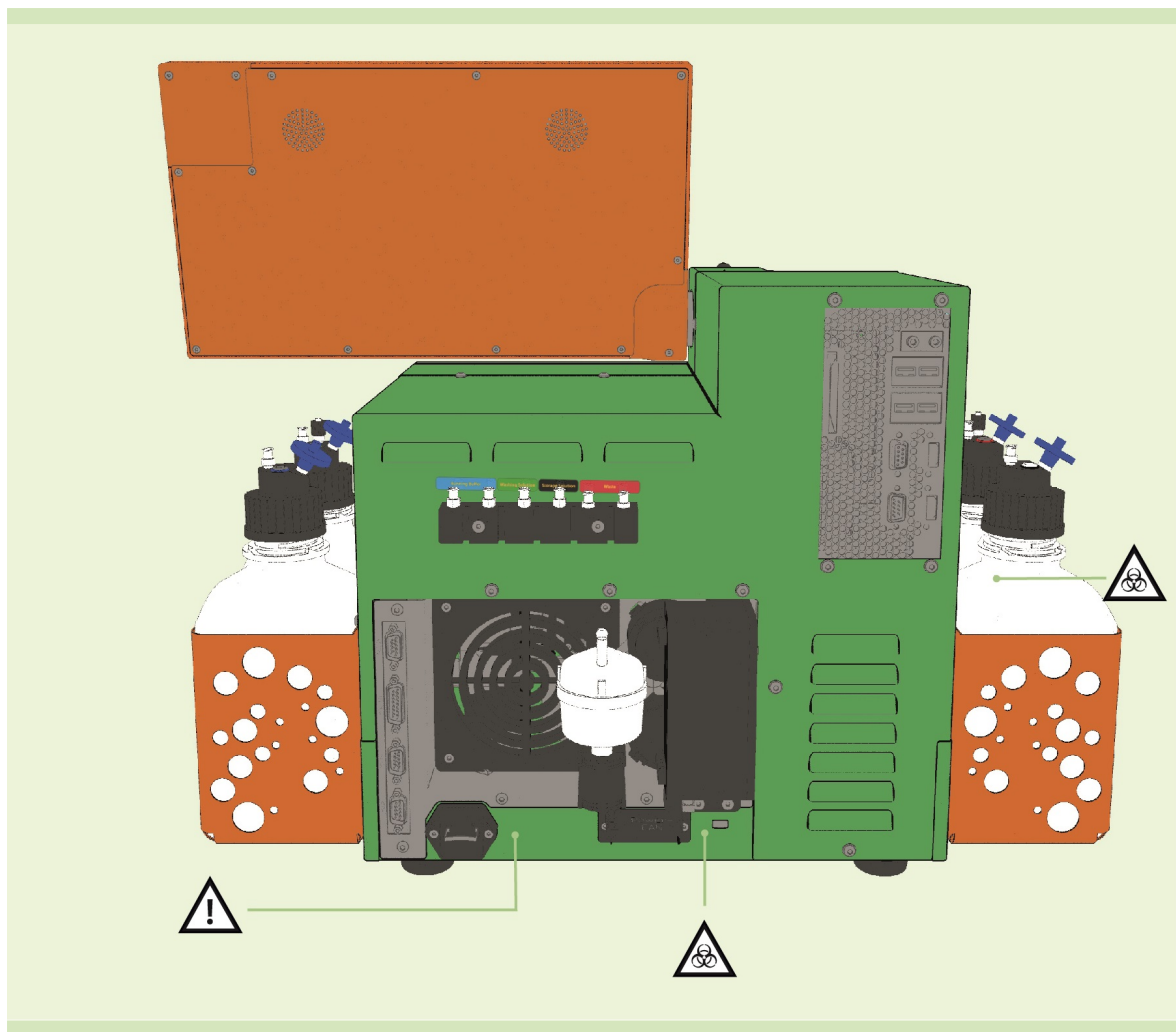

Figure 2: Les zones de risque et symboles de sécurité sur la face arrière du MACSQuant® Instrument.

Consignes de sécurité générales



Si l'appareil ne fonctionne pas correctement et/ou les instructions ou messages affichés vous avisent de contacter le support technique, l'utilisation sûre de l'appareil n'est plus longtemps garantie. Éteignez immédiatement l'appareil et débranchez-le de la prise électrique, puis contactez un prestataire de services Miltenyi Biotec agréé ou l'équipe de support technique de Miltenyi Biotec.

Dangers électriques et incendie



Les risques potentiels résultant d'appareils électriques sont le choc électrique, le court circuit et la surchauffe. Un choc électrique peut entraîner de graves blessures corporelles ou même la mort.

Afin de garantir la conformité électromagnétique, connecter les périphériques des appareils uniquement avec des câbles à double blindage et utiliser les câbles d'alimentation et le clavier fournis à la livraison. Utiliser exclusivement des câbles de connexion d'une longueur de moins de 3 m. Le clavier doit être utilisé uniquement avec le MACSQuant® Instrument.

Assurez que l'interrupteur général ainsi que le connecteur pour le câble électrique soient facilement accessibles et qu'ils se trouvent le plus proche possible de l'opérateur de l'appareil. S'il est nécessaire de couper l'alimentation électrique, débranchez le câble de la prise électrique.

L'appareil doit uniquement être utilisé à partir d'une source d'énergie qui remplit les spécifications mentionnées sur l'étiquette de puissance électrique du produit. Si vous avez des questions sur le type de source de courant à utiliser, contactez votre prestataire de services Miltenyi Biotec agréé ou votre entreprise locale de production et de distribution d'énergie.

N'utilisez aucune rallonge électrique ou multiprise. Ne surchargez pas une prise électrique.

Un court circuit ou une surchauffe peuvent provoquer un incendie. Des équipements électriques peuvent émettre des étincelles, pouvant enflammer des vapeurs ou matières combustibles, ce qui pourrait engendrer une explosion ou un incendie.

N'utilisez pas cet appareil dans des endroits jugés dangereux; par exemple, dans un environnement riche en oxygène. Si des flammes ou la fumée apparaissent, coupez immédiatement l'alimentation électrique, débranchez l'appareil de la prise électrique, puis contactez un prestataire de services Miltenyi Biotec agréé ou l'équipe de support technique de Miltenyi Biotec.

Le boîtier de l'appareil est conçu de façon à réduire les risques de choc électrique, de court circuit et de propagation du feu. **Sauf pour l'accès frontal couvre, n'enlevez aucun couvercle et n'y pénétrez pas, ni d'autres équipements accessoires fournis par Miltenyi Biotec. Seul un personnel autorisé a le droit d'enlever les autres couvercles de l'appareil. N'introduisez jamais un corps étrangers à travers d'une fente à l'intérieure de l'appareil.**

N'utilisez jamais l'appareil lorsqu'

- il est ouvert ou démonté
- il est tombé ou qu'il a été endommagé
- il a des pièces endommagées ou abîmées
- il a des câbles électriques endommagés
- un objet y est entré par les fentes de ventilation
- un corps étranger a pénétré dans l'appareil

L'appareil est uniquement destiné à une utilisation intérieure. Si des fluides pénètrent à l'intérieur de l'appareil, ceci peut entraîner des courts circuits, des chocs électriques ou des incendies. Faites extrêmement attention lorsque vous utilisez des liquides.

Veillez à ce qu'aucun fluide ne pénètre à l'intérieur de l'appareil. Protégez l'appareil contre des déversements et éclaboussures accidentels. Nettoyez immédiatement tout déversement. Ne pas utiliser l'appareil, si des liquides ont coulés dans l'appareil. Ne pas utiliser l'appareil dans des endroits humides et brumeux. Évitez des endroits ayant une forte humidité ou condensation. Le déplacement de l'appareil d'un environnement froid – comme une chambre froide à 5 °C – à un endroit à température ambiante peut causer une condensation à l'intérieur de l'appareil. Dans ces cas-là, attendez que l'appareil soit sec, avant de l'utiliser.

Débranchez l'appareil de la prise électrique avant de le nettoyer. Ne pas utiliser des détergents liquides ou aérosols; utilisez toujours un tissu humide.

Protéger l'instrument contre la surchauffe. Ne pas utiliser l'appareil dans des zones avec plus de 25°C. Assurer une circulation d'air suffisante dans la pièce quand l'instrument est utilisé. Prévoyez une circulation d'air suffisante autour de l'instrument – au moins 15 cm de tous les côtés – pendant le fonctionnement. **Ne pas**

EN

DE

ES

FR

IT

placer l'instrument à proximité des radiateurs, registres de chaleur, poêles ou autres appareils (y compris les amplificateurs) qui génèrent de la chaleur. Ne pas exposer l'appareil au soleil. Ne couvrez pas les fentes et les lumières de l'appareil, car elles servent de ventilation. Ne placez pas l'appareil dans un rack encastré ou des espaces confinés similaires, à moins que cet espace ait spécialement été conçu, pour fournir une ventilation convenable. Suivez les instructions de montage de cet appareil.

L'appareil est équipé d'une prise électrique à trois fils et mise à la terre avec une troisième broche de connecteur pour la mise à la terre. Cette prise ne s'emboîte que dans une prise de courant mise à la terre. ceci pour des raisons de sécurité. **N'essayez pas d'introduire la prise dans une prise femelle de courant non mise à la terre.** Si vous ne parvenez pas à introduire la prise dans une prise femelle, contactez votre électricien local pour remplacer la prise femelle.

Seuls les appareils périphériques conformes à la norme UL 60950 peuvent être branchés au connecteur RS232 étiqueté COM1. De plus, seuls des appareils MACSQuant Instrument originaux doivent être raccordés aux connecteurs étiquetés External CAN.

Seul un lecteur de code 2D recommandé par Miltenyi Biotec peut être branché au connecteur RS232/BCR. Les appareils laser externes raccordés au connecteur étiqueté RS232/BCR doivent répondre à la norme IEC 60825-1.



Champ magnétique puissant

L'instrument est équipé d'un aimant extrêmement puissant. Il ya un risque d'accident pour les personnels qui portent un stimulateur cardiaque, une dérivation cérébrale ou un implant medical électronique.



Les personnes qui portent un stimulateur cardiaque ou un implant medical électronique doivent maintenir une distance de sécurité. Veillez à laisser un espace d'au moins 20 cm entre le cache de l'aimant et les supports d'information magnétiques ainsi que l'équipement électronique.



Des pièces mobiles et tournantes sont de potentiels dangers mécaniques.

N'ouvrez pas les capots frontaux pendant le fonctionnement de l'appareil. Ne bloquez pas le mouvement du bras automatique ni des pièces correspondantes pendant le fonctionnement. Il ya un risque de perforation, écrasement et de cisaillement parties du corps. N'approchez pas vos doigts de toutes le pièces mobiles de l'instrument et des pièces correspondantes. Ne bloquez pas les dispositifs de sécurité et respectez les mesures de sécurité.

Ne touchez pas les pompes à liquide et ne modifiez pas les tuyaux pendant le fonctionnement de l'appareil. Déconnectez toujours l'appareil avant de modifier une partie du système fluïdique. Stoppez ou annulez toujours le processus avant de manipuler les appareils supplémentaires, comme le MACS MiniSampler Plus, ou de charger/ retirer les éprouvettes du râtelier à éprouvettes. L'utilisation sera fera avec l'aiguille dans son guide.

Dangers de radiation optique



Le MACSQuant® Instrument est désigné comme produit laser de la classe 1M selon la norme CEI 60825-1. Le MACSQuant Instrument est un instrument équipé de 3 lasers continue (classe laser 3B). Les lasers sont sécurisés par confinement grâce à un capot de protection. **Ne jamais retirer le capot de protection. L'utilisation d'élément de commandes autres que ceux mentionnés dans ce document ainsi que toute adaption ou utilisation d'autres procédés que ceux mentionnés dans ce document peuvent dégager des rayonnements dangereux.**



L'appareil est équipé pour la détection automatique de porte-échantillons (classe 1M) par quatre diodes laser à émission par la surface à cavité verticale (VCSEL). Le rayonnement est invisible.

Rayonnement invisible. Ne pas regarder avec des instruments optiques tels que des lunettes.

L'appareil est équipé d'un lecteur de code 2D ainsi que de diodes électroluminescentes (DEL) haute puissance pour l'éclairage du champ de lecture, des bouteilles de réactifs ainsi que de la poubelle. Diodes électroluminescentes (DEL) haute puissance sont également utilisées pour l'éclairage du champ de lecture, des bouteilles de réactifs ainsi que de la poubelle. Selon la norme internationale IEC 62471 de sécurité photobiologique, ce système de DEL a une valeur de risque d'exposition (EHV) de 0.91 et est au dessus du groupe de risque 0 (exempt risque).

Ne jamais retirer le capot de protection.

Ne démontez pas le support à bouteille à moins intégrer l'instrument dans un système de traitement des liquides. Si les porte-bouteilles sont enlevées, assurez-vous que les utilisateurs ne sont pas exposés à des rayonnements émis DEL.

Ne diriger le regard ni dans le rayon laser ou DEL direct, ni le rayon laser ou DEL réfléchi sur une surface de miroir. Sinon des lésions oculaires peuvent en résulter. Ne pas diriger intentionnellement le rayon laser sur d'autres personnes.

Prendre garde au chemin optique du rayon laser sur d'autres personnes. Veiller lors de l'installation de l'instrument à ce que le chemin optique rayon laser ne se trouve pas à hauteur des yeux de personnes pendant le service. Éviter que de l'eau, de l'huile, de la poussière ou d'autres corps étranger adhèrent sur la fenêtre de lecture du lecteur de code 2D. Ceci risque d'entraîner des erreurs de lecture. S'assurer avant le nettoyage du scanner qu'aucun rayon laser n'est plus émis. Sinon, l'exposition au laser peut provoquer des lésions oculaires. Utiliser un chiffon doux pour essuyer des substances sur le scanner. Ne pas utiliser d'alcool ou d'autres produits de nettoyage.

Ne pas démonter, échanger, ni retirer des sources de rayon laser ou DEL encastrées ni leur support. Les sources de rayon laser ou DEL ne cessent pas forcément d'émettre un rayonnement une fois démontées. Le rayonnement d'appareils démontés peut entraîner des lésions oculaires.

La distance de risque (HD) pour le groupe de risque 0 est de 61 cm. La distance de risque pour le groupe de risque 1 (risque faible) est de 20 cm.

EN

DE

ES

FR

IT

	Puissance de sortie	Durée d'impulsion	Longueur d'ondes
MACSQuant Analyzer 10			
Détection de porte-éprouvettes	3.3 mW	215 µs	850 nm
Laser interne 1	30 mW	Continu	488 nm
Laser interne 2	21.5 mW	Continu	404 nm
Laser interne 3	40 mW	Continu	640 nm
MACSQuant VYB			
Détection de porte-éprouvettes	3.3 mW	215 µs	850 nm
Laser interne 1	50 mW	Continu	488 nm
Laser interne 2	40 mW	Continu	404 nm
Laser interne 3	100 mW	Continu	561 nm
MACSQuant Analyzer 16			
Détection de porte-éprouvettes	3.3 mW	215 µs	850 nm
Laser interne 1	50 mW	Continu	488 nm
Laser interne 2	65 mW	Continu	404 nm
Laser interne 3	72 mW	Continu	642 nm

Table 5.1: Puissance de sortie de laser, durée d'impulsion, et longueur d'ondes.

Dangers chimiques et biologiques



Selon la matière biologique utilisée, une contamination et infection peut entraîner des blessures corporelles graves ou même la mort. Tout prélèvement clinique doit être considéré comme potentiellement contagieux.

Si des matières biologiquement dangereuses sont ou ont été utilisées, l'opérateur doit choisir et porter un équipement et des vêtements de protection, tel indiqué dans les avertissements et mesures de sécurité pour la substance respective. La mesure de sécurité mentionnée ci-dessus s'applique également pour toute substance chimique dangereuse, y compris toxique ou corrosive, acide ou radioactive, pouvant être présente dans le prélèvement.

Portez des gants et des vêtements de protection, ainsi que des lunettes protectrices, pour que la substance n'entre pas en contact avec la visage et les yeux. Un équipement de protection défectueux ou inadéquate est dangereux. Si des matières dangereuses ont été utilisées ou renversées, l'appareil doit soigneusement et complètement être décontaminé. Il est strictement interdit de continuer l'utilisation d'accessoires ou de pièces de l'appareil contaminées.

Protéger aussi la bouche et le nez des aérosols qui pourraient provenir du système. L'appareil doit être utilisé dans une hotte de sécurité, si des matières dangereuses ou inconnues sont traitées.

Tout liquide et déchet solide doivent être considérés comme dangereux et pour cela être traités selon les précautions universelles de laboratoire. L'enlèvement de déchets doit être conforme aux réglementations locales.

Des tubes et tout autre consommable qui étaient en contact avec des matières biologiquement dangereuses doivent être décontaminés avant d'être jetés. Les déchets liquides doivent être traités à l'autoclave ou décontaminés à l'aide d'un désinfectant adapté à l'agent pathogène spécifique, par ex. 10% eau de Javal, alcool isopropylique ou 70% d'éthanol.

Les pièces endommagées contenant du matériel biologique infectieux ou des liquides qui ont été en contact avec un tel matériel peuvent être potentiellement dangereuses.

Toujours vérifier le système fluïdique (le jeu complet de tubulures, les bouteilles et leurs bouchons, les valves, les colonnes, les diluants et les aiguilles) avant d'allumer l'instrument. Si des fuites sont détectées, remplacer les pièces endommagées avant d'allumer l'instrument. Si les pièces endommagées ne peuvent pas être remplacées, débrancher l'instrument et ne pas l'utiliser.

Maintenance et transport

Une maintenance ou réparation impropre ou incorrecte de l'appareil peut causer des dangers pour l'utilisateur, amener des résultats imprévisibles, causer un dysfonctionnement ou une détérioration de l'appareil, ainsi qu'une usure prématurée et une réduction de la longévité de l'appareil. Ceci peut également faire expirer votre garantie.

N'entretenez pas vous-même l'appareil, à moins que ceci ait été spécifiquement mentionné dans ce manuel ou d'autres documentations de Miltenyi Biotec. La maintenance et les réparations doivent être effectuées par un personnel de maintenance qualifié.

Si des pièces de rechange sont nécessaires, assurez-vous que le prestataire de services utilise uniquement des pièces authentiques de Miltenyi Biotec, ou des pièces de tiers spécifiées et recommandées par Miltenyi Biotec. L'utilisation de pièces non autorisées peut entraîner un dysfonctionnement de l'appareil et impacter les résultats. Miltenyi Biotec n'accorde aucune garantie ou ne prend aucune responsabilité pour des défauts de l'appareil ou des détériorations résultant de l'utilisation de pièces inappropriées. Après l'achèvement de tout travail de maintenance et de réparation, assurez-vous que votre prestataire de services Miltenyi Biotec agréé entreprenne tous les contrôles de sécurité, comme le demande la procédure de réparation pour garantir un fonctionnement normal de l'appareil.

Utilisez uniquement des options et extensions recommandées par Miltenyi Biotec. Renseignez-vous auprès de votre représentant local Miltenyi Biotec sur les arrangements extensives de support et de maintenance de l'appareil, ou bien référez vous à www.miltenyibiotec.com/support.

L'appareil doit être transporté avec soin dans des emballages spécifiés par Miltenyi Biotec. Une détérioration intérieure peut se produire, si l'appareil fait l'objet de vibrations excessives ou d'une chute. Si l'appareil doit être expédié de retour au fabricant pour la maintenance, décontaminez l'appareil pour éliminer toute matière dangereuse avant le chargement. Pour toute question concernant une décontamination ou un chargement correct, veuillez contacter le support technique de Miltenyi Biotec.

Élimination



Déchets d'Equipements Electriques et Electroniques (DEEE) - Information client

Pensez à recycler vos produits Miltenyi Biotec en fin de vie en conformité avec la directive DEEE en vigueur dans votre pays.

EN

DE

ES

FR

IT

Les équipements électroniques peuvent contenir des substances dangereuses, qui peuvent avoir un effet néfaste sur l'environnement et / ou la santé humaine. C'est pourquoi tous les équipements doivent être spécifiquement collectés et traités par les centres désignés et ce en conformité avec la Réglementation DEEE. En vous assurant que vous éliminez vos équipements électriques et électroniques en accord avec la législation en vigueur, vous contribuez à préserver nos ressources naturelles et à protéger la santé humaine.

La protection de l'environnement est au cœur de nos préoccupations. Ainsi, nous finançons de nombreux programmes de collecte et de recyclage des équipements électriques que nous mettons sur marché, en reversant une partie du prix de vente de nos produits à des éco-organismes agréés à travers le monde. Miltenyi Biotec vous permet de recycler gratuitement vos équipements Miltenyi Biotec en fin de vie. Les conditions et la disponibilité de cette offre varient selon les pays et les différentes exigences réglementaires. Selon le type et l'utilisation de votre équipement, des exigences supplémentaires peuvent s'appliquer.

Pour plus d'informations, ou si vous souhaitez recycler votre équipement Miltenyi Biotec en fin de vie, contactez votre interlocuteur Miltenyi Biotec ou notre support technique.



Importanti istruzioni di sicurezza

Avvisi e precauzioni



WARNING Il strumento è stato realizzato per garantire un uso sicuro, se installato correttamente, impiegato da personale specializzato e secondo la normativa generale di sicurezza e le istruzioni d'impiego contenute in questo manuale.

Le istruzioni in questa sezione spiegano i potenziali rischi associati all'uso di questo strumento e provvedono a fornire delle informazioni di sicurezza aggiuntive per minimizzare il rischio. Si seguano le istruzioni attentamente per proteggere voi stessi, gli altri e l'attrezzatura da potenziali pericoli e creare un ambiente di lavoro sicuro. Si utilizzi questo strumento solo come specificato dal produttore per evitare danni al prodotto o lesioni al personale. Si seguano sempre le indicazioni di sicurezza specifiche del luogo di lavoro e le disposizioni del laboratorio, nonché gli standard di salute, sicurezza e prevenzione incidenti. Si contatti l'autorità locale per il controllo delle forniture elettriche, le costruzioni della struttura, la manutenzione e la sicurezza, per ottenere maggiori informazioni in merito all'installazione sicura e l'impiego dello strumento.

Livelli di pericolo

Segnali di avviso sono in uso per identificare un uso sicuro e messaggi in caso di danni a cose personali. I seguenti segnali saranno in uso in questo manuale.













o **WARNING!** indica una situazione potenzialmente pericolosa, che, se non evitata, potrebbe causare morte o gravi danni.



o **CAUTION!** indica una situazione potenzialmente pericolosa, che, se non evitata, potrebbe causare danni minori e lesioni moderate. Può essere impiegato per segnalare procedure pericolose.

Simboli die sicurezza

Il seguenti simboli sono impiegati per sottolineare condizioni che potrebbero causare lesioni a persone o danni all'attrezzatura.

-  Avviso die sicurezza. Rischio die pericolo. Consultare il manuale di istruzioni ogni volta che questo simbolo di sicurezza viene utilizzato, per identificare la natura del potenziale pericolo e stabilire quali azioni intraprendere.
-  Rischio di scosse elettriche.
-  Forte campo magnetico.
-  Portatori di pacemaker o dispositivi medici elettronici devono mantenere una adeguata distanza di sicurezza.
-  Rischio di schiacciamento o di taglio di parti del corpo.
-  Radiazione ottica pericolosa.
-  Radiazione laser pericolosa.
-  Rischio biologico. Rischio di contaminazione se è in uso materiale biologico potenzialmente pericoloso.
-  Morsetto di protezione. Questo simbolo è applicato internamente allo strumento. Si tratta di informazioni per il personale di servizio.
-  On (Alimentazione).
-  Off (Alimentazione).

EN

DE

ES

FR

IT

Etichetta di sicurezza

Prendere visione dei punti critici e dei simboli di sicurezza del strumento. Le etichette di sicurezza e i marchi di sicurezza devono essere mantenuti puliti e leggibili. Ispezionare periodicamente le etichette di sicurezza e i marchi di sicurezza e sostituirli se illeggibili o percettibili da una distanza di sicurezza. Contattare Miltenyi Biotec per delle etichette sostitutive.

Etichetta di sicurezza

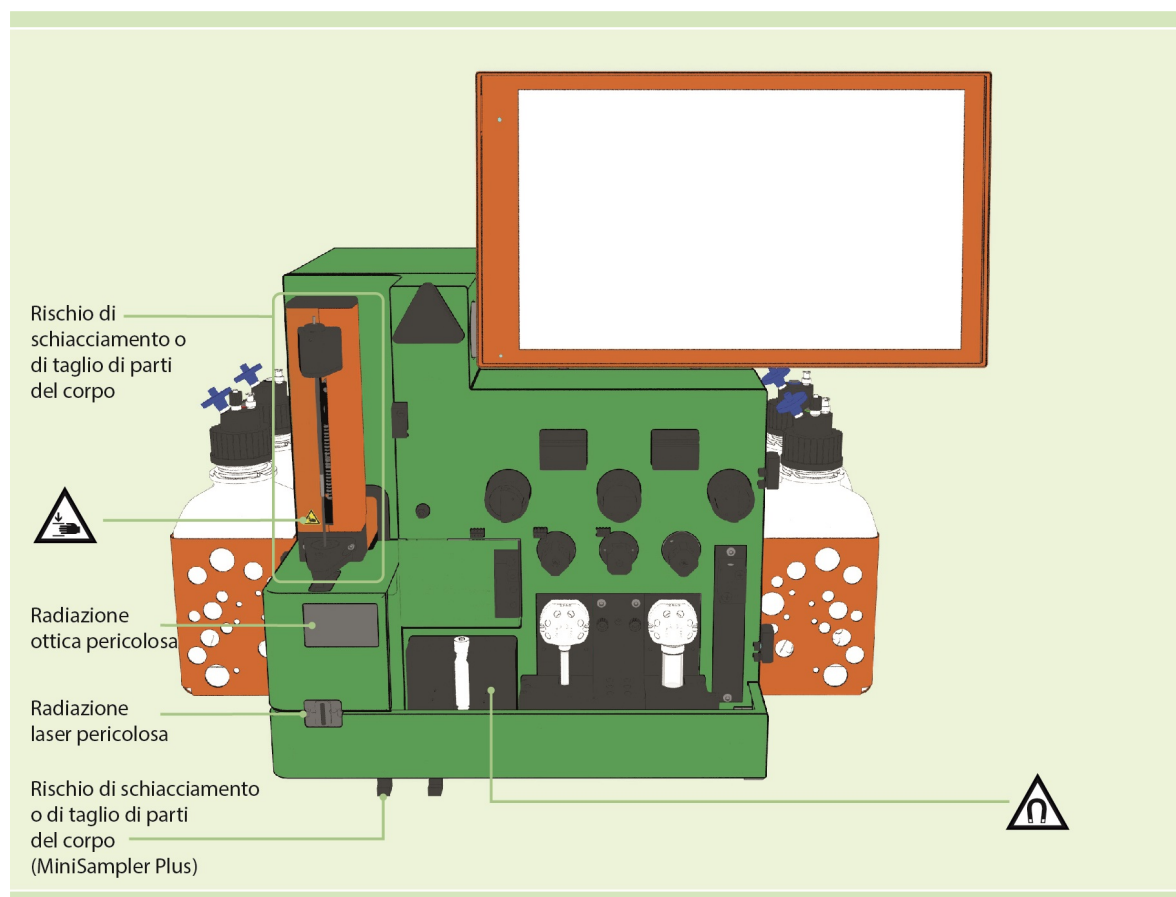

Figure 1: Punti critici e posizioni dei simboli di sicurezza sulla parte frontale del MACSQuant® Instrument.

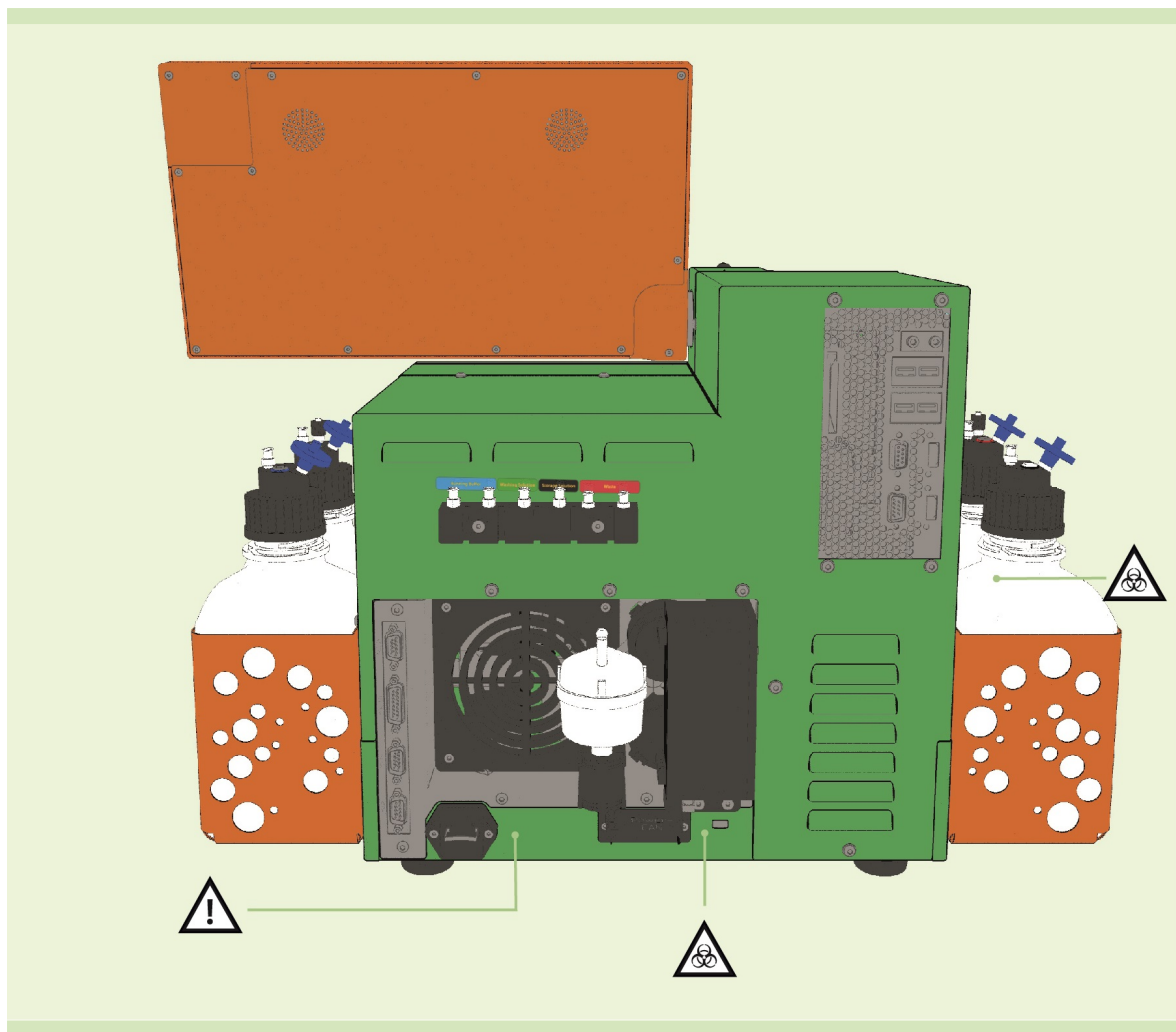

Figure 2: Posizione dei simboli di sicurezza sulla parte posteriore del MACSQuant® Instrument.

Istruzioni generali di sicurezza



Se lo strumento non funziona correttamente e/o le istruzioni visualizzate dei messaggi di avviso suggeriscono di contrattare l'assistenza tecnica, non è più possibile un uso sicuro dello strumento. Si spenga immediatamente lo strumento e lo si scollegi dalla presa di corrente, quindi si contatti il service provider Miltenyi Biotec o Miltenyi Biotec Technical Support.

Rischi elettrici e pericolo d'incendio



Possibili rischi derivati da dispositivi elettrici includono scosse elettriche, corti e surriscaldamenti. Una scossa elettrica potrebbe causare gravi lesioni personali o perfino la morte.

Un corto elettrico o un surriscaldamento potrebbero causare un incendio. Le apparecchiature elettriche possono generare scintille, che potrebbero incendiare vapori combustibili o materiali, causando esplosioni o incendi.

No si utilizzi lo strumento in aree classificate come postazioni pericolose, p. e. in ambienti carichi di ossigeno. Se si vedono fiamme o fumo, si escluda immediatamente l'alimentazione, si scollegi lo strumento dalla presa di corrente e si contatti un service provider Miltenyi Biotec o Miltenyi Biotec Technical Support.

Il corpo dello strumento è stato realizzato per ridurre il rischio di scosse elettriche, corti elettrici e la dispersione di fuoco. **Tranne per l'accesso frontale copre, non si rimuova o si apra alcun rivestimento. Solo il personale autorizzato può rimuovere le altre protezioni dello strumento. Non si inserisca mai alcun oggetto esterno nelle aperture dello strumento.**

No si usi lo strumento se

- è aperto o smontato
- è caduto o danneggiato
- ha danni o ha parti rotte
- ha il cavo di alimentazione danneggiato
- un oggetto è entrato nelle fessure di ventilazione
- un oggetto esterno è stato inserito nello strumento

Lo strumento è stato realizzato per un uso esclusivamente al coperto. Se dei fluidi entrano nello strumento, potrebbero verificarsi dei corti elettrici, scosse elettriche o fuoco. Si faccia particolare attenzione quando si ha a che fare con sostanze liquide.

Si faccia in modo che le stesse non fluiscano internamente all'apparecchio. Si protegga l'apparecchio da fuoriuscite improvvise o getti d'acqua. Si puliscano immediatamente le fuoriuscite. Non si faccia uso dello strumento se delle sostanze liquide sono venute a contatto con lo stesso. No si usi l'apparecchio in un ambiente umido o con vapore. Si evitino aree con elevata umidità o rischio di condensazione. Spostare lo strumento da un ambiente freddo (come p.e. una stanza fredda a 5°C) potrebbe causare condensazioni interne allo stesso. In tal caso si aspetti che lo stesso si deumidifichi, prima di renderlo nuovamente operativo.

Si stacchi lo strumento dalla presa elettrica prima di pulirlo. No si usino liquidi o prodotti di pulizia aerosol; si usi sempre un panno umido.

Proteggere lo strumento dal surriscaldamento. Non utilizzare lo strumento in aree con più di 25° C. Assicurare una adeguata circolazione d'aria nella stanza quando si aziona lo strumento. Permettere la circolazione dell'aria sufficiente intorno allo strumento – di almeno 15 cm su tutti i lati – durante il funzionamento. **Non posizionare lo strumento vicino radiatori, termoregolatori, stufe o altri apparecchi (inclusi gli amplificatori) che generano calore. Proteggere lo strumento dalla luce solare diretta. Non si coprano gli slots le aperture dello strumento , poiché le stesse sono previste per la ventilazione e per proteggere lo strumento da surriscaldamento.** Non si posizioni lo strumento in uno scomparto integrato o in un analogo spazio limitato, a meno che esso non si stato appositamente realizzato i modo tale da garantire un'adeguata ventilazione. Si seguano le istruzioni di montaggio dello strumento.

Lo strumento è fornito di una spina con tre conduttori ed un terzo pin per il collegamento a terra. Questa spina può essere collegata solamente con una presa di corrente a terra. Si tratta di una misura di sicurezza. **Non si provi ad inserire la spina in una presa non a terra.** Nel caso non si riesca ad inserire la spina nella presa, si contatti l'elettricista di fiducia per sostituirla.

Soltanto le periferiche conformi a UL 60950 possono essere collegate al connettore RS232 contrassegnato con COM1. È inoltre possibile collegare soltanto apparecchi MACSQuant Instrument originali ai connettori contrassegnati con External CAN.

Solamente il lettore 2D che sia stato consegnato con lo strumento deve essere collegato al connettore R232/BCR. I dispositivi laser laser esterni collegati al connettore contrassegnato come RS232/BCR devono essere conformi alla norma IEC 60825-1.

Per assicurare la compatibilità elettromagnetica, connettere le parti periferiche solo con cavi a doppia schermatura ed utilizzare esclusivamente il cavo di alimentazione e tastiera di lunghezza. Utilizzare unicamente cavi di connessione inferiori ai 3 metri di lunghezza. La tastiera deve essere utilizzata solo con i modelli MACSQuant® Instrument.

Ci si assicuri che gli interruttori di rete principali, così come il cavo di connessione alla corrente siano facilmente accessibili e ubicati il più vicino possibile all'operatore. Se è necessario sconnettere l'alimentazione, si contatti l'elettricista di fiducia per sostituirla.

Lo strumento dovrebbe venire alimentato solamente da una fonte di alimentazione che rispetti le specificazione menzionate nell' etichetta di indicazione elettrica del prodotto. Nel caso si fossero domande in merito al tipo di fonte energetica, si contatti il service provider Miltenyi Biotec autorizzato o la compagnia energetica di fornitura locale.

Non si usino prolunghe o prese multiple. Non si sovraccariche una presa elettrica.



Forte campo magnetico

Il strumento è dotato di un magnete estremamente potente. Esiste un forte rischio per la salute di portatori di pacemaker, drenaggi cerebrali o impianti medicali.



Tenere i dispositivi di storage magnetici, apparecchiature elettroniche e oggetti. Tenere tutti i dispositivi di storage magnetici, apparecchiature elettroniche e oggetti magnetizzabili ad una distanza minima di 20 cm.



Rischi meccanici

Spostare o far ruotare le parti potrebbe causare rischi di natura meccanica.

Non aprire i coperchi di accesso anteriore mentre il dispositivo è in funzionamento. Non impedire il movimento del braccio automatizzato e degli accessori hardware durante il funzionamento. Esiste il rischio di pungersi, schiacciamento e di taglio parti del corpo. Tenere le dita, ecc. , lontano da tutte le parti in movimento del strumento e degli accessori hardware. Non bypassare alcun dispositivo o misura di sicurezza.

Non toccare le pompe dei liquidi e non sposare i tubi mentre il dispositivo è in funzione. Spegner sempre il dispositivo prima di regolare eventuali parti del sistema della fluidica. Interrompere o sospendere sempre una procedura prima di maneggiare gli accessori hardware, ad es. il campionatore MACS MiniSampler Plus, o prima di caricare/rimuovere le provette dal portaprovette. Utilizzare solamente con la relativa protezione dell'ago.

Rischi di radiazioni ottiche



Il MACSQuant® Instrument è classificato come prodotto laser della classe 1M secondo lo standard IEC 60825-1. Il MACSQuant Instrument è equipaggiato con tre laser (laser di classe 3B). Questi laser sono mantenuti in appositi alloggiamenti. **Non rimuovere le protezioni degli alloggiamenti. L'utilizzo di comandi o regolazioni o l'esecuzione di procedure diverse da quanto qui specificato può essere causa di esposizione a radiazioni pericolose.**



L'apparecchio è dotato di quattro laser a emissione superficiale a cavità verticale (VCSEL) per il rilevamento automatizzato (classe 1M). La radiazione non è visibile.

Raggio laser invisibile. Non osservare con strumenti ottici.

L'apparecchio è dotato di un lettore di codici 2D e di potenti diodi luminosi (LED) per illuminare la zona di lettura. I LED potenti sono anche utilizzati per illuminare le bottiglie fluido e la bottiglia rifiuti. Rispetto allo standard IEC 62471, la lampada ha un valore di rischio relativo all'esposizione (EHV) pari a 0.91 ed è in eccesso rispetto al Gruppo Esente da Rischio.

Non rimuovere le protezioni degli alloggiamenti.

Non rimuovere i cestelli per il bottiglie. If the bottle holders are removed, make sure users are not exposed to emitted LED radiation.

Non guardare direttamente le radiazioni di diodi laser o LED o le radiazioni di diodi laser o LED riflesse da una superficie a specchio. In caso contrario si potrebbero danneggiare i propri occhi. Non rivolgere il raggio laser verso altre persone.

Fare attenzione al percorso del raggio laser o a riflessi da una superficie a specchio. Durante l'installazione del strumento, accertarsi che il percorso del raggio laser non si trovi alla stessa altezza degli occhi di chi esegue il lavoro. Evitare che acqua, grasso, polvere o altre sostanze estranee si depositino sulla finestra di lettura. Ciò potrebbe comportare errori di lettura. Accertarsi di aver arrestato l'emissione laser prima di pulire il lettore. Un'esposizione al raggio laser potrebbe danneggiare i propri occhi. Utilizzare un panno morbido e asciutto per rimuovere qualsiasi sostanza dal lettore di codici a barre. Non utilizzare alcol o altre sostanze detergenti.

Le radiazioni di unità smontate possono essere causa di lesioni agli occhi. **Non smontare, modificare o rimuovere le sorgenti di radiazioni laser o LED installate o le loro staffe di montaggio. Le sorgenti di radiazioni laser o LED non cessano automaticamente di emettere radiazioni una volta smontate.**

La distanza a rischio (HD) per il Gruppo Esente da Rischio è 61 cm. La distanza a rischio per il Gruppo a Rischio 1 è die 20 cm.

	Potenza di uscita	Durata dell'impulso	Lunghezza d'onda
MACSQuant Analyzer 10			
Rilevamento del portaprovette	3.3 mW	215 µs	850 nm
Laser interno 1	30 mW	Continuativo	488 nm
Laser interno 2	21.5 mW	Continuativo	404 nm
Laser interno 3	40 mW	Continuativo	640 nm
MACSQuant VYB			
Rilevamento del portaprovette	3.3 mW	215 µs	850 nm
Laser interno 1	50 mW	Continuativo	488 nm
Laser interno 2	40 mW	Continuativo	404 nm
Laser interno 3	100 mW	Continuativo	561 nm
MACSQuant Analyzer 16			
Rilevamento del portaprovette	3.3 mW	215 µs	850 nm
Laser interno 1	50 mW	Continuativo	488 nm
Laser interno 2	65 mW	Continuativo	404 nm
Laser interno 3	72 mW	Continuativo	642 nm

Table 6.1: Potenza di uscita, durata dell'impulso, e lunghezza d'onda.

Rischi chimici e biologici



In base al materiale biologico impiegato, alla contaminazione o all'infezione, possono verificarsi gravi lesioni a persone o anche morte. Tutti i casi clinici devono essere considerati come potenzialmente infetti.

Se un materiale a rischio biologico è o è stato in uso, l'operatore deve scegliere ed indossare delle protezioni di sicurezza personali come indicato negli avvisi e le precauzioni specifiche per la particolare sostanza. Le precauzioni di sicurezza sopra indicate considerano qualsiasi altra sostanza chimica rischiosa, incluse sostanze tossiche e corrosive, acide o radioattive che potrebbero essere presenti nel campione.

Si indossino guanti e abiti di sicurezza, nonché occhiali protettivi per prevenire il contatto tra la sostanza ed il corpo e gli occhi. L'uso di abbigliamento protettivo danneggiato o inadeguato può essere pericoloso. Nel caso in cui del materiale pericoloso sia stato utilizzato o sia fuoriuscito, si faccia molta attenzione quando si sterilizzi (decontamini) lo strumento. E' severamente proibito continuare ad utilizzare parti contaminate o altri accessori dello strumento.

Anche proteggere la bocca e il naso dagli aerosol che possono provenire dal sistema. Lo strumento deve essere impiegato all'interno di un'area protetta nel caso vengano impiegato materiali pericolosi o sconosciuti.

Tutti rifiuti liquidi e solidi dovranno essere considerati pericolosi e quindi essere trattati secondo le precauzioni universali da laboratorio. Lo smaltimento dei rifiuti dovrà avvenire in accordo con le normative locali vigenti.

Le provette o il materiale ausiliario entrati in contatto con materiali biologici pericolosi dovranno essere sterilizzati prima dello smaltimento. I rifiuti liquidi vanno autoclavati o decontaminati utilizzando un disinfettante idoneo per il patogeno specifico, ed es. candeggina al 10%, alcol isopropilica o etanolo al 70%.

Il malfunzionamento di parti che contengono materiale potenzialmente infettivo o liquidi venuti in contatto con tali materiali possono rappresentare un pericolo.

Ispezionare sempre il sistema fluidico (il sistema di tubi, le bottiglie e le relative chiusure, le valvole, le colonne, il dispositivo di diluizione e gli aghi) prima di accendere lo strumento. In caso di perdita di liquidi, sostituire le parti danneggiate prima di accendere lo strumento. Nel caso non sia possibile sostituire le parti danneggiate, disconnettere lo strumento e non utilizzarlo.

Manutenzione e trasporto

Una manutenzione impropria o scorretta ovvero riparazioni dello strumento possono causare pericolo per gli utenti o portare a danni irreparabili, causare un malfunzionamento dello strumento o danni, nonché usura prematura e ridotta vita utile dello stesso. Potrebbe inoltre fare cadere la Vostra garanzia.

A meno che non diversamente specificato in questo manuale o in altra documentazione Miltenyi Biotec, non si faccia la manutenzione dello strumento da soli. La manutenzione e le riparazioni devono essere condotte da personale di servizio qualificato.

Sostituendo componenti o se sono necessari pezzi di ricambio, assicurarsi che il service provider usi solo parti originali Miltenyi Biotec o altrimenti terze parti consigliate e raccomandate da Miltenyi Biotec. L'utilizzo di parti non originali può causare malfunzionamenti dello strumento e risultati imprecisi. Miltenyi Biotec non offre alcuna garanzia né accetta alcuna responsabilità per danni alla strumentazione o guasti dovuti ad un uso sconsigliato dei componenti. Dopo aver completato ogni servizio di manutenzione e lavoro di riparazione, ci si assicuri che il service provider Miltenyi Biotec autorizzato esegua tutti i controlli di sicurezza previsti dalle procedure, per garantire che lo strumento funzioni in modo corretto.

Si usino solo opzioni ed aggiornamenti raccomandati da Miltenyi Biotec. Si chiedano informazioni al rappresentante locale di Miltenyi Biotec in merito al servizio esteso di strumenti Miltenyi Biotec's e le modalità di supporto, o ci si riferisca a www.miltenyibiotec.com/support.

Lo strumento dovrebbe essere trasportato con cura nell'imballo specificato da Miltenyi Biotec. Danni interni possono essere provocati da eccessive vibrazioni o se lo strumento dovesse cadere. Nel caso l'apparecchio debba essere spedito al produttore, lo si sterilizzi per eliminare ogni sostanza pericolosa prima della spedizione. Nel caso ci fossero domande in merito all'adeguata pulizia o la spedizione, si contatti per l'assistenza il Miltenyi Biotec Technical Support.

Smaltimento



Informazioni per i clienti riguardi lo smaltimento delle apparecchiature elettriche ed elettroniche secondo le normative WEEE (Waste of Electrical and Electronic Equipment)

Si prega di smaltire i prodotti Miltenyi Biotec in disuso secondo le disposizioni di legge riguardanti lo smaltimento di apparecchiature elettriche ed elettroniche (WEEE) e dei rifiuti pericolosi, che possono differire da paese a paese.

Le apparecchiature elettriche ed elettroniche possono contenere sostanze pericolose, che possono avere un grave effetto dannoso per l'ambiente e / o la salute umana. È per questo che tutte le attrezzature devono essere specificamente raccolte e trattati da centri di smaltimento abilitati e qualificati in conformità con la normativa WEEE. Il corretto smaltimento delle apparecchiature elettriche ed elettroniche secondo le disposizioni di legge WEEE e dei rifiuti pericolosi, possono aiutare preservare le risorse naturali e a tutelare la salute umana.

Miltenyi Biotec si impegna a proteggere l'ambiente. Miltenyi Biotec offre programmi per lo smaltimento dei prodotti dismessi in molti paesi e partner accreditati per lo smaltimento secondo le normative WEEE in tutto il mondo. Miltenyi Biotec consente di riciclare le apparecchiature Miltenyi Biotec gratuitamente. Le condizioni e la disponibilità di questa offerta variano da zona a zona a causa di differenze legislative. Si prega, di notare che, a seconda del tipo e dell' utilizzo delle apparecchiature, possono essere necessari requisiti aggiuntivi.

Per ulteriori informazioni, o se si desiderassero smaltire le apparecchiature Miltenyi Biotec in disuso, si prega di contattare il Responsabile di Zona o il Supporto Tecnico Miltenyi Biotec.

EN

DE

ES

FR

IT

This user manual applies to

- MACSQuant® Analyzer 10 (# 130-096-343)
- MACSQuant® VYB (# 130-096-116)
- MACSQuant® Analyzer 16 (# 130-009-803)

In the following, the name MACSQuant Instrument refers to all three instruments. Unless further specified, the stated information applies to all instrument models.

MACSQuant Instruments are compact flow cytometers that combine multisample and multiparameter sample analysis with unrivaled ease of use. With processing rates of up to 15,000 events per second, they facilitate also absolute quantification of cell populations. MACS® Antibodies and Cell Separation Reagents are designed for easy and convenient handling with MACSQuant Instruments. Miltenyi Biotec is leading provider of comprehensive solutions for flow cytometry.

1.1 Intended use

The MACSQuant Instrument is a digital bench top flow cytometer equipped with three lasers for cellular analysis. Units are equipped with an enrichment unit for the pre-analysis enrichment of rare cells. It is intended for both phenotypic analysis with fluorescent antibodies and functional analysis of fluorescently labelled cells. The MACSQuant Instrument is intended for research use only. Only laboratory personnel are allowed to use the MACSQuant Instrument. The instrument is intended to be used only as stated in the provided instructions.

1.2 Key features of the MACSQuant® Instrument

- An integrated computer controlled by a touchscreen runs the MACSQuantify™ Software, which is used for sample acquisition as well as for data analysis.
- A fully automated computer-controlled robotic needle arm delivers samples to the sample injection port, which is located in the washing station. The uptake needle as well as the sample injection port are automatically washed during and after cell processing for your convenience.
- The Single tube rack is used for the analysis of individual samples.
- The optional MACS® MiniSampler Plus allows fully automated multiple sample processing. It holds different tube racks that are automatically recognized by a 2D code reader, as well as the Universal Reagent Rack.
- A color-coded and easy to access fluidics system supplies the MACSQuant Instrument with all buffers and solutions required during and after operation. The sheath particle filter prevents any debris from entering the fluidics system.
- Bottles for Running Buffer, Washing Solution, and Storage Solution are placed in bottle holders. Liquid waste is collected in a separate waste bottle. All fluid levels are constantly monitored and visualized by the illumination of the fluid bottles.

- The MACS Enrichment Unit with the optional MACSQuant Column allows easy analysis of particularly challenging cell samples, such as rare cell populations in high volumes of buffer, or precious low volume samples.

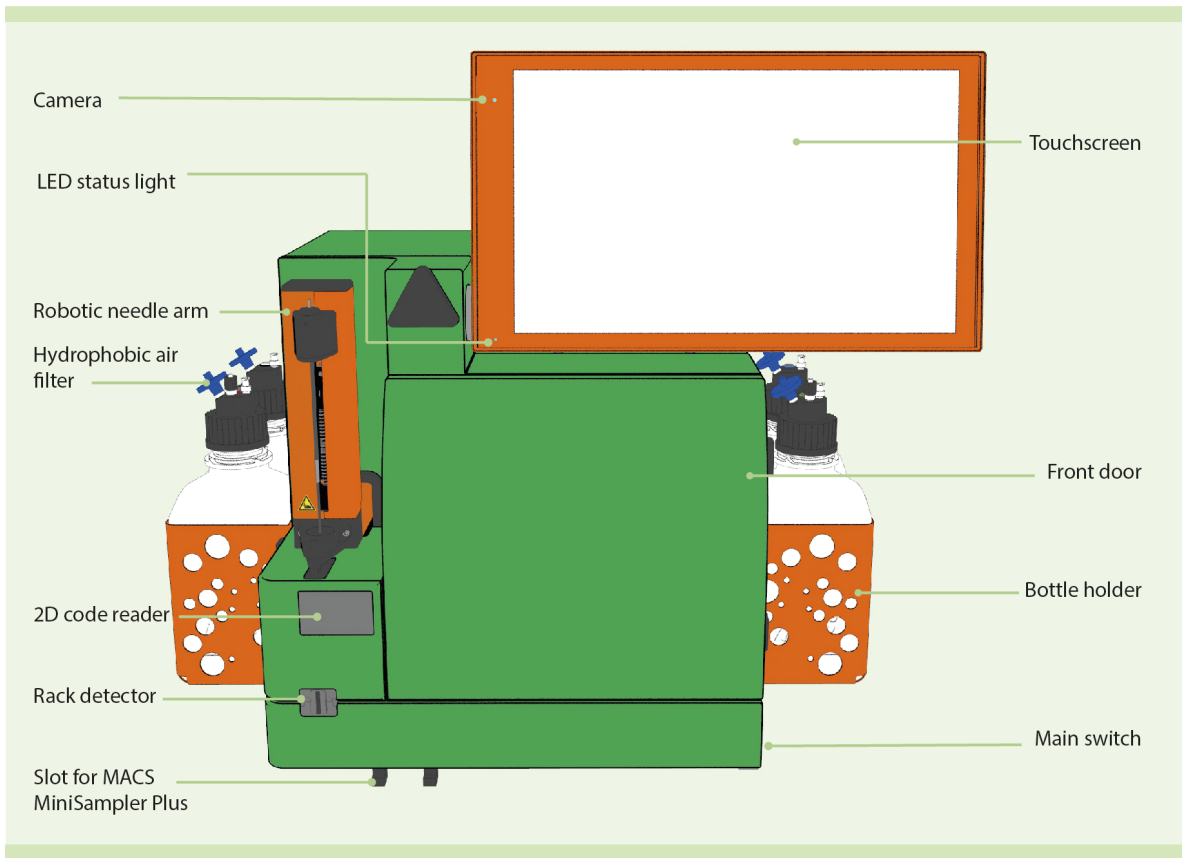

Figure 1.1: Front view of the MACSQuant® Instrument.

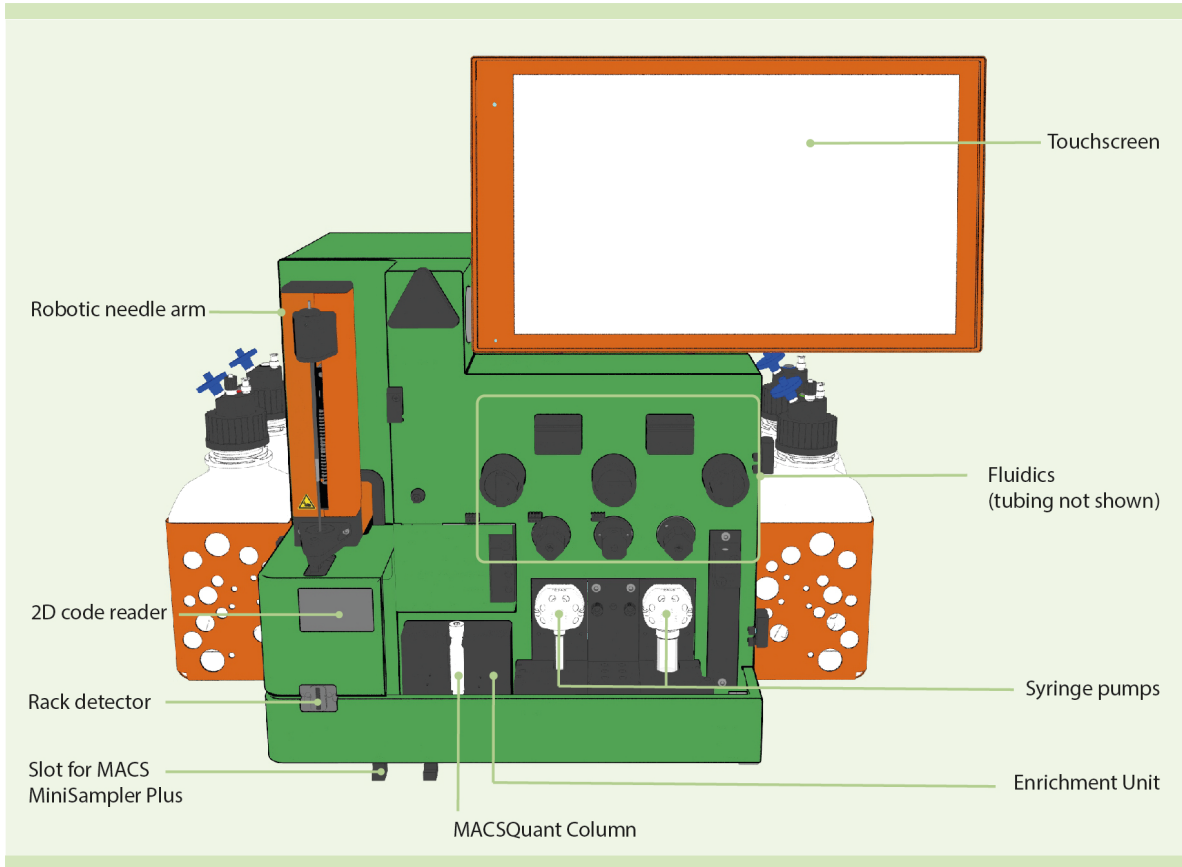

Figure 1.2: Front view of the MACSQuant® Instrument, door not shown.

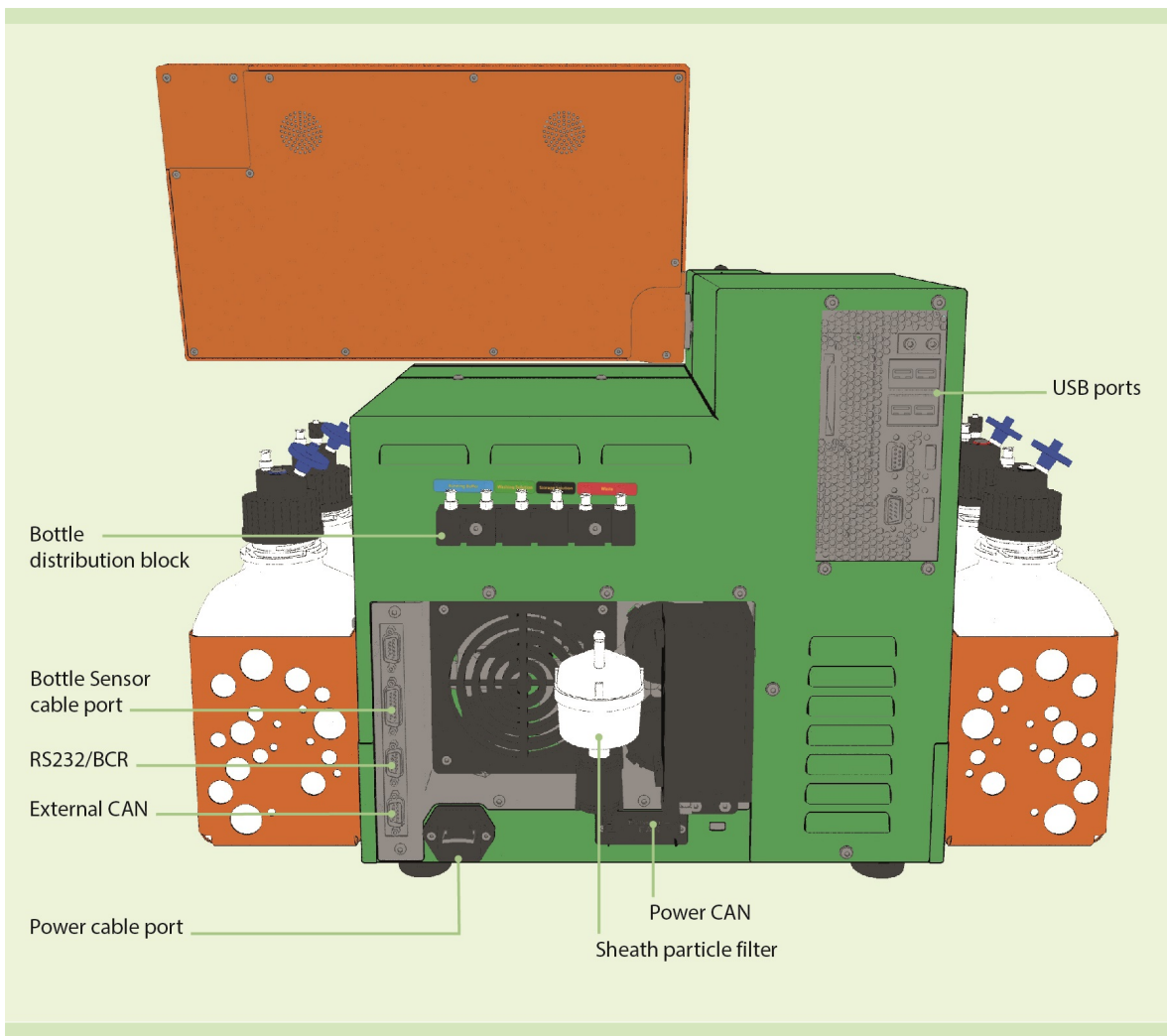

Figure 1.3: Rear view of the MACSQuant® Instrument.

2

Installation

WARNING If there is any damage, do not use the instrument but contact your local Miltenyi Biotec representative or Miltenyi Biotec Technical Support. The operation of a damaged instrument may lead to the exposure of mechanical hazards, optical radiation hazards, electric shock, or the spread of fire. Read the chapter **Important safety information** before continuing with installation and assembly. Read through the following instructions carefully before commencing the installation procedure.

Before opening the transportation box, check for any visible external damage to the box. Check also to see if the shock and position indicators (if present) suggest incorrect transportation of the instrument.

The instrument is designed to fit onto benchtops, into standard size laminar flows, into safety cabinets, or in connection to fully automated liquid handling systems. It should be installed on a stable, flat and vibration-free surface. The operating environment should be dust-free, sufficiently ventilated, and free from sources of electromagnetic radiation. In order to ensure a flat surface in laminar flow hoods, the instrument can be placed on a MACS® Laminar Hood Plate.

2.1 Components included in the delivery

Component
MACSQuant Instrument
Fluid sensor cable module
Power cable
6 × Fluidics tubing
4 × Bottle closure with sensors
Single tube rack
User manual
Empty bottles with screw caps
Keyboard
Webcam
Hydrophobic Air Filters
MACSQuant Calibration Beads
MACSQuant Starting Buffer Kit

2.2 Consumables

Component	Description	Order no.
MACSQuant Columns	For use with the MACS Enrichment Unit	130-094-458
Hydrophobic Air Filter	To vent fluid bottles	130-090-385
MACSQuant Calibration Beads	For instrument calibration	130-093-607
MACSQuant Running Buffer	6 × 1.5 L	130-092-747
MACSQuant Running Buffer (16x)	1 × 1.25 L	130-111-562
MACSQuant Running Buffer (16x)	6 × 1.25 L	130-111-747
MACSQuant Washing Solution	6 × 1.5 L	130-092-749
MACSQuant/MACSimas Storage Solution	6 × 1.5 L	130-092-748
MACSQuant Starting Buffer Kit	4 × 1.5 L Running Buffer 1 × 1.5 L Washing Solution 1 × 1.5 L MACSQuant/MACSimas Storage Solution	130-094-190
MACSQuant Washing & Storage Solution Kit	3 × 1.5 L Washing Solution 3 × 1.5 L MACSQuant/MACSimas Storage Solution	130-092-801
MACS Comp Bead Kit, anti-human Igk	for 100 tests	130-104-187
MACS Comp Bead Kit, anti-mouse Igk	for 100 tests	130-097-900
MACS Comp Bead Kit, anti-rat Igk	for 100 tests	130-107-755
MACS Comp Bead Kit, anti-REA	for 100 tests	130-104-693

2.3 Accessories

Complementary components can be ordered separately.

Component	Description	Order no.
MACS MiniSampler Plus	Use with the Universal Reagent Rack and one of the three Chill Racks for automated multisample processing.	130-105-745
Chill 5, 15, 50 Rack Set	Set of cooling racks	130-097-038
Chill 5 Rack	Cooling rack for 24 × 5 mL tubes	130-092-951
Chill 15 Rack	Cooling rack for 15 × 15 mL tubes	130-092-952
Chill 50 Rack	Cooling rack for 6 × 50 mL tubes	130-092-953
Chill 96 Rack	Cooling rack for 96-well plates	130-094-459
Buffer Supply Station	To connect larger fluid containers	130-101-841
Sample Racks	Universal Reagent Rack	130-115-722

2.4 Service contracts

For information about available service contracts for the MACSQuant Instrument, please visit www.miltenyibiotec.com/.

2.5 Assembly

2.5.1 Install the fluid bottles

Operating the instrument requires Running Buffer, Washing Solution, and Storage Solution. One bottle is required for waste collection. Always operate the instrument with ready-to-use MACS® Buffers and solutions only. The bottles, closures, tubing and fluid sensor cables are color-coded for easier handling.

- 1 Install only one fluid bottle at a time. Place the new bottle into the orange bottle holder. Please note the corresponding color coding.
- 2 Unscrew the lid of the fluid bottle and replace it with the appropriate bottle closure delivered with the instrument.
- 3 Remove the caps from the bottle distribution block and connect the tubing to the appropriate color-coded fluid port of the bottle distribution block on the back of the instrument (refer to **Figure 1.3**).

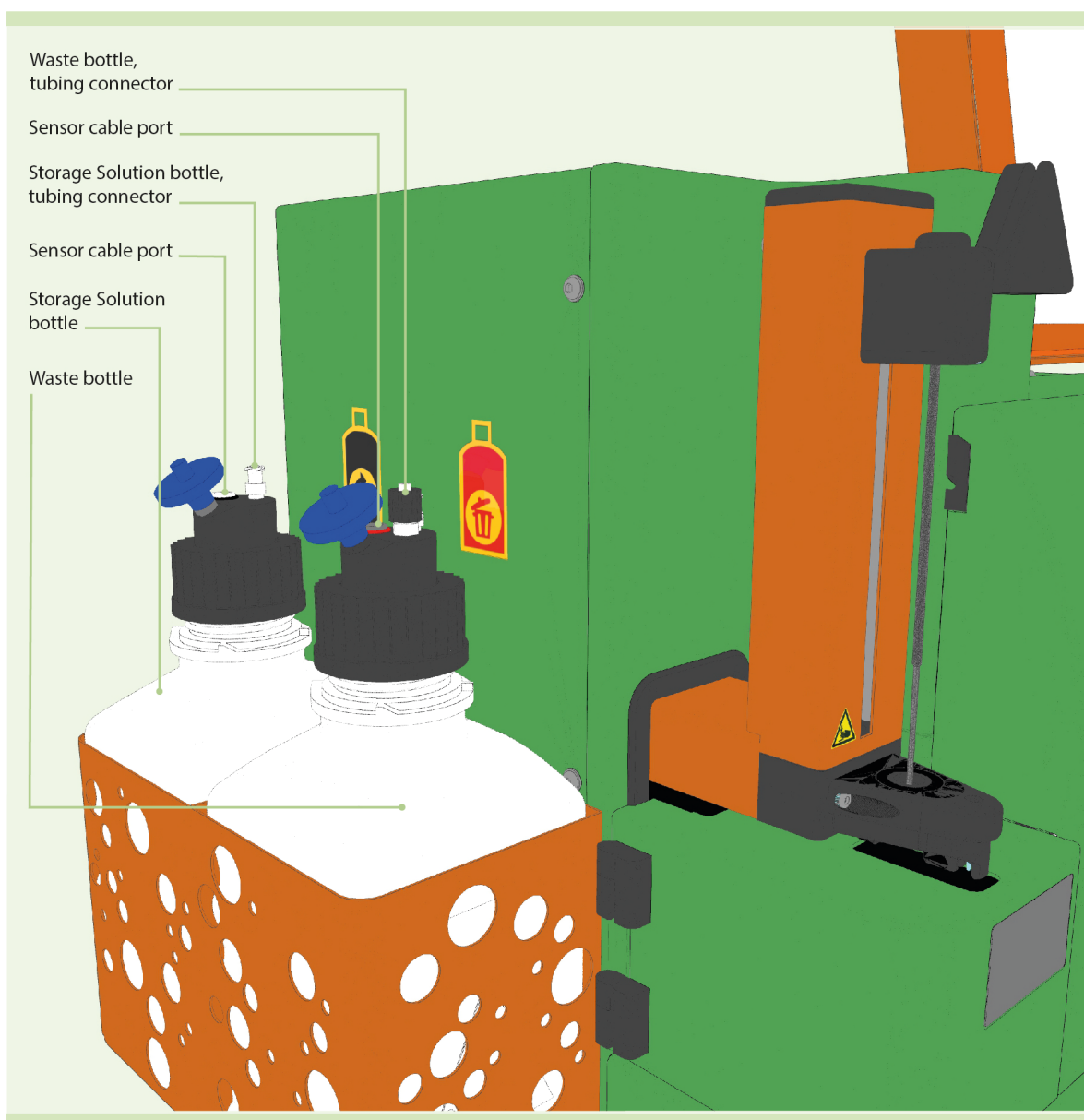

Figure 2.1: Connect Waste and Storage Solution bottle.

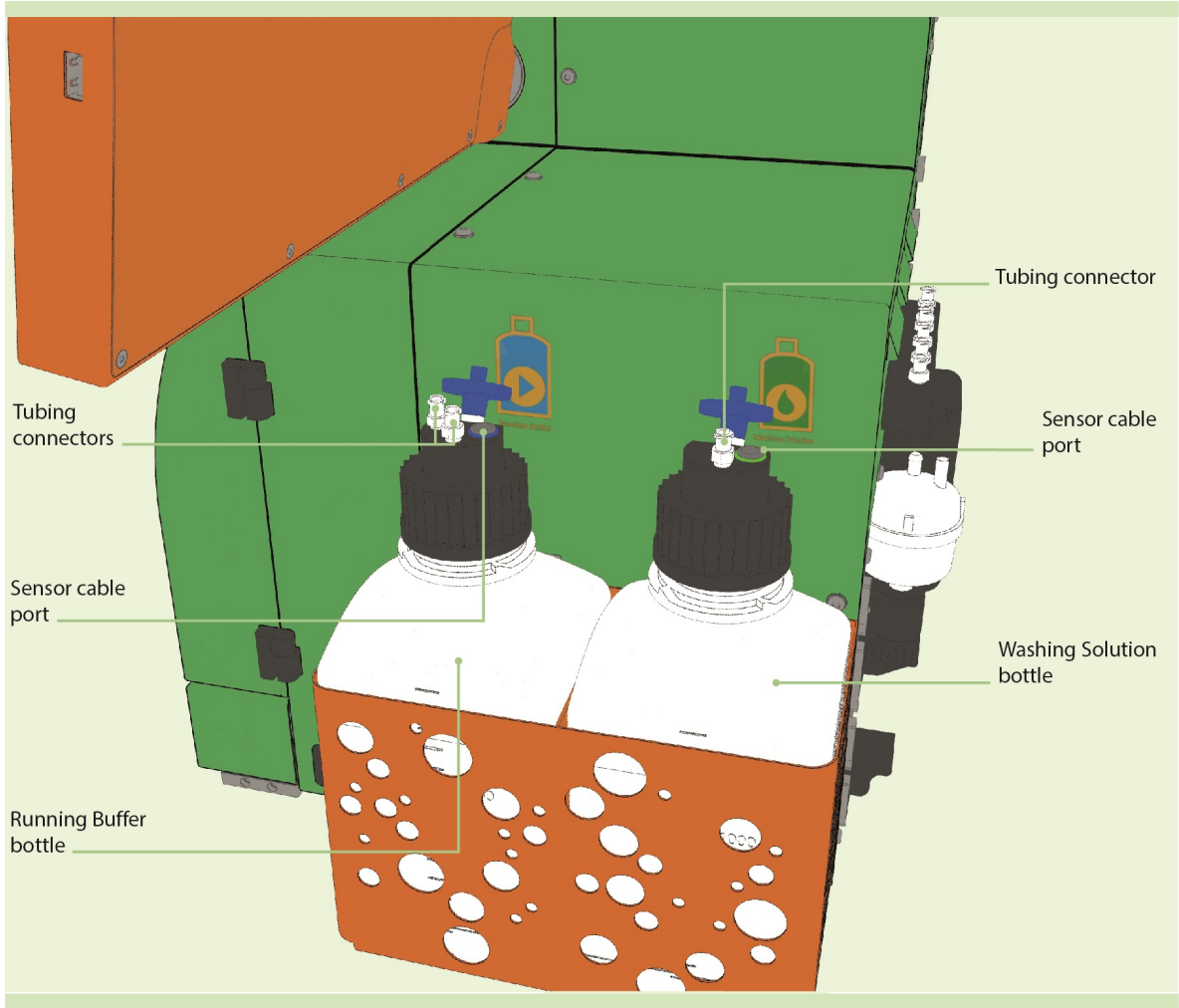

Figure 2.2: Connect Running Buffer and Washing Solution bottle.

- 4 Note the color coding of the tubes and connect them to the respective bottle closure.
- 5 Connect the 4-end fluid sensor cable to the port labeled **Bottle Sensor** at the back of the instrument (see **Figure 1.2**) and fasten securely.
- 6 Note the color coding and connect each fluid sensor cable to the respective bottle closure.
- 7 Connect a hydrophobic air filter to the appropriate connectors on the bottle closures to keep buffers sterile. Avoid any contact with liquids, as this may cause clogging of the filter.
- 8 Connect a hydrophobic air filter to the appropriate connector behind the sheath particle filter at the back of the instrument. If necessary, loosen the white lid on top of the sheath particle filter to purge the system.

	Running Buffer	Washing Solution	Storage Solution	Waste container
Icon				
Color of sensor cables and tubes	blue	green	black	red

Table 2.1: Bottle symbols and their respective color-coding.

2.5.2 Install the Single tube rack

The instrument is delivered with the Single tube rack. The Single tube rack is compatible with all standard flow cytometry tubes (1.5 mL, 2 mL, and 5 mL).

- 1 Gently insert the Single tube rack into the corresponding slots located at the front of the instrument. The rack should click into place.
- 2 To remove the Single tube rack, hold it between two fingers and pull gently.

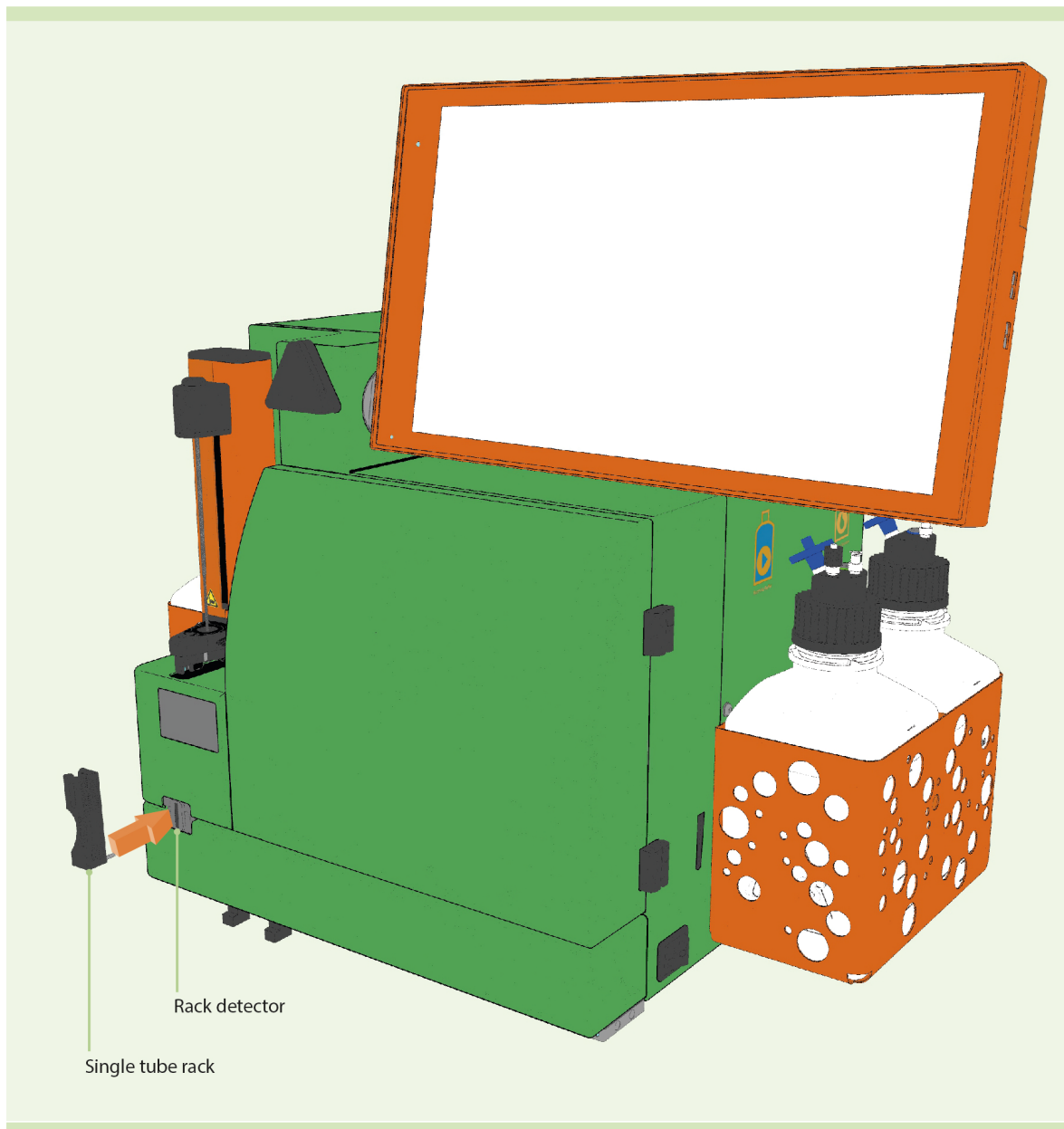

Figure 2.3: Installation of the Single tube rack.

2.5.3 Connect the instrument to the power supply

- 1 Connect the power cord to the power socket at the rear side of the instrument. The main power switch is located on the right side of the instrument (**Figure 1.1**). Ensure that the main switch is in position O (off) before connecting the power cord.
- 2 Attach the cable coming from the 2D code reader to the port labeled **RS232/BCR** at the back of the instrument and fasten securely.
- 3 Plug in the power cord to a grounded power outlet.

- 4 Switch on the instrument to turn it into stand-by mode. The MACSQuantify Software will automatically power up if you touch the touchscreen.
- 5 Wait until the MACSQuantify Software is loaded completely. Connect the keyboard included in the delivery. Connect a mouse if desired.

2.5.4 Installation of the MACSQuant® Column

WARNING Read the chapter **Important safety information** in this user manual. Always wear protective gloves and eye wear in order to protect against potential exposure to biohazard.

The MACSQuant instrument is delivered with a column substitute, which must be exchanged for a MACSQuant Column before using the MACS® Enrichment Unit. The MACS Enrichment Unit is integrated in the instrument. Magnetically and fluorochrome-labelled cells are pre-enriched in the MACSQuant Column prior to cell analysis allowing flow cytometric analysis of rare cell populations in a fraction of time. Up to 5×10^6 magnetically labeled cells can be enriched and analyzed in a single step. The entire process of labeling, pre-enrichment and flow cytometric analysis is fully automated. The MACSQuant Column can be used for up to three months before it needs to be replaced. Please keep the column substitute, it can be reinstalled if the MACSQuant Column is no longer needed.

- 1 Open the front access cover of the instrument in order to access the MACS Enrichment Unit and the column substitute / MACSQuant Column.
- 2 Using both hands, hold the top and bottom of the column and pull gently but firmly to remove it from its slot.

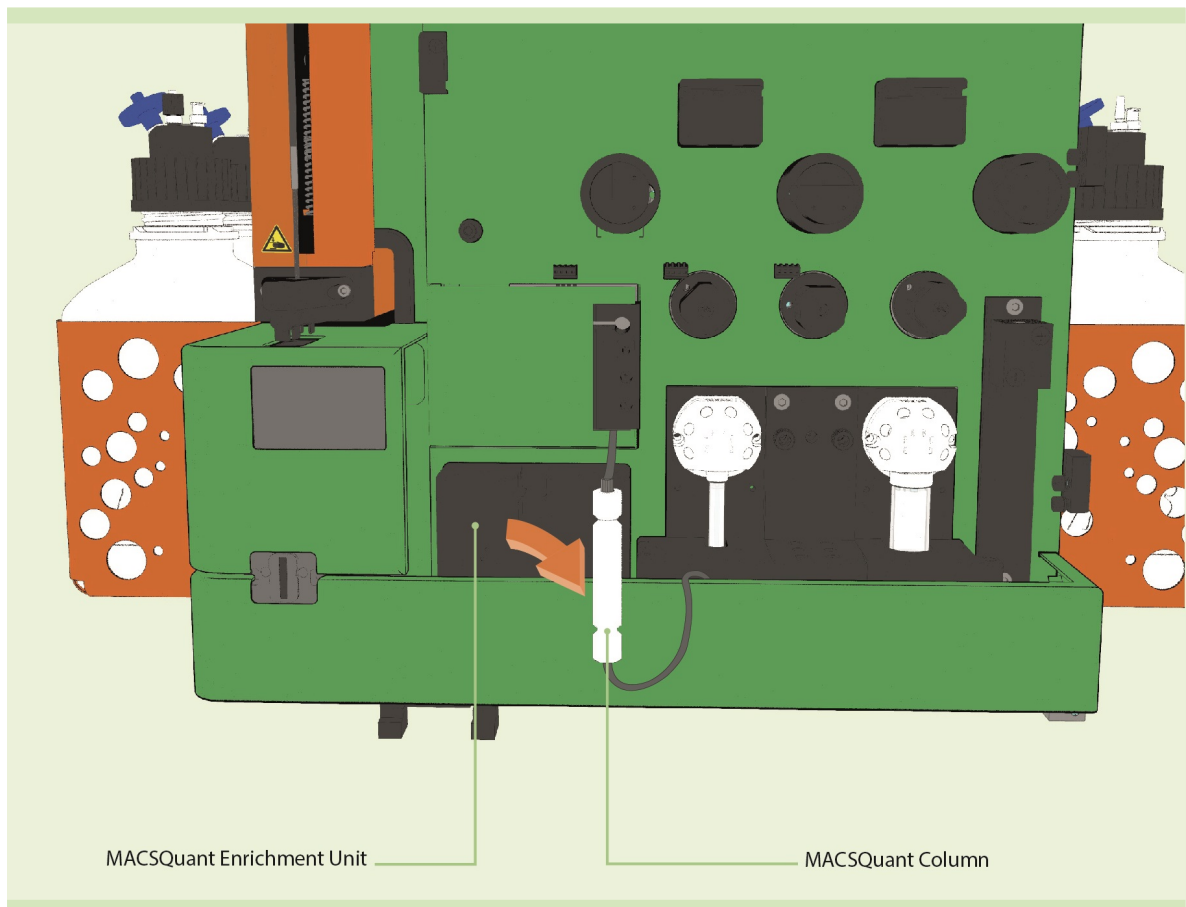

- 3 Hold the column in one hand and gently unscrew the upper column connector counter-clockwise. Tilt the column downwards to empty any liquid into a paper towel placed underneath.

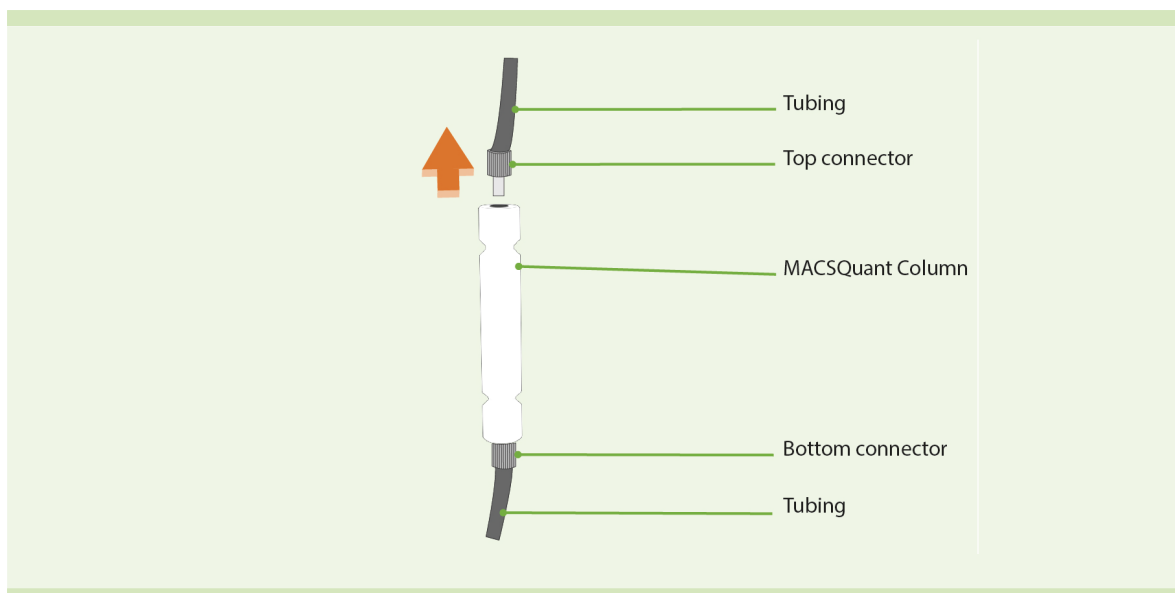

- 4 Unscrew the bottom column connector to remove the column.

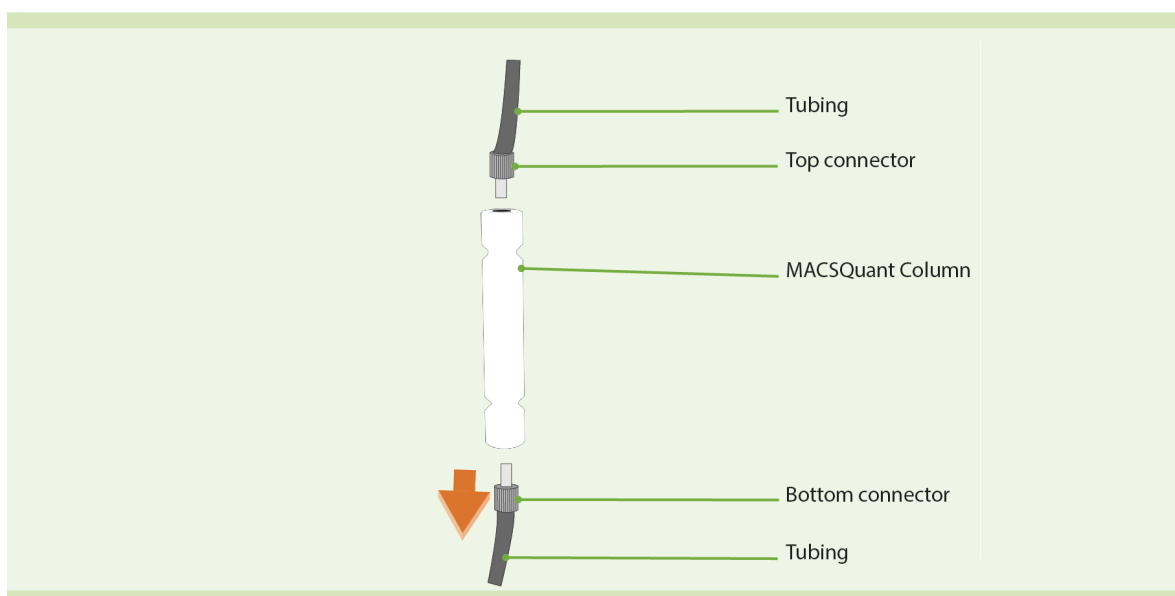

- 5 Screw the bottom column connector into the bottom end of the new column. Please note the right orientation of the column. The top end of the MACSQuant column has a clearly visible inlet, while the metal balls reach further to the bottom end of the column. The column should be inserted only with the visible inlet at the top position.
- 6 Point the column towards the top of the device and screw in the top column connector.
- 7 Align the column so that the top column connector sits on the guide of the magnet cover. Push the column into the slot until you hear a click. Verify that the column is placed in the center of the magnet cover.
- 8 Close the front access cover of the instrument.
- 9 Prime the new column: select the option **Prime column** from the **Tools tab** on the side pane. Refer also to the MACSQuantify Software guide.
- 10 To replace a column, follow the same procedure.

2.5.5 Install the webcam

- 1 Attach the magnetic webcam holder to the side of the instrument.
- 2 Plug in the webcam cable into a free USB port at the rear side of the instrument.
- 3 Place the webcam into its holder.

- 4 The webcam is recognized automatically.

Unplug the webcam during normal operation of the instrument. Use it only during a Live support session.

2.5.6 Install the needle guard

- 1 Check if the needle guard is attached to the robotic needle arm.
- 2 If not, install as depicted below.

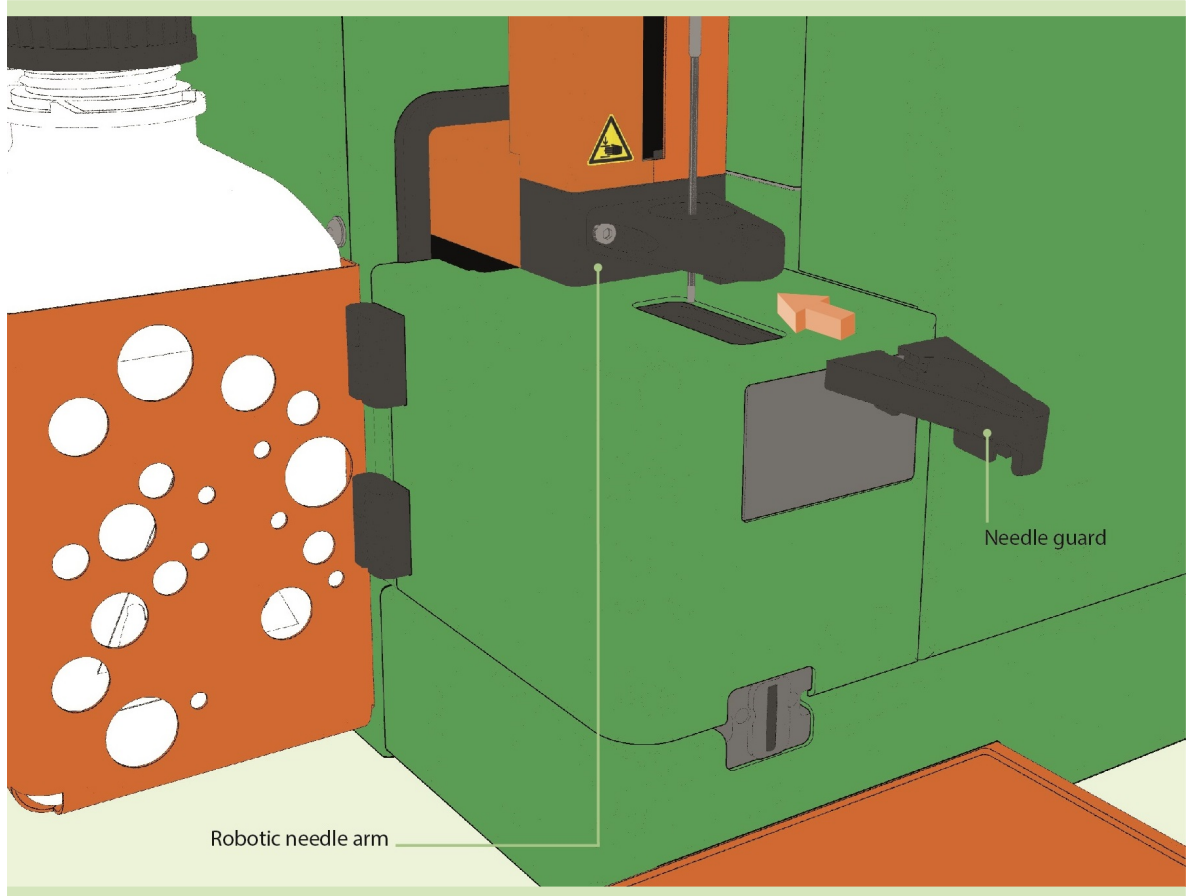

Figure 2.4: Only operate the instrument with attached needle guard.

2.5.7 Install the MACS® MiniSampler Plus

If using the instrument with a MACS® MiniSampler Plus, follow the instructions below. The MACS MiniSampler Plus can be installed to either the autoMACS® Pro or the MACSQuant Instruments (MACS Quant Analyzer 10, Analyzer 16, VYB).

Use a MiniSampler Plus only with one type of instrument. After a MiniSampler Plus has been used with a MACSQuant model, it cannot be used with the autoMACS Pro anymore.

- 1 Switch off the instrument before installing the MACS MiniSampler Plus.
- 2 Remove the transparent protection foil from the lens of the rack detector. Note the position of the MACS MiniSampler Plus slot located at the front of the instrument and the MACS MiniSampler Plus guiding.
- 3 Tilt the MACS MiniSampler Plus.

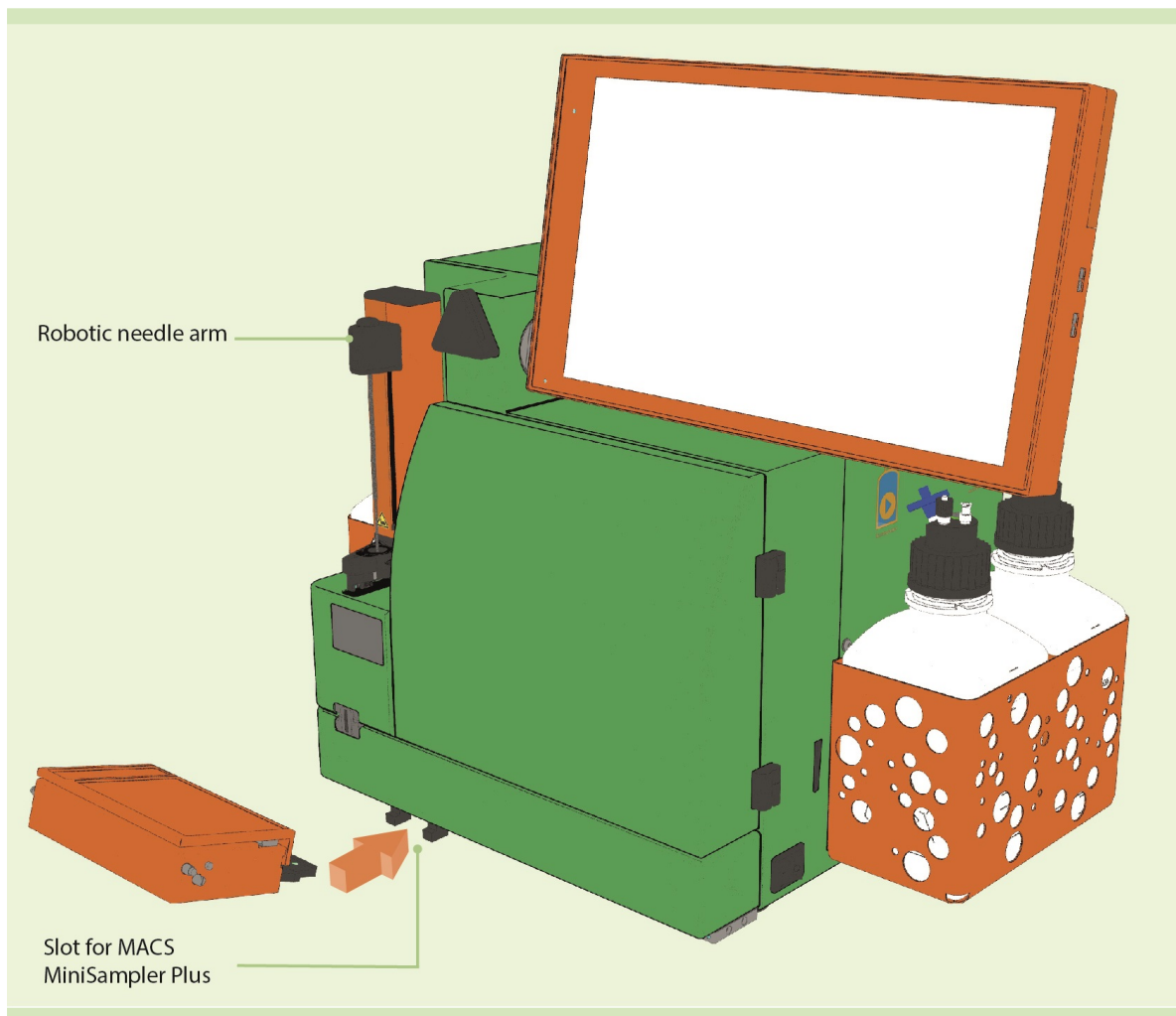

- 4 Slide the guiding into the receiving slot. Keep the MACS MiniSampler Plus in a tilted position until resistance is met.
- 5 Lower the MACS MiniSampler Plus to a horizontal position in order to lock it.

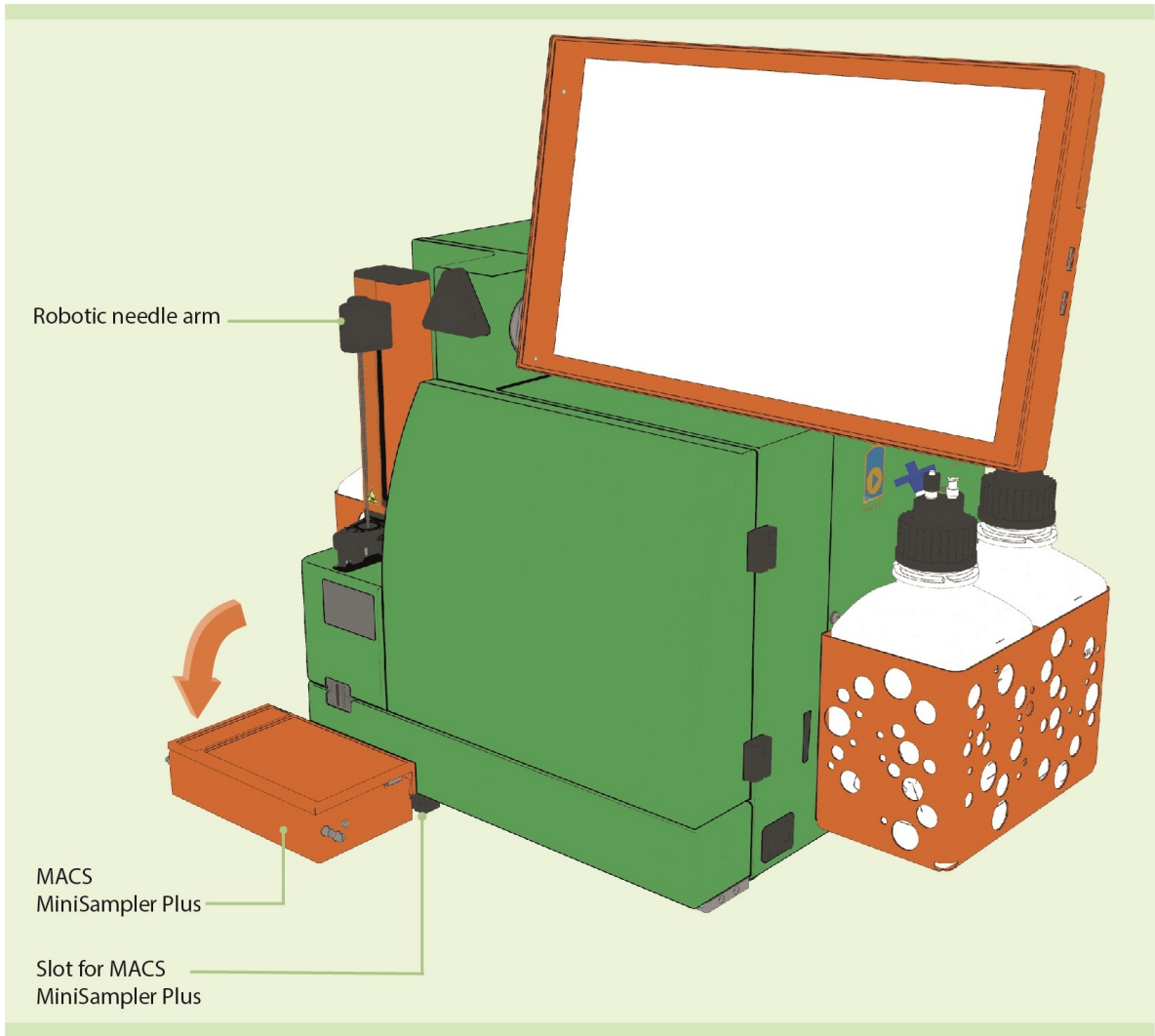

6 Open the front door of the instrument and fix the MACS MiniSampler Plus with the according screw.

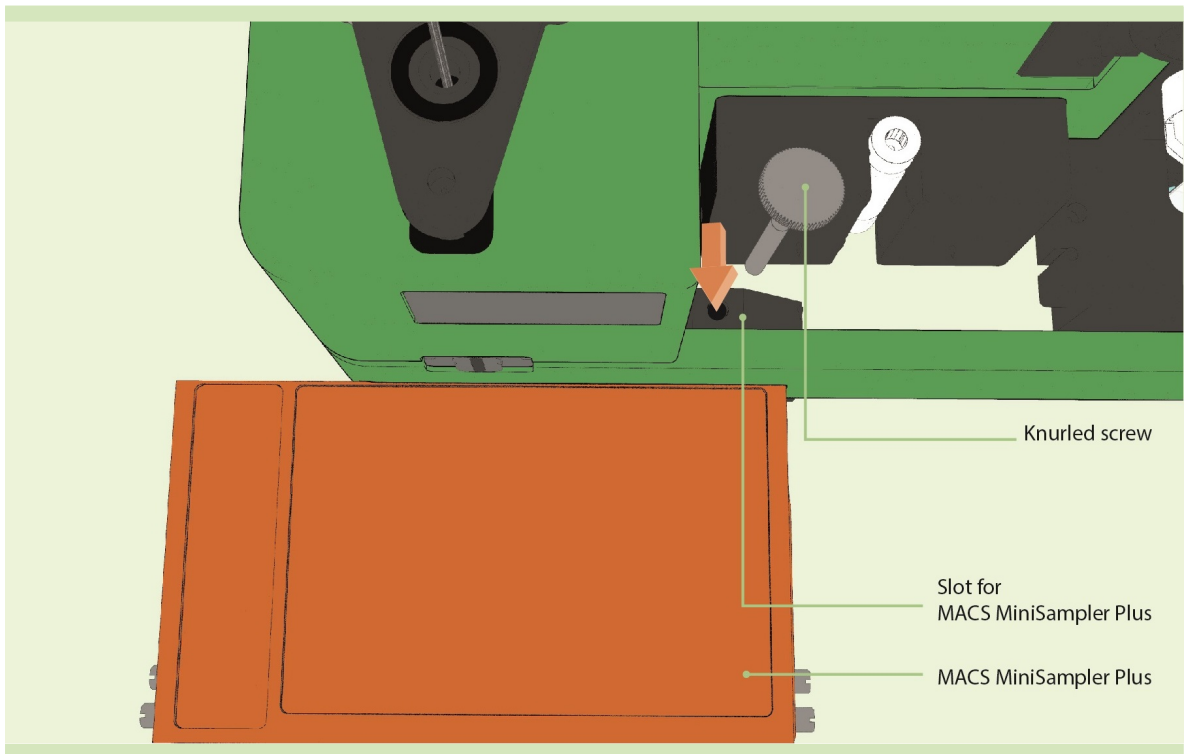

- 7 Close the front door of the Instrument and ensure that the MACS MiniSampler Plus is completely inserted and secured.
- 8 Guide the MACS MiniSampler Plus cable underneath the instrument and connect it to the port labeled **External CAN** at the back of the instrument.

2.5.8 Install the Chill Rack and Universal Reagent Rack

- 1 Install the Universal Reagent Rack onto the MACS MiniSampler Plus into the left recess by snapping the engagement hook into the undercut.

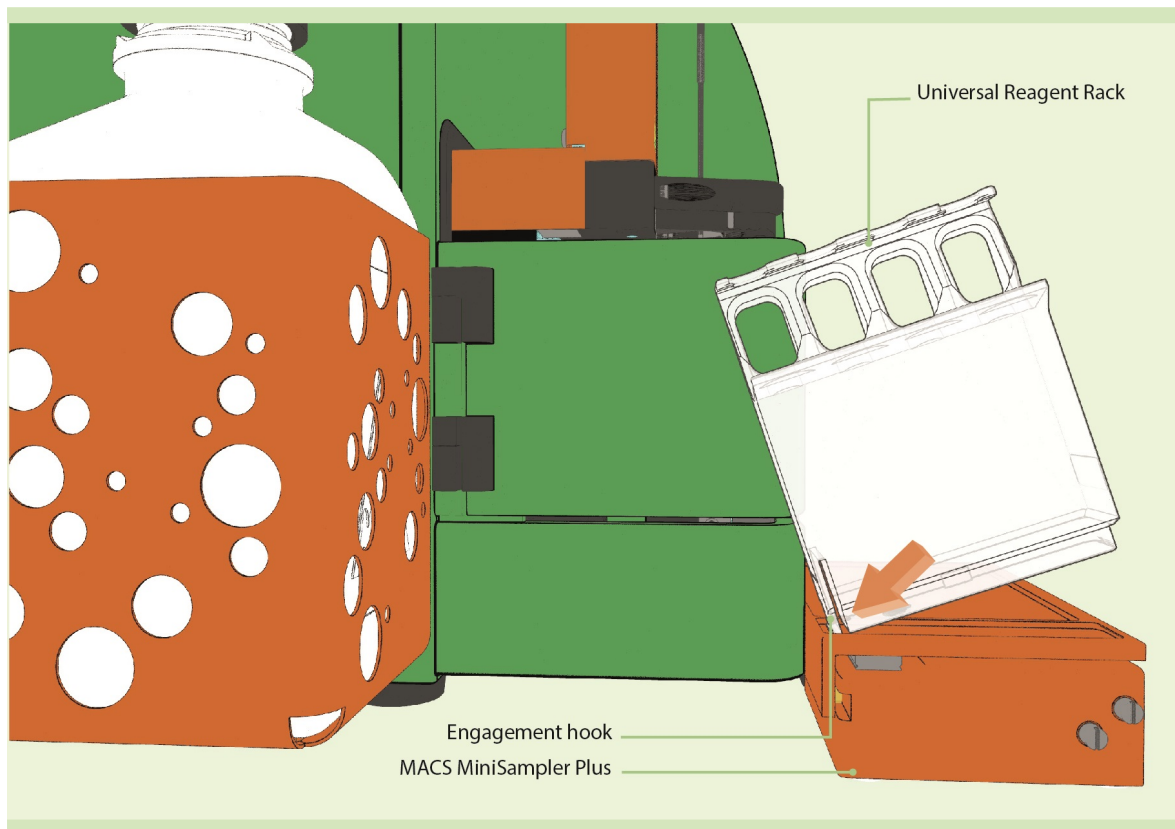

- 2 Place a MACS Chill Rack onto the MACS MiniSampler Plus into the right recess, ensuring that the rack bar code is facing the instrument. If automatic recognition of the tube rack fails, the instrument will display a screen for manual selection of the tube rack. Before confirming the choice, ensure that the rack is placed correctly into the recess.

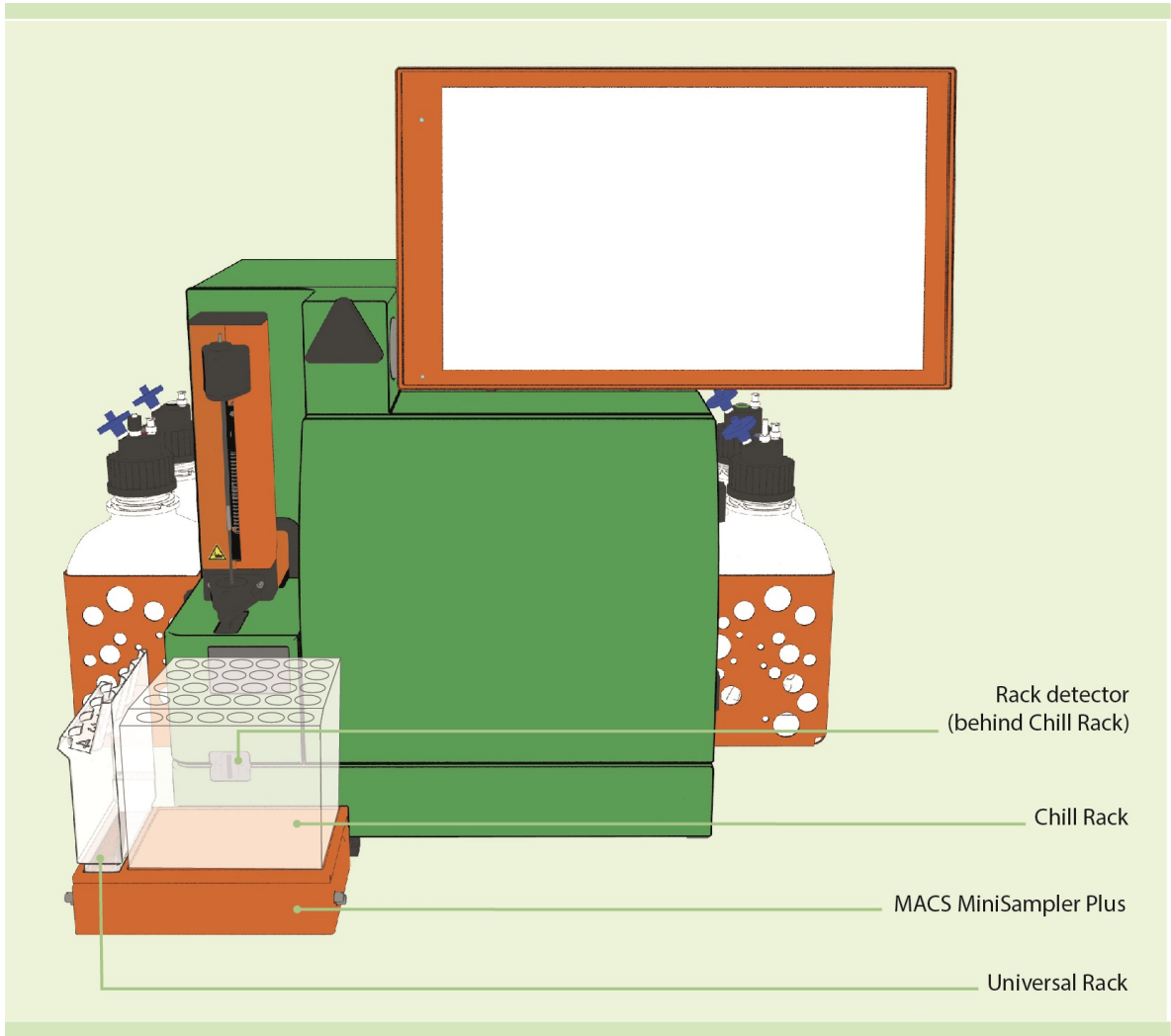

- 3** Note the position of the lid guiding at both sides of the MACS MiniSampler Plus and attach the protective cover. Keep the protective cover attached and closed while the instrument is in operation.

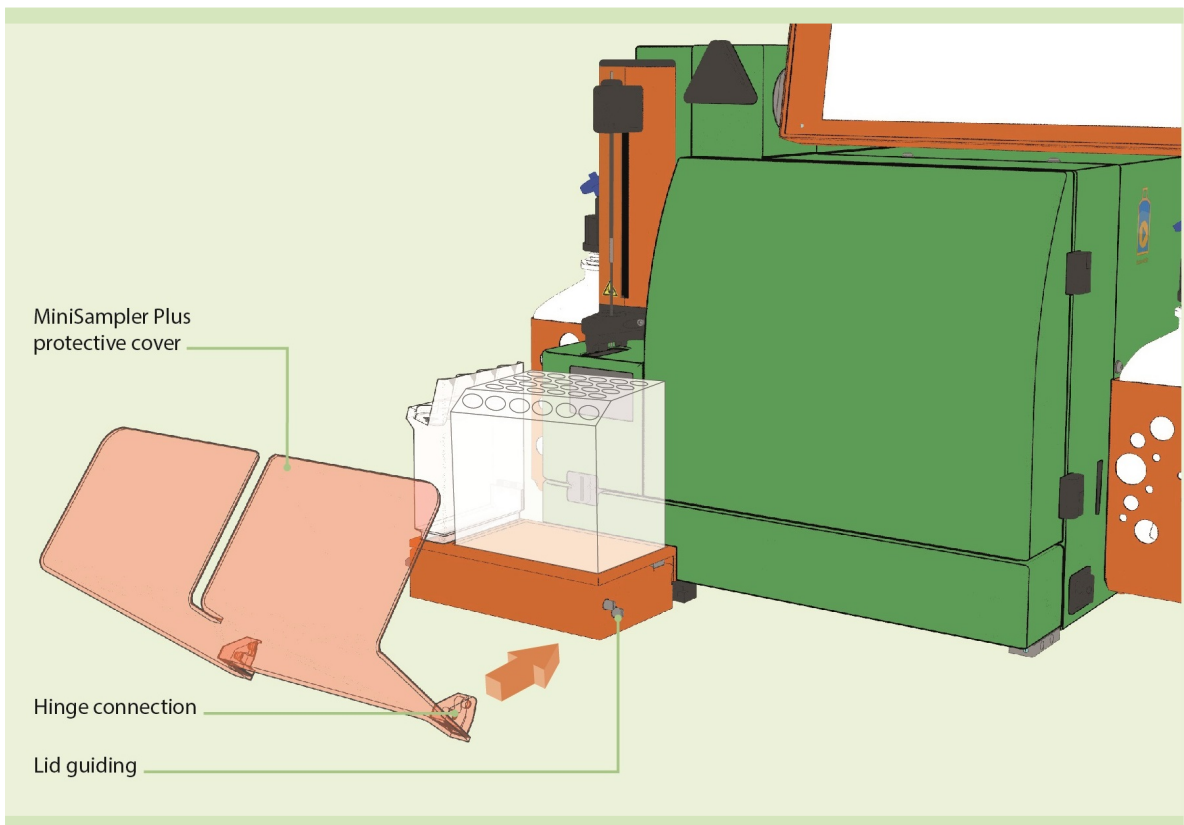

2.5.9 Installation checklist

Please ensure the correct installation of the instrument by the following checklist:

- Note the correct positioning of each fluid bottle and the waste bottle, recognizable by the color code and the symbols. This is crucial for successful analysis.
- Ensure that the correct tubing and fluid sensor cable is attached to the corresponding bottle, and that all tubing connections as well as the bottle closures are fastened. If necessary, tighten loose connections using a wrench.
- Ensure that the fluid bottles are filled and installed correctly. For safe operation of the instrument, all fluid bottles must contain at least 150 mL of the respective solution. In order to prevent contamination of the fluidics system the use of non-sterile buffers and solutions is not recommended. Only use buffers and solutions supplied by Miltenyi Biotec for operation of the instrument. A reproducible and optimal performance of the instrument cannot be guaranteed when the instrument is operated using self-made buffers and/or solutions procured from another manufacturer.
- Make sure that the waste bottle is empty and installed correctly. **WARNING!** When working with biohazardous samples, it is recommended to fill the waste bottle with 100 mL of disinfectant before use. Empty bottles from the Running Buffer, Washing Solution, or Storage Solution may be used as waste bottles only with the appropriate safety label on it. For proper disposal, please follow local regulations and carefully read the chapter Important safety information.
- Open the front door and check that the column substitute or the MACSQuant® Column is installed correctly. Ensure that the tubes are securely fastened to the column and that no part of the visible tubing is pinched or obstructed.
- Ensure that the needle guard is attached to the instrument. **WARNING!** There is a hazard of crushing, shearing, or puncturing bodily parts. Operate only with attached needle guard.

When all points of this installation checklist have been fulfilled, close all covers.

3

Operating the instrument

3.1 Switching on the instrument

- 1 Switch on the instrument by using the main switch on the right side of the instrument. The instrument will be in stand-by mode.
- 2 Touch the touchscreen to power up the instrument.

For a detailed instruction of how to use the MACSQuantify™ Software, refer to the MACSQuantify™ Software User Manual.

3.2 Shutting down

Shut down the software before switching off the instrument. Shut down the software manually, or set the instrument to automatically shut down under certain conditions.

3.2.1 Manual shutdown

- 1 Click the **Main instrument control button** at the upper right corner of the screen.
- 2 Select **Instrument off**. This automatically starts a wash program that lasts for approximately seven minutes. The fluidic system is thoroughly washed with Washing Buffer and finally filled with storage solution.
- 3 At the end of the washing program, the instrument is in standby mode. It can now be switched off, or rebooted by touching the touchscreen.
- 4 Switch off the instrument using the main power switch at the right side of the instrument.

With the **main instrument control button**, the instrument can also be turned into data analysis mode. This will start the washing procedure as well, but allows data analysis in the meantime.

3.2.2 Automatic shutdown

By default, automatic shutdown is enabled. If the instrument is idle for a preset amount of time, it will automatically shut down or, alternatively, switch into **Analysis mode** to elongate diode lifespan of the lasers. Refer to the MACS Quantify™ Software manual for information about the Analysis mode.

- 1 To modify the automatic shutdown settings, log in as an administrator.
- 2 Go to **Edit > Options (default) > Software > Timers**.

- 3 Set the following parameter:
 - Standby timer, the amount of idle time before shutdown begins.
 - Shutdown timer, the incubation time during the shutdown procedure (5 minutes is recommended)
 - Needle priming time, to avoid that the needle runs dry (20 seconds are recommended)
- 4 Set the **Shutdown default behavior** to **Instrument off**.
- 5 Switch off the instrument using the main power switch at the right side of the instrument.

The **Shutdown default behavior** can also be set to **Analysis mode**.

3.3 Long-term storage

If the instrument is not in use for a longer time, flush the fluidics system every two weeks to prevent blockages.

- 1 Switch on the instrument.
- 2 Run a **Flush program**.
- 3 Shut down the instrument.

4

Calibration

Before using the MACSQuant® Instrument for the first time, calibrate the hardware. Calibrate also the photomultiplier tubes (PMTs) of the instrument. In order to calibrate the MACSQuant Instrument, the user must be familiar with the MACSQuantify™ Software. It is highly recommended that hardware calibration is only performed by an administrator who has been trained by Miltenyi Biotec. Refer to the MACSQuantify™ Software manual and/or the help function of the MACSQuant Instrument for an introduction to the MACSQuant Instrument user interface and a detailed description of the instrument settings.

4.1 Calibrating the sample uptake unit

4.1.1 Calibrating the robotic needle arm

During calibration, the robotic needle arm moves between the samples and the washing station with its sample injection port and washing port. Ensure that the robotic needle arm can move freely and that no object is obstructing it.

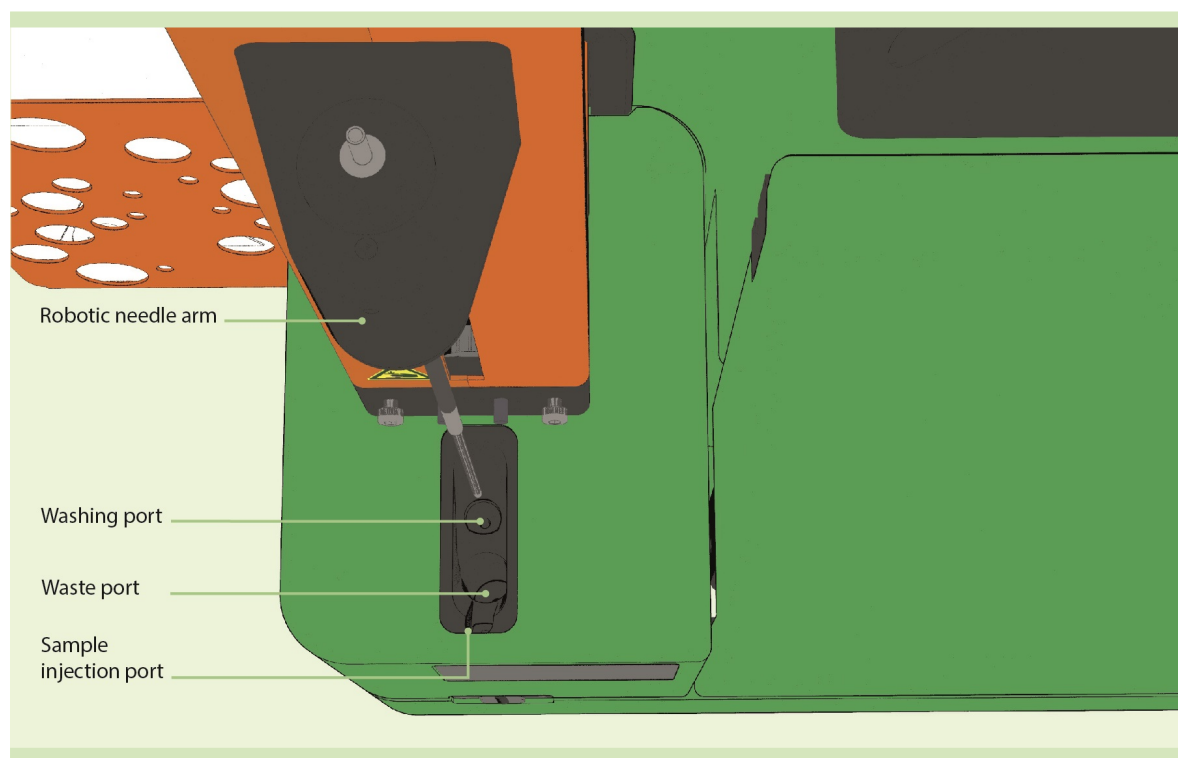
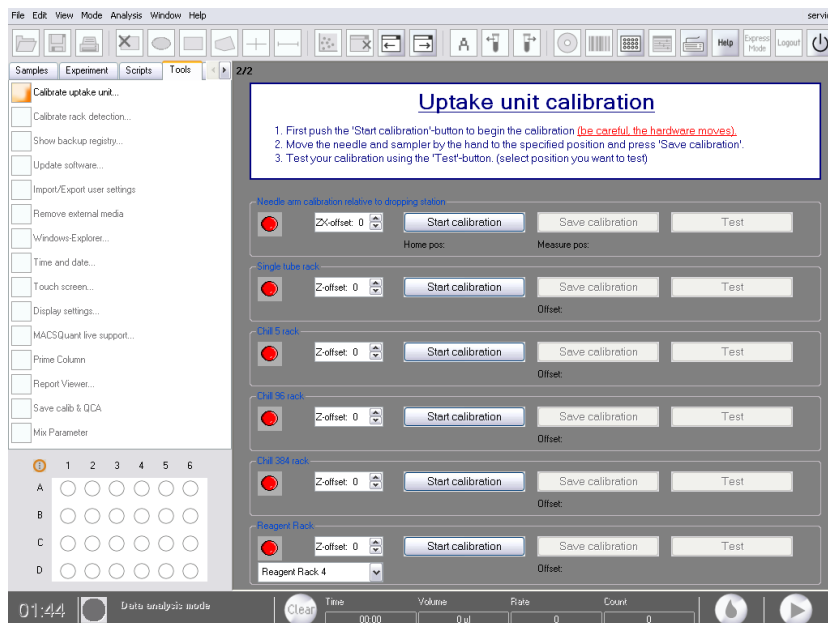
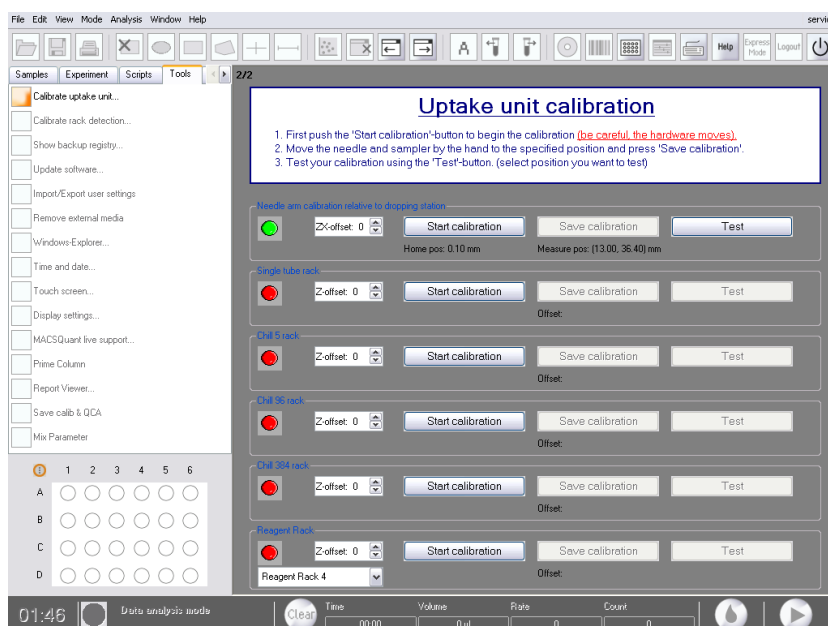

Figure 4.1: The washing station, top view (needle guard not shown).

- 1 Click on the **Tools tab** on the side pane of the MACSQuantify™ Software and check the **Calibrate uptake unit** box. A red closed circle indicates that the respective uptake component is not calibrated.



- 2 Click **Start** calibration under the heading **Needle arm calibration relative to** washing **station**. The robotic needle arm will move toward the washing station before being inserted into the sample injection port. If the uptake needle pops out of the robotic needle arm holder, a system failure is caused and a prompt screen to reinitialize appears. Reinsert the uptake needle, adjust the robotic needle arm appropriately, and click **OK** to confirm.
- 3 Manually adjust the robotic needle arm in order to position the uptake needle over the center of the sample injection port.
- 4 Gently lower the robotic needle arm manually into the sample injection port makes first contact with the bottom of the orifice. The uptake needle must not pop out of the needle holder and always remain perpendicular to the horizontal plane. Do not bend the needle or insert it diagonally.
- 5 In the field ZX-offset, enter 30.
- 6 Click **Save** calibration.
- 7 In the field ZX-offset, set the value back to 0 and confirm with the **Enter** key.
- 8 The closed green circle indicates that the calibration is completed. Click **Test** to confirm that the correct coordinates are saved.



4.1.2 Calibrating the Single tube rack

- 1 Attach the Single tube rack with desired sample tube to the instrument as described in **Install the Single tube rack on page 65**.
- 2 Click **Start calibration**. The robotic needle arm will automatically move forward and insert the uptake needle into the single tube. The uptake needle should be positioned at the center of the tube (i.e. equidistant from the tube edges) almost touching the tube bottom (i.e. only a fraction of a millimeter from the bottom of the tube). To check the uptake needle position, gently wiggle the tube to ensure that there is a small amount of movement.
- 3 If this is not the case, carefully adjust the robotic needle arm accordingly.
- 4 Click **Save calibration**. The closed green circle indicates that the calibration is completed. Click **Test** to confirm that the correct coordinates are saved.

4.1.3 Calibrating the Chill 5 Rack

For the correct usage of the MACS® MiniSampler Plus, please calibrate the Chill 5 Rack.

- 1 Attach the MACS MiniSampler Plus to the MACSQuant Instrument as described in .
- 2 Click on the **Tools tab** on the side pane of the MACSQuantify™ Software and check the **Calibrate uptake unit** box. Red closed circles indicate that the uptake components are not calibrated.
- 3 Place a Chill 5 Rack onto the MACS MiniSampler Plus or and place an empty 5 mL tube in position D6.
- 4 Click **Start calibration**. The robotic needle arm will automatically move forward and insert the uptake needle into the tube in the position **D6** of the **Chill 5 Rack**. The uptake needle should be positioned at the center of the tube (i.e. equidistant from the tube edges) almost touching the tube bottom (i.e. only a fraction of a millimeter from the bottom of the tube). To check the uptake needle position, gently wiggle the tube to ensure that there is a small amount of movement.
- 5 If this is not the case, carefully adjust the robotic needle arm accordingly.
- 6 Click **Save calibration**. The closed green circle indicates that the calibration is completed. Click **Test** to confirm that the correct coordinates are saved. The MACSQuant Instrument will automatically test selected positions.

4.1.4 Calibrating the 96-well plate

- 1 Click on the **Tools tab** on the side pane of the Software and check the **Calibrate uptake unit** box. Red closed circles indicate that the uptake components are not calibrated.
- 2 Click the **Experiment tab** in the side pane of the Software and select the 96-well format from the Rack pull-down menu. If the 96-well is not selected, the MACSQuant® Instrument will display a prompt screen.
- 3 Place a Chill 96 Rack onto the MACS® MiniSampler Plus and load an empty 96-well plate.
- 4 Click **Start calibration**. The robotic needle arm will automatically move forward and insert the uptake needle into the well position H12 of the 96-well plate.
- 5 The uptake needle should be positioned at the center of the well (i.e. equidistant from the well edges) almost touching the well bottom (i.e. only a fraction of a millimeter from the bottom of the well). To check the uptake needle position, gently wiggle the plate to ensure that there is a small amount of movement.
- 6 If this is not the case, carefully adjust the robotic needle arm accordingly.
 - a) If the needle is on the left corner of the well, first push the MACS MiniSampler Plus from the right, such that the needle is on the right corner of the well. Then proceed with b)

b) If the needle is on the right corner of the well, push the MACSQuant MiniSampler Plus from the left to reach the center position of the needle in the well. The last movement of the MACS MiniSampler Plus must be from the left.

c) If the needle is on the rear corner of the well, first move the needle arm to the front, such that the needle is on the front corner of the well. Then proceed with d)

d) If the needle is on the front corner of the well, move the needle arm to the front to reach the center position of the needle in the well. The last movement of the needle arm must be from the front.

e) Push the needle down, almost touching the well bottom (i.e. only a fraction of a millimeter from the bottom of the well). To check the uptake needle height, gently wiggle the plate to ensure that there is a small amount of movement.

- 7 Click **Save calibration**. The closed green circle indicates that the calibration is completed. Click **Test** to confirm that the correct coordinates are saved. The instrument will automatically test selected positions.

4.1.5 Calibrating the MACSPlex Filter Plate

- 1 Click on the **Tools tab** on the side pane of the Software and check the **Calibrate uptake unit** box. Red closed circles indicate that the uptake components are not calibrated.
- 2 Click the **Experiment tab** on the sidebar of the MACSQuantify Software and select **MACSPlex Filter Plate** from the **Rack** pull-down menu. If the MACSPlex Filter Plate is not selected, the MACSQuant® Instrument will display a prompt screen.

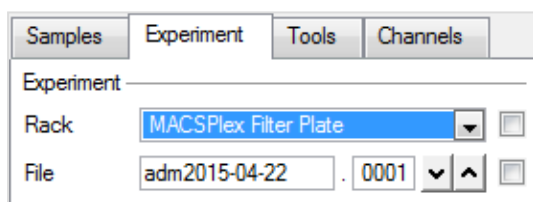

- 3 Place a Chill 96 Rack onto the MACS MiniSampler Plus and load an empty MACSPlex Filter Plate.
- 4 Click **Start** calibration. The robotic needle arm will automatically move forward and insert the uptake needle into the rack position H12 of the MACSPlex Filter Plate. The uptake needle should be positioned at the center of the well (i.e. equidistant from the well edges) almost touching the well bottom (i.e. only a fraction of a millimeter from the bottom of the well). To check the uptake needle position, gently wiggle the plate to ensure that there is a small amount of movement.
- 5 If this is not the case, carefully adjust the robotic needle arm accordingly.
- 6 Click **Save** calibration. The closed green circle indicates that the calibration is completed. Click **Test** to confirm that the correct coordinates are saved. The MACSQuant Instrument will automatically test selected positions.

4.1.6 Calibrating the MACS® Reagent Rack 4

- 1 Click on the **Tools tab** on the side pane of the Software and check the **Calibrate uptake unit** box. Red closed circles indicate that the uptake components are not calibrated.
- 2 Place the MACS® Reagent Rack 4 onto the MACS MiniSampler Plus as described in **Install the MACS® MiniSampler Plus on page 69**.
- 3 Load an empty reagent vial in position 4 of the MACS Universal Rack and close the protective cover.
- 4 Click **Start calibration**. A dialog box will prompt you to ensure that the MACS Universal Rack is indeed correctly placed and that the Single tube rack is removed.

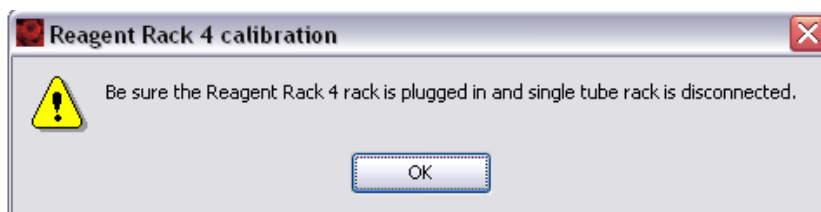

- 5 Confirm the dialog box by clicking **OK**. The robotic needle arm will automatically move forward and insert the uptake needle into the reagent vial position 4. If this is not the case, carefully adjust the robotic needle arm accordingly.
- 6 Click **Save calibration**. The closed green circle indicates that the calibration is completed. Click **Test** to confirm that the correct coordinates are saved. The MACSQuant Instrument will automatically test selected vial positions.

4.1.7 Calibrating the Universal Reagent Rack

- 1 Click on the **Tools tab** on the sidebar of the Software and check the **Calibrate uptake unit** box. Red closed circles indicate that the uptake components are not calibrated.
- 2 Place the Universal Reagent Rack onto the MACS MiniSampler Plus.
- 3 Load an empty reagent vial in position 4 (front-most position) of the Universal Reagent Rack.
- 4 Click **Start calibration**. A dialog box will prompt you to ensure that the Universal Reagent Rack is installed correctly and that the Single tube rack is removed.
- 5 Confirm the dialog box by clicking **OK**. The robotic needle arm will automatically move forward and insert the uptake needle into the reagent vial position 4. If this is not the case, carefully adjust the robotic needle arm accordingly.
- 6 Click **Save calibration**. The closed green circle indicates that the calibration is completed. Click **Test** to confirm that the correct coordinates are saved. The MACSQuant Instrument will automatically test selected vial positions.

4.1.8 Calibrating the custom 96 racks

If 96-well plates of different format (e.g. deep well or round bottom) are used, they might have a different distance from the bottom of the rack to the bottom of the well. In order to pick the samples correctly, individual "custom" racks can be defined for each required rack format.

- 1 Click on the **Tools tab** on the side pane of the Software and check the **Calibrate uptake unit** box. Red closed circles indicate that the uptake components are not calibrated.
- 2 Click the **Experiment tab** on the sidebar of the MACSQuantify Software and select **Chill 96 rack** from the Rack pull-down menu.
- 3 Proceed as described for standard 96 (see **Calibrating the 96-well plate on page 79**).

4.2 Calibrating the rack detection

4.2.1 Calibrating the Single Tube rack detection

- 1 Click on the **Tools tab** on the side pane of the MACSQuantify Software and check the **Calibrate rack detection** box. Red closed circles indicate that the components are not calibrated.
- 2 Click **Start** calibration under the heading **Single tube rack detection**.

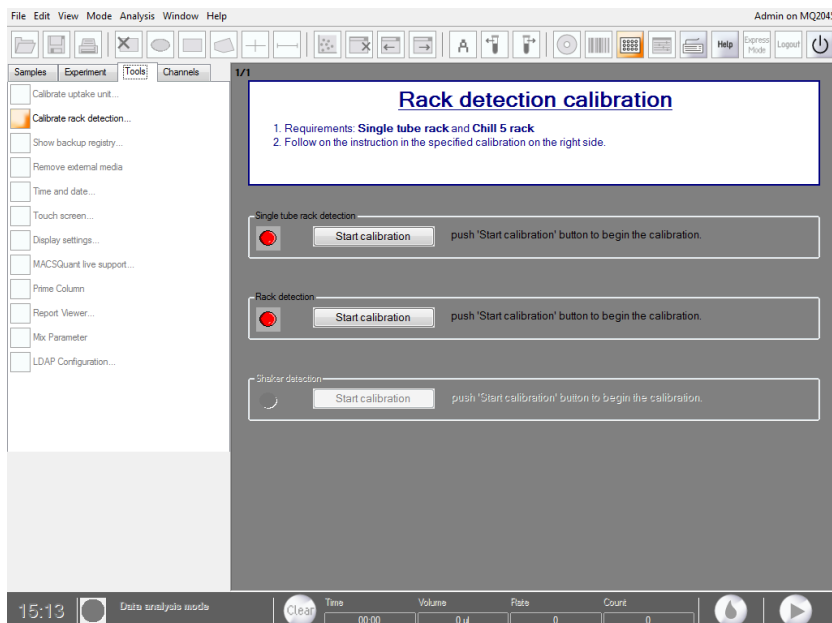

- 3 The closed green circle indicates that the calibration is completed. After all calibrations are completed, the instrument can be switched into acquisition mode.

4.2.2 Calibrating the rack detection

This step is required for the automatic detection of Chill 5, 15, and 50 Racks by the MACSQuant® Instrument if using the MACS® MiniSampler Plus.

- 1 Attach the MACS MiniSampler Plus to the MACSQuant Instrument.
- 2 Click the **Experiment** tab on the sidebar of the MACSQuantify™ Software and select **Chill 5 tube rack** from the **Rack drop-down menu**. If the adjacent box is activated, the rack will be detected automatically.
- 3 Deactivate this box before proceeding.

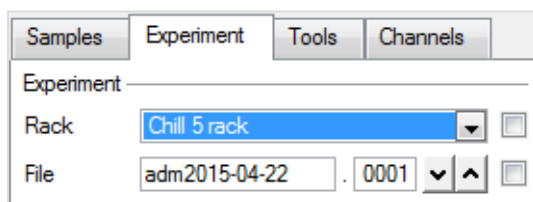

- 4 Place a Chill 5 Rack onto the MACS MiniSampler Plus and click **Start calibration** under the heading Rack detection.

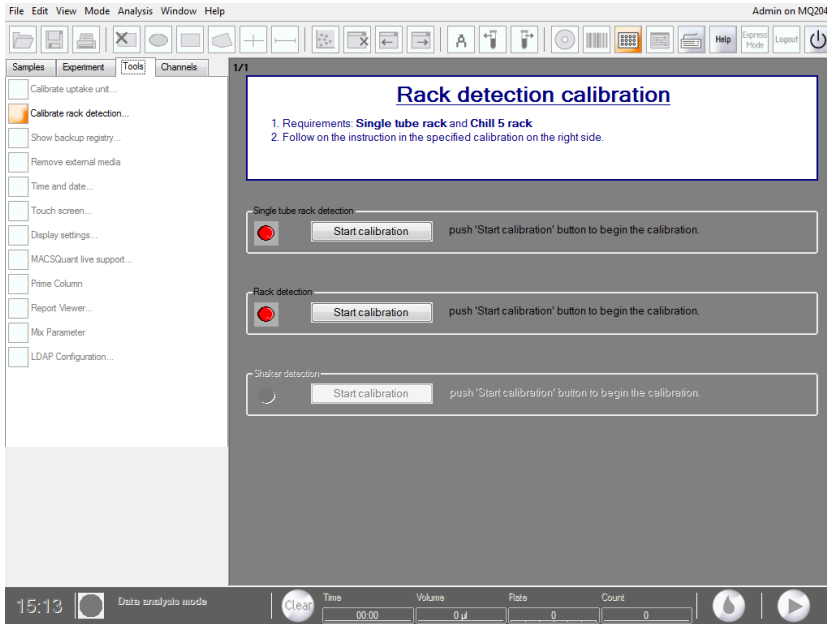

- 5 The MACSQuant Instrument will move the Chill 5 Rack in order to check the 2D code reader. The closed green circle indicates that the calibration is completed. After all calibrations are completed, the instrument can be switched into acquisition mode.

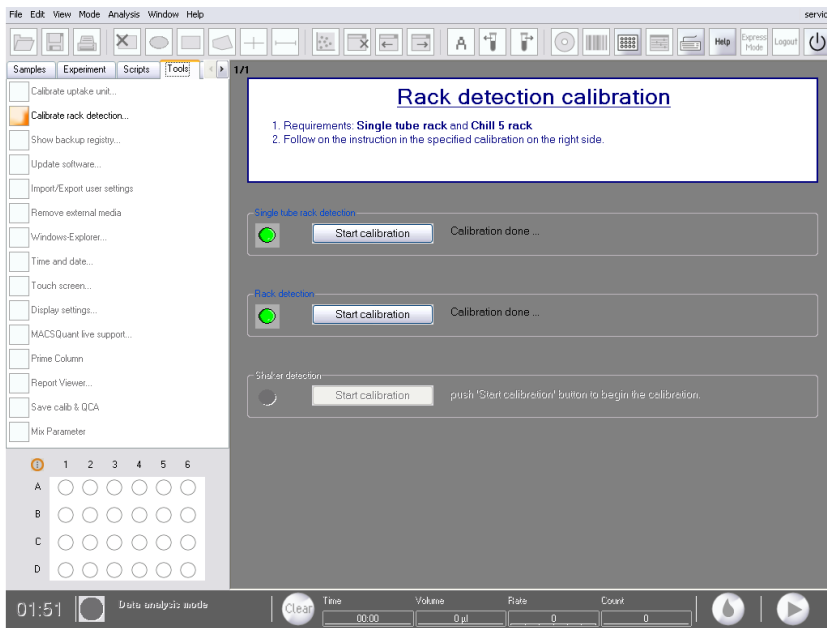

5

Hardware monitor

5.1 Hardware monitor

5.1.1 Fluidics

The fluidics tab in the hardware monitor displays the pumps and valves in the live status, as well as the status of the fluid bottles.

Component	Further information
Fluid bottle monitor	Displays buffer/solution levels in real time
Pump monitor	Displays the status of the waste (W), air (A), and fill (F) pumps
Separation unit monitor	Displays the status of the MACSQuant Column and MACS Enrichment Unit
Valves 1–3 monitor	Displays the position of the valves for the MACSQuant Column: C = closed, O = open, green = in use
Valves 4–6 monitor	Displays the position of the general fluidics system valves
Syringe drive monitor	Displays the position of the dilutor
Sensor monitor	Displays the general system pressure and fluid reservoir levels.

Table 5.1: Panels of the **Fluidics** tab.

The waste (W), air (A), and fill pump symbols (F) are illuminated in green when active. Active separator valves (Valves 1-3) are indicated in green, defective rotary valves in red. Valve status is indicated by o for open and c for closed. The fluid bottles in the hardware monitor as well as on the instrument will be illuminated in red when empty; the waste bottle will be illuminated in red when full.

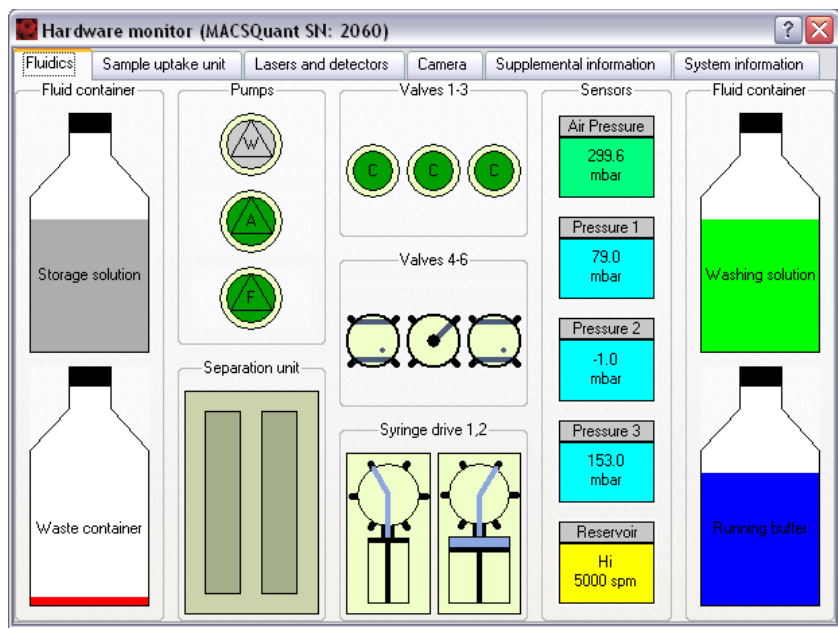

Figure 5.1: Real-time Hardware monitor of the fluidics components. Specifications may vary between instrument models (refer to **Technical data and specifications pageref**).

5.1.2 The Sample uptake unit

The sample uptake tab indicates the status of the robotic needle arm as well as whether the MACS® MiniSampler Plus is connected or not. The relative position of the robotic needle arm is listed in the lower left box as well as whether the Single tube rack is connected or not.

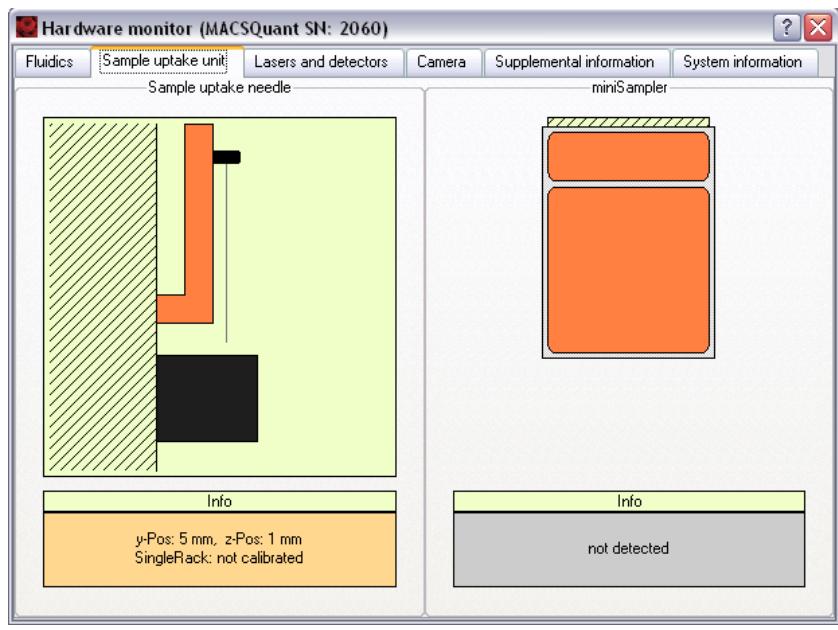

Figure 5.2: Real-time hardware monitor of the sample uptake arm.

5.1.3 Lasers and detectors

The lasers and detectors tab display the status of the optical bench. It is possible to monitor the status of each laser fluorescence channel. The temperature, fan speed, PMT voltage, and annotated path of each laser is shown. A status overview of the optical bench is schematically represented. The bench temperature is kept between 33 °C and 37 °C. Therefore, the fan speed is regulated automatically depending on the ambient room temperature and internal temperature of the MACSQuant Instrument. Please note that the temperature for the lasers should be between 10 °C and 45 °C. In case of errors, please contact Miltenyi Biotec Technical Support.

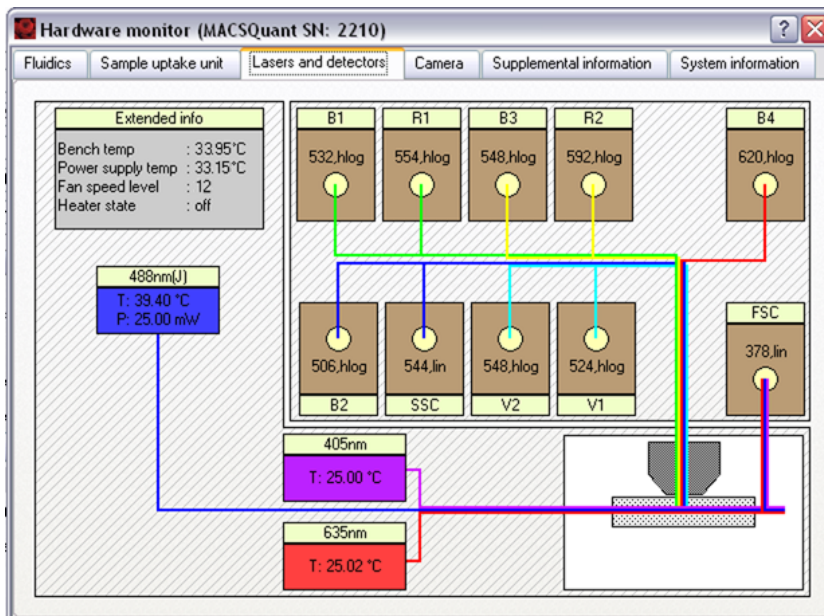

Figure 5.3: Real-time Hardware monitor of the optical bench. Specifications may vary between instrument models (refer to **Technical data and specifications pageref**).

5.2 Instrument status LEDs

The MACSQuant® Instrument is equipped with LEDs, illuminating each bottle to indicate the status of the instrument in Acquisition mode. If the fluid bottles are not illuminated, the MACSQuant Instrument is in data analysis mode and the lasers are off.

Bottle illumination	Description
Green	The MACSQuant Instrument is ready to measure, liquid levels are sufficient, and the instrument is primed. Please note that the lasers can take up to 30 minutes to warm-up after performing the initial instrument priming.
Yellow	The MACSQuant Instrument reports sensor error. Please ensure that the sensor is correctly attached to the bottle.
Red	Liquid level error or general instrument error. The liquid levels are too low in a particular bottle or that the waste bottle is full. The blinking red light will indicate which bottle needs to be tended to. Additionally, a message on the Instrument status bar will specify the instrument error. All bottles can be replaced during a measurement.
Blue	Indicates normal instrument function during sample processing, or that the instrument is busy.

Table 5.2: Color code of the fluid bottle illumination on the MACSQuant Instrument.

6

Live Support

6.1 The MACSQuant® Live Support

MACSQuant® Live Support is a real-time diagnostic service provided by Miltenyi Biotec Technical Support. Highly trained MACSQuant Specialists can be reached in real-time to assist with any queries you may have. A webcam is provided for communication with the MACSQuant Live Support, which is attached via USB connection to the MACSQuant Instrument. The webcam is installed to a free USB port at the back of the instrument and detected automatically by the software. During normal operation, the webcam should not be installed on the instrument. Please note that the MACSQuant Instrument must be connected to the internet in order to use the MACSQuant Live Support.

- 1 Click on the **Tools tab** in the **Side pane**.
- 2 Select **MACSQuant Live Support** to access remote assistance.
- 3 Complete all fields and detail any queries you may have using the **Message/Question box**.
- 4 Click **Submit** to commence MACSQuant Live Support.

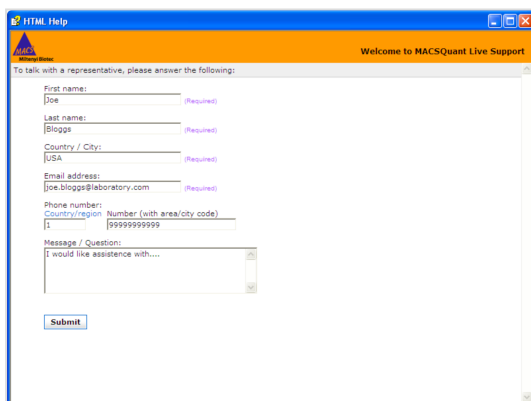

The screenshot shows a web browser window titled "HTML Help" with a sub-header "Welcome to MACSQuant Live Support". The main content area contains a form with the following fields and values:

- First name: Joe (Required)
- Last name: Bloggs (Required)
- Country / City: USA (Required)
- Email address: joe.bloggs@laboratory.com (Required)
- Phone number: Country/region: 1, Number (with area/city code): 9999999999
- Message / Question: I would like assistance with....

A "Submit" button is located at the bottom left of the form.

7

Maintenance

7.1 Decontaminating the instrument

If the instrument has been used to process biohazardous samples, the fluidics system is to be decontaminated by running the standard shutdown sequence. It is recommended to use the appropriate disinfectant for the potential pathogen. Refer to section **Excessive debris is present in acquisition**, page 1 if you would like to perform the **Clean program**. Use tissues or swabs to decontaminate surfaces. The uptake needle of the robotic arm and the surface of the instrument shall be decontaminated upon contact with biohazardous samples.

7.2 Exchanging fluid bottles

- 1 Install one bottle at a time. Remove the bottle to be exchanged from the bottle holder
- 2 Place a new, sealed bottle into the orange bottle holder. Please note the corresponding color-coding.
- 3 Unscrew the lid of the new fluid bottle.
- 4 Remove the bottle closure from the old bottle and install it on the new bottle. Do not disconnect the color-coded tubing and sensor cable from the bottle closure. Take care not to invert the bottle closures, as this could cause liquid to enter the hydrophobic air filter.

7.3 Exchanging the MACSQuant® Column

The MACSQuant® column should be exchanged every three months or replaced with the column substitute after three months.

- 1 Open the front access cover of the MACSQuant instrument in order to reach the MACS® Enrichment Unit and the column substitute or the MACSQuant Column, respectively.
- 2 Using both hands, hold the top and bottom of the column and pull gently to remove it from its slot.
- 3 Hold the column in one hand, and gently unscrew the upper column connector counter-clockwise. Tilt the column downwards to empty any fluid into a paper towel placed underneath.
- 4 Unscrew the bottom column connector to remove the column.
- 5 Screw the bottom column connector into the bottom end of the new column. Please note the right orientation of the column. The top end of the MACSQuant Column has a clearly visible inlet, while the metal balls reach further to the bottom end of the column.
- 6 Point the column towards the top of the device and screw in the top column connector.
- 7 Align the column so that the top column connector sits on the guide of the magnet cover. Push the column into the slot. A clear click can be perceived. Verify that the column is placed in the center of the magnet cover.
- 8 Close the front access cover.
- 9 Prime the new column: Go to the **Tools tab** in the side pane of the MACSQuantify™ Software. Please refer to the software guide for further information.

7.4 Exchanging hydrophobic air filters

Hydrophobic air filters are attached to the bottle closures to vent the liquid bottles and the fluidic system. To avoid clogging of the filters and to prevent contamination of the liquids, exchange the hydrophobic air filters if they come into contact with liquid. To avoid clogging due to deposition of dust, exchange filters once a year. Please use only hydrophobic air filters from Miltenyi Biotec.

- 1 To exchange the air-filter of the fluidics system, remove the Single tube Rack or MACS® MiniSampler Plus if installed.
- 2 Open the right front cover.
- 3 Exchange the filter.
- 4 Re-mount Single tube Rack or MACS MiniSampler Plus if desired.

7.5 Long-term storage of the instrument

The instrument should be run every two weeks in order to prevent clogging. If the instrument is not in use, turn on the instrument every two weeks and switch it into acquisition mode. During the priming procedure, the fluidics will be flushed. After the instrument has been primed and all system checks have been performed, shut down the instrument manually as explained in section **Manual shutdown**, page 1.

7.6 Cleaning programs

Cleaning programs	Description
Rinse	Rinses the needle with washing solution. To start, click on the Rinse icon on the status bar.
Clean	Cleans the needle and cuvette/flow cell with 0.25 mL 1% hypochlorite solution.
Flush	System backflush rinse. To be used if a blockage of the system occurs. To start the Flush program , right-click on the Rinse icon and click on the Flush icon .

Table 7.1: Cleaning programs available for the MACSQuant® Instruments.



Figure 7.1: To access **Clean** or **Flush**, right-click on **Rinse**.

8

Troubleshooting

8.1 Column leakage

- 1 If a freshly installed MACSQuant® Column shows signs of leakage, check if the column is installed properly. Check also that the column is not broken or cracked. The column should be inserted correctly into the column connector and fastened to the point of resistance. If this not the case, loosen the column connector, insert the column correctly, and tighten the connector.
- 2 If the column leakage persists, unscrew the column and check if the connectors of the columns are damaged. If this is the case, exchange the leaking column with a new one.
- 3 If the problem still persists, contact Miltenyi Biotec Technical Support.

8.2 Syringe pump leakage

Depending on the level of use, the syringe pumps should be cleaned every 1 to 3 months. Correct overnight and long-term storage assures that no salt deposits accumulate in the syringe pumps, which could cause wear of the pump seal. The syringe pump should not run dry at any time. This damages the pump seal. In case of leakage of the syringe pump, turn off the instrument and check the connection between the syringe pump and the valve. If it is loose, tighten it. If the leakage persists, contact Miltenyi Biotec Technical Support to replace either the pump syringe or the pump seal.

8.3 Air bubbles during measurement / no event acquisition

Check for leakage within the fluidics and tubing system and perform a rinse program. Also, ensure that the sheath particle filter is devoid of air. Ensure that the needle calibration was performed correctly. Furthermore, check that the tubes connected to the bottle closures are tightly sealed. If the problem persists, contact Miltenyi Biotec Technical Support.

8.4 Excessive debris is present during acquisition

- 1 Check all fluidics to ensure that all tubes are connected properly. Ensure that the sheath particle filter is devoid of air.
- 2 Click the **Rinse button** in the Instrument status bar. Perform this twice.
- 3 If this does not work, try to clean the system by using the **Clean** and/or **Flush program**. To access the **Flush** program, right-click on the **Rinse button**. Click the **Clean button** to perform a system clean with 1% hypochlorite solution. Follow the instructions in the dialog box that appears and place the required bleach solution in the Single tube rack. The Single tube rack must be attached and selected in the **Experiment tab** in order perform a **Clean program**. The **Flush program** will perform a system backflush. This process will take approximately 16 minutes.

8.5 Touchscreen remains dark

If the touchscreen remains dark, check if the power cord is plugged in and the power supply is switched on. If the instrument is switched on. If the instrument is switched on and the touchscreen remains dark, switch off the instrument, wait five seconds and switch on again. If the instrument still does not initialize, contact Miltenyi Biotec Technical Support.

9

Technical data and specifications

The MACSQuant® Instrument is labeled as a protection class I device and must be plugged into a grounded power outlet.

The MACSQuant® MiniSampler Plus is labeled as a protection class III device and must be connected to the main instrument.

Note that for USA and Canada, the main power supply cord and plug of the instrument shall comply with the following specifications: UL listed and KAM cord, minimum type SJ, minimum 18 AWG, 3 conductors. Rated for a minimum temperature of 60 °C. Provided with grounding-type (NEMA 5-15P) attachment plug, rated 125 VAC, 10 A. Opposite end terminates in IEC 320-style connector, rated 125 VAC, 10A. Supply voltage fluctuations up to +/- 10% of the nominal voltage.

This equipment has been tested and found to comply with the limits for a Class B digital device, pursuant to Part 15 of the FCC Rules. These limits are designed to provide reasonable protection against harmful interference in a residential installation. This equipment generates, uses and can radiate radio frequency energy and, if not installed and used in accordance with the instructions, may cause harmful interference to radio communications. However, there is no guarantee that interference will not occur in a particular installation. If this equipment does cause harmful interference to radio or television reception, which can be determined by turning the equipment off and on, the user is encouraged to try to correct the interference by one or more of the following measures:

- Reorient or relocate the receiving antenna,
- Increase the distance between the equipment and the receiver,
- Connect the equipment to an outlet on a circuit different from that to which the receiver is connected,
- Consult the dealer or an experienced radio/TV technician for help.

Changes or modifications of the instrument, unless expressly approved by Miltenyi Biotec, may void your authority to operate the instrument pursuant to FCC 47 CFR. For other safety considerations, refer to the product label, or visit www.miltenyibiotec.com. Design and specifications are subject to change without notice.

Technical data		Specification		
Model	MACSQuant Analyzer 10 (# 130-096-343)	MACSQuant VYB (# 130-096-116)	MACSQuant Analyzer 16 (# 130-109-803)	
Color	Green/orange			
Dimension	669 mm × 400 mm (w × d)			
Dimension with MACS MiniSampler Plus	669 mm × 500 mm (w × d)			
Footprint	385.5 mm × 284.5 mm (w × d)			
Height	392.5-520 mm (adjustable touchscreen)			
Weight	50 kg			
Input voltage	100-240 VAC, 50/60 Hz			
Power consumption	450 W			
Fuses	2 × 8 AT, 250 V			
RS232 Interface (labeled "RS232/AUX") Not in use	Pin 1, 4, 6-9: NC Pin 2: RXD Pin 3: TXD Pin 5: GND			
AC Output (labeled "Bottle Sensor")	Pin1-5: Input Pin 6-15: GND Pin 9-13: Input/Output 5 VAC/10kΩ			
RS232 Interface + DC- Output (labeled "RS232/BCR")	Pin1: Input/Output Pin 2: TXD Pin 3: RXD Pin 4,6: NC Pin 5: GND Pin 7, 8: Shorted Pin 9: 5VDC/2.6 A			
CAN Bus + DC-Output (labeled "External CAN")	Pin 1, 4, 8: NC Pin 2: CAN-L Pin 3, 6: GND Pin 5,9: 24 VDC/1.85 A Pin 7: CAN-H			
RS232 Interface (labeled "COM 1")	Pin 1: DCD Pin 2: RxD Pin 3: TxD Pin 4: DTR Pin 5: GND Pin 6: DSR Pin 7: RTS Pin 8: CTS Pin 9: RI			
CAN Bus + DC-Output (labeled "Power Can")	Pin 1: CAN-L Pin 2: CAN-H			

Technical data	Specification
	Pin 3, A2; GND Pin 4: NC Pin 5: 24 VDC/1.1 A Pin A1: 24VDC, 5A
USB ports	4x USB 2.0 ports (labeled "USB 1-4") 4x USB 3.0 ports (labeled "USB-5-8") 2x USB 3.0 ports (at Display)
DVI-D port (labeled "DVI1")	
2 × Display Port V1.2 (labeled "Display1" and "Display2")	
2 x Ethernet ports (GbE) (labeled "LAN 1" and "LAN 2")	Pin 1: TXD+ Pin 2: TXD- Pin3: RXD+ Pins 4, 5, 7, 8: NC Pin 6: RXD+
Audio ports	Green: headphones Pink: microphone
CF Card Slot	The inserted card contains the operating system of the MACSQuant Instrument (Microsoft Windows 7 with MACSQuantify Software, read-only mode)
RAM	8 GB DDR4 (SO-DIMM)
Mass storage	SSD M.2
Monitor	15,6" LCD touchscreen
Working temperature	+20 °C to +25 °C
Humidity	0% to 85% relative humidity, non-condensing
Altitude	Max. 2000 m
Emission sound pressure level at workstation	<70 dB(A)

Table 9.1: Technical specifications of the MACSQuant® Analyzer 10, VYB and Analyzer 16.

Parameter	Specification
Minimum sample volume	1 μ L (recommended)
Minimum sample particle size	1 μ m
Sample flow rate	25-100 μ l/min plus automated flow rate to maintain 500, 1000, or 2000 events/second
Sheath fluid consumption	2-10 mL/min
Maximal event rate	Up to 15,000 events/second
Lasers MACSQuant Analyzer 10	488 nm, 404 nm, 640 nm
Lasers MACSQuant VYB	561 nm, 404 nm, 488 nm
Lasers MACSQuant Analyzer 16	404 nm, 488 nm, 642 nm
Fluorescence sensitivity	MESFs (CV <5%); FITC < 200; PE < 100; APC < 150
Absolute cell count performance	Accuracy +/- 7%; reproducibility (CV) <5%
Sample carryover	Typical value of 0.01%

Table 9.2: Operation details of the MACSQuant Analyzer 10, VYB and Analyzer 16.

Model	Channel	Laser [nm]	Filter
MACSQuant Analyzer 10	FSC	488	488/10
	SSC	488	488/10
	V1	405	450/50
	V2	405	525/50
	B1	488	525/50
	B2	488	585/40
	B3	488	655-730
	B4	488	750LP
	R1	635	655-730
R2	635	750LP	
MACSQuant VYB	FSC	561	561/4
	SSC	561	561/4
	V1	405	425/45
	V2	405	525/50
	B1	488	525/50
	B2	488	593-650
	Y1	561	586/15
	Y2	561	615/20
	Y3	561	661/20
	Y4	561	740LP
MACSQuant Analyzer 16	FSC	488	488/10
	SSC	405	405/10
	V1	405	450/50
	V2	405	525/50
	V3	405	579/34
	V4	405	615/20
	V5	405	667/30
	B1	488	525/50
	B2	488	579/34
	B3	488	615/20
	B4	488	667/30
	B5	488	725/40
	B6	488	785/62
	R1	638	667/30
	R2	638	725/40
R3	638	785/62	

Table 9.3: Instrument configurations.

9.1 EC / EU Declaration of Conformity

This declaration of conformity is issued under the sole responsibility of the manufacturer:

Miltenyi Biotec B.V. & Co. KG
 Friedrich-Ebert-Straße 68
 51429 Bergisch Gladbach
 Germany

This declaration relates exclusively to the machinery in the state in which it was placed on the market, and excludes components which are added and/or operations carried out subsequently by the final user.

The declaration of conformity refers to the machinery identified as follows:

Description: Laboratory equipment

Model: MACSQuant® Analyzer 10

The machinery complies with all essential requirements of the following directives:

2006/42/EC Machinery

2011/65/EU Restriction of the use of certain hazardous substances in electrical & electronic equipment

2014/30/EU Electromagnetic compatibility

The machinery is in conformity with the following harmonized standards:

EN 60825-1:2014

EN 61010-1:2010

EN 61010-2-081:2015

EN 61326-1:2013

Person authorized to compile the relevant technical documentation:

Stefan Miltenyi

Miltenyi Biotec B.V. & Co. KG

Friedrich-Ebert-Straße 68

51429 Bergisch Gladbach

Germany

Additional international conformity (MACSQuant Analyzer 10)

The MACSQuant® Analyzer 10 is in conformity with:

- IEC 61010-1
- IEC 61010-2-081
- UL 61010-1
- UL 61010-2-081
- CAN/CSA-C22.2 No. 61010-1
- CAN/CSA-C22.2 No. 61010-2-081
- IEC 60825-1
- CAN/CSA-E60825-1

9.2 EC / EU Declaration of Conformity

This declaration of conformity is issued under the sole responsibility of the manufacturer:

Miltenyi Biotec B.V. & Co. KG

Friedrich-Ebert-Straße 68

51429 Bergisch Gladbach

Germany

This declaration relates exclusively to the machinery in the state in which it was placed on the market, and excludes components which are added and/or operations carried out subsequently by the final user.

The declaration of conformity refers to the machinery identified as follows:

Description: Laboratory equipment

Model: MACSQuant® VYB

The machinery complies with all essential requirements of the following directives:

2006/42/EC Machinery

2011/65/EU Restriction of the use of certain hazardous substances in electrical & electronic equipment

2014/30/EU Electromagnetic compatibility

The machinery is in conformity with the following harmonized standards:

EN 60825-1:2014

EN 61010-1:2010

EN 61010-2-081:2015

EN 61326-1:2013

Person authorized to compile the relevant technical documentation:

Stefan Miltenyi

Miltenyi Biotec B.V. & Co. KG

Friedrich-Ebert-Straße 68

51429 Bergisch Gladbach

Germany

Additional international conformity (MACSQuant VYB)

The MACSQuant® VYB is in conformity with:

- IEC 61010-1
- IEC 61010-2-081
- UL 61010-1
- UL 61010-2-081
- CAN/CSA-C22.2 No. 61010-1
- CAN/CSA-C22.2 No. 61010-2-081
- IEC 60825-1
- CAN/CSA-E60825-1

9.3 EC / EU Declaration of Conformity

This declaration of conformity is issued under the sole responsibility of the manufacturer:

Miltenyi Biotec B.V. & Co. KG

Friedrich-Ebert-Straße 68

51429 Bergisch Gladbach

Germany

This declaration relates exclusively to the machinery in the state in which it was placed on the market, and excludes components which are added and/or operations carried out subsequently by the final user.

The declaration of conformity refers to the machinery identified as follows:

Description: Laboratory equipment

Model: MACSQuant® Analyzer 16

The machinery complies with all essential requirements of the following directives:

2006/42/EC Machinery

2011/65/EU Restriction of the use of certain hazardous substances in electrical & electronic equipment

2014/30/EU Electromagnetic compatibility

The machinery is in conformity with the following harmonized standards:

EN 60825-1:2014

EN 61010-1:2010

EN 61010-2-081:2015

EN 61326-1:2013

Person authorized to compile the relevant technical documentation:

Stefan Miltenyi

Miltenyi Biotec B.V. & Co. KG

Friedrich-Ebert-Straße 68

51429 Bergisch Gladbach

Germany

Additional international conformity (MACSQuant Analyzer 16)

The MACSQuant® Analyzer 16 is in conformity with:

- IEC 61010-1
- IEC 61010-2-081
- UL 61010-1
- UL 61010-2-081
- CAN/CSA-C22.2 No. 61010-1
- CAN/CSA-C22.2 No. 61010-2-081
- IEC 60825-1
- CAN/CSA-E60825-1

9.4 Technical data and specifications of the MACS MiniSampler Plus

The MACS® MiniSampler Plus is labeled as a protection class III device and must be plugged into the connector of the Instrument labeled with **External CAN**.

For other safety considerations, refer to the product label, or visit www.miltenyibiotec.com.

Design and specifications are subject to change without notice.

Parameter	Specification
Size without lid	182 mm x 148 mm x 47 mm
Size with lid	280 mm x 153 mm x 172 mm
Weight	1.5 kg
Input voltage	24 VDC
Current	0.8 A
Sub D9 interface with shielding	Pins 1,4 and 8: NC Pin 2: CAN-L Pin 3 and 6: GND Pin 5 and 9: +24 VDC/2A Pin 7: CAN-H
Working temperature	+ 20 °C to + 25 °C
Humidity	0% to 85% relative humidity, non-condensing
Altitude	max. 2000 m

Table 9.4: Technical specifications of the MACS MiniSampler Plus.

9.5 EC / EU Declaration of Conformity

This declaration of conformity is issued under the sole responsibility of the manufacturer:

Miltenyi Biotec B.V. & Co. KG
Friedrich-Ebert-Straße 68
51429 Bergisch Gladbach
Germany

This declaration relates exclusively to the machinery in the state in which it was placed on the market, and excludes components which are added and/or operations carried out subsequently by the final user.

The declaration of conformity refers to the machinery identified as follows:

Description: Laboratory equipment

Model: MACS® MiniSampler Plus

The machinery complies with all essential requirements of the following directives:

2006/42/EC Machinery

2011/65/EU Restriction of the use of certain hazardous substances in electrical & electronic equipment

2014/30/EU Electromagnetic compatibility

The machinery is in conformity with the following harmonized standards:

EN 61010-1:2010

EN 61010-2-081:2015

EN 61326-1:2013

Person authorized to compile the relevant technical documentation:

Stefan Miltenyi

Miltenyi Biotec B.V. & Co. KG

Friedrich-Ebert-Straße 68

51429 Bergisch Gladbach

Germany

10

Technical support

For technical support, contact your local Miltenyi Biotec representative or Miltenyi Biotec Technical Support at Miltenyi Biotec headquarters:

Miltenyi Biotec B.V. & Co. KG
Friedrich-Ebert-Straße 68
51429 Bergisch Gladbach
Germany
Phone: +49 2204 8306 3803
Fax +49 2204 8306-89
Email: technicalsupport@miltenyi.com

Visit www.miltenyibiotec.com/local to find your nearest Miltenyi Biotec contact.

11

Limited warranty

Except as stated in a specific warranty statement which may accompany this product or as otherwise agreed in writing by an authorized representative of Miltenyi Biotec, Miltenyi Biotec's warranty to you, the original purchaser and end user ("you" or "your"), with respect to the product accompanied by this limited warranty shall be subject to the following provisions and the general terms and conditions of sale of the company within the Miltenyi Biotec group which supplied the product in effect at the date of purchase. Those terms and conditions of sale may vary by country and region. Nothing in this document should be construed as constituting an additional warranty.

Miltenyi Biotec warrants that this product will operate or perform substantially in conformance with Miltenyi Biotec's published specifications and be free from material defects in material and workmanship, when subjected to normal, proper, and intended usage by properly trained personnel, for the period of time set forth in the product documentation or package inserts accompanying the product (the "Warranty Period").

Miltenyi Biotec agrees, during the Warranty Period, to repair or replace, at Miltenyi Biotec's option, the defective product so as to cause the same to operate in substantial conformance with said published specifications; provided that you shall (a) promptly notify Miltenyi Biotec in writing upon the discovery of any nonconformity or defect, which notice shall include the product model and serial number (if applicable) and details of the warranty claim; and (b) return the nonconforming or defective product to Miltenyi Biotec, freight prepaid, only after receipt of a Return Material Authorization ("RMA") from Miltenyi Biotec, which may include biohazard decontamination procedures and other product-specific handling instructions, if applicable.

Miltenyi Biotec shall have no obligation to make repairs, replacements, or corrections to the product or any component thereof required, in whole or in part, as the result of (i) normal wear and tear, (ii) improper handling, installation, operation, storage, service, maintenance, or repair, (iii) failure to follow the instructions, cautions, warnings, and notes set forth in the product documentation provided with the product or provided by Miltenyi Biotec from time to time, (iv) abnormal use, misuse, neglect, abuse, mishandling, misapplication, modification, or alteration of the product, (v) use of the product in a manner for which it was not designed, (vi) causes external to the product such as, but not limited to, power failure or electrical power surges, (vii) use of the product in combination with equipment, accessories, consumables, or software not supplied or approved by Miltenyi Biotec, or (viii) accident, disaster, or acts of God. ANY INSTALLATION, MAINTENANCE, REPAIR, SERVICE, OR ALTERATION TO OR OF, OR OTHER TAMPERING WITH, THE PRODUCT PERFORMED BY ANY PERSON OR ENTITY OTHER THAN MILTENYI BIOTEC AUTHORIZED PERSONNEL WITHOUT MILTENYI BIOTEC'S PRIOR WRITTEN APPROVAL, OR ANY USE OF REPLACEMENT PARTS NOT SUPPLIED BY MILTENYI BIOTEC, SHALL IMMEDIATELY VOID AND CANCEL ALL WARRANTIES WITH RESPECT TO THE AFFECTED PRODUCT.

Miltenyi Biotec's warranty does not cover products sold AS IS or WITH ALL FAULTS, or which had its serial number defaced, altered, or removed, or any consumables or parts identified as being supplied by a third party.

Miltenyi Biotec must be informed promptly if a claim is made under this limited warranty. If a material or manufacturing defect occurs within the Warranty Period, Miltenyi Biotec will take the appropriate steps, at Miltenyi Biotec's option, to make repairs, replacements, or corrections to the product or any component thereof as may be required to restore the full usability of your product. If Miltenyi Biotec determines that a product for which you have requested warranty services is not covered by the warranty hereunder, you shall pay or reimburse Miltenyi Biotec for all costs of investigating and responding to such request at Miltenyi Biotec's then prevailing time and materials rates. If Miltenyi Biotec provides repair services or replacement parts that are not covered by this warranty, you shall pay Miltenyi Biotec therefor at Miltenyi Biotec's then prevailing time and materials rates.

THE OBLIGATIONS CREATED BY THIS WARRANTY STATEMENT TO REPAIR OR REPLACE A DEFECTIVE PRODUCT ARE EXCLUSIVE AND SHALL BE THE SOLE REMEDY OF BUYER IN THE EVENT OF A DEFECTIVE PRODUCT. EXCEPT AS EXPRESSLY PROVIDED IN THIS WARRANTY STATEMENT, MILTENYI BIOTEC HEREBY DISCLAIMS ALL OTHER WARRANTIES, WHETHER EXPRESS OR IMPLIED, ORAL OR WRITTEN, WITH RESPECT TO THE PRODUCT, INCLUDING WITHOUT LIMITATION ALL IMPLIED WARRANTIES OF MERCHANTABILITY OR FITNESS FOR ANY PARTICULAR PURPOSE. MILTENYI BIOTEC DOES NOT WARRANT THAT THE PRODUCT IS ERROR-FREE OR WILL ACCOMPLISH ANY PARTICULAR RESULT.

UNDER NO CIRCUMSTANCES WILL MILTENYI BIOTEC BE LIABLE FOR ANY LOSS OF USE, INTERRUPTION OF BUSINESS, OR ANY INDIRECT, SPECIAL, INCIDENTAL, PUNITIVE, OR CONSEQUENTIAL DAMAGES OF ANY KIND (INCLUDING LOST PROFITS) REGARDLESS OF THE FORM OF ACTION WHETHER IN CONTRACT, TORT (INCLUDING NEGLIGENCE), STRICT PRODUCT LIABILITY, OR OTHERWISE, EVEN IF MILTENYI BIOTEC HAS BEEN ADVISED OF THE POSSIBILITY OF SUCH DAMAGES. IN NO EVENT SHALL THE TOTAL LIABILITY OF MILTENYI BIOTEC HEREUNDER EXCEED THE GREATER OF 100.00 EUROS OR THE AMOUNT YOU ACTUALLY PAID FOR THE PRODUCT GIVING RISE TO SUCH LIABILITY, REGARDLESS OF THE CAUSE OF ACTION, IN CONTRACT, TORT, STRICT LIABILITY, OR OTHERWISE.

NOT ALL JURISDICTIONS ALLOW SUCH LIMITATIONS OF DAMAGES SO THE FOREGOING LIMITATIONS MAY NOT APPLY TO YOU. This warranty statement gives you specific legal rights and you may have other rights, which may vary from jurisdiction to jurisdiction.

Index

C

Calibration **77**

Chill 5 Rack **79**

Chill 96 Rack **79**

Chill Rack detection **82**

MACSPlex **80**

Reagent Rack 4 **80**

Robotic Needle Arm **77**

Single Tube Rack **79**

Single Tube Rack detection **81**

Universal Reagent Rack **81**

Column leakage **93**

Complementary components **62**

Connect the instrument **65**

Consumables **62**

E

Excessive debris **93**

Exchange fluid bottles **91**

Exchange MACSQuant Columns **91**

I

Installation

Fluid bottles **63**

MACSQuant Column **66**

MiniSampler Plus **69**

needle guard **68**

Single tube rack **65**

Webcam **67**

Instrument monitoring

Lasers and detectors **86**

LED colors **87**

Sample uptake unit **86**

K

Key features **57**

L

Live support **89**

Long-term storage **76**

M

MACSQuant 10 **57**

MACSQuant 16 **57**

MACSQuant VYB **57**

Maintenance

Decontamination **91**

Exchange fluid bottles **91**

Exchange MACSQuant Columns **91**

S

Service contracts **62**

Shutdown

automatic **75**

manual **75**

Syringe pump leakage **93**

T

Troubleshootin

Air bubbles **93**

Troubleshooting

Column leakage **93**

Excessive debris **93**

Syringe pump leakage **93**

Touchscreen remains dark **94**



Miltenyi Biotec

Germany/Austria

Miltenyi Biotec B.V. & Co. KG
Friedrich-Ebert-Straße 68
51429 Bergisch Gladbach
Germany
Phone +49 2204 8306-0
Fax +49 2204 85197
macsde@miltenyi.com

USA/Canada

Miltenyi Biotec Inc.
2303 Lindbergh Street
Auburn, CA 95602, USA
Phone 800 FOR MACS
Phone +1 530 888 8871
Fax +1 877 591 1060
macsus@miltenyi.com

Australia

Miltenyi Biotec
Australia Pty. Ltd.
Unit 11, 2 Eden Park Drive
Macquarie Park NSW 2113
Australia
Phone +61 2 8877 7400
Fax +61 2 9889 5044
macsau@miltenyi.com

Benelux

Miltenyi Biotec B.V.
Sandfortdreef 17
2333 ZZ Leiden
The Netherlands
macsnl@miltenyi.com

Customer service

The Netherlands
Phone 0800 4020120
Fax 0800 4020100

Customer service Belgium

Phone 0800 94016
Fax 0800 99626

Customer service Luxembourg

Phone 800 24971
Fax 800 24984

China

Miltenyi Biotec Technology &
Trading (Shanghai) Co., Ltd.
Room 407
No. 1077, Zhangheng Road
Pudong New Area
201203 Shanghai, P.R. China
Phone +86 21 62351005
Fax +86 21 62350953
macscn@miltenyi.com

France

Miltenyi Biotec SAS
10 rue Mercoeur
75011 Paris, France
Phone +33 1 56 98 16 16
Fax +33 1 56 98 16 17
macsfr@miltenyi.com

Italy

Miltenyi Biotec S.r.l.
Via Paolo Nanni Costa, 30
40133 Bologna
Italy
Phone +39 051 6 460 411
Fax +39 051 6 460 499
macsit@miltenyi.com

Japan

Miltenyi Biotec K.K.
NEX-Eitai Building 5F
16-10 Fuyuki, Koto-ku,
Tokyo 135-0041, Japan
Phone +81 3 5646 8910
Fax +81 3 5646 8911
macsjp@miltenyi.com

Nordics and Baltics

Miltenyi Biotec Norden AB
Medicon Village
Scheeleorget 1
223 81 Lund
Sweden
macsse@miltenyi.com

Customer service Sweden

Phone 0200 111 800

Customer service Denmark

Phone 80 20 30 10

Customer service

**Norway, Finland, Iceland
and Baltic countries**
Phone +46 46 280 72 80

Singapore

Miltenyi Biotec Asia Pacific Pte Ltd
438B Alexandra Road, Block B
Alexandra Technopark
#06-01
Singapore 119968
Phone +65 6238 8183
Fax +65 6238 0302
macssg@miltenyi.com

South Korea

Miltenyi Biotec Korea Co., Ltd.
Arigi Bldg. 8F
562 Nonhyeon-ro
Gangnam-gu
Seoul 06136, South Korea
Phone +82 2 555 1988
Fax +82 2 555 8890
macskr@miltenyi.com

Spain

Miltenyi Biotec S.L.
C/Luis Buñuel 2
Ciudad de la Imagen
28223 Pozuelo de Alarcón
(Madrid)
Spain
Phone +34 91 512 12 90
Fax +34 91 512 12 91
macses@miltenyi.com

Switzerland

Miltenyi Biotec Swiss AG
Gibelinstrasse 27
4500 Solothurn
Switzerland
Phone +41 32 623 08 47
Fax +49 2204 85197
macsch@miltenyi.com

United Kingdom

Miltenyi Biotec Ltd.
Almac House, Church Lane
Bisley, Surrey GU24 9DR, UK
Phone +44 1483 799 800
Fax +44 1483 799 811
macsuk@miltenyi.com

www.miltenyibiotec.com

Miltenyi Biotec provides products and services worldwide. Visit www.miltenyibiotec.com/local to find your nearest Miltenyi Biotec contact.

Unless otherwise specifically indicated, Miltenyi Biotec products and services are for research use only and not for therapeutic or diagnostic use. MACS, MACSima, MACSQuant, MACSQuantify and the Miltenyi Biotec Logo are registered trademarks or trademarks of Miltenyi Biotec and/or its affiliates in various countries worldwide. All other trademarks mentioned in this publication are the property of their respective owners and are used for identification purposes only.
Copyright © 2020 Miltenyi Biotec and/or its affiliates. All rights reserved.