

Case studies optimization 2026

Jan Friedrich, Felix Heinermann and Andreas Wiese

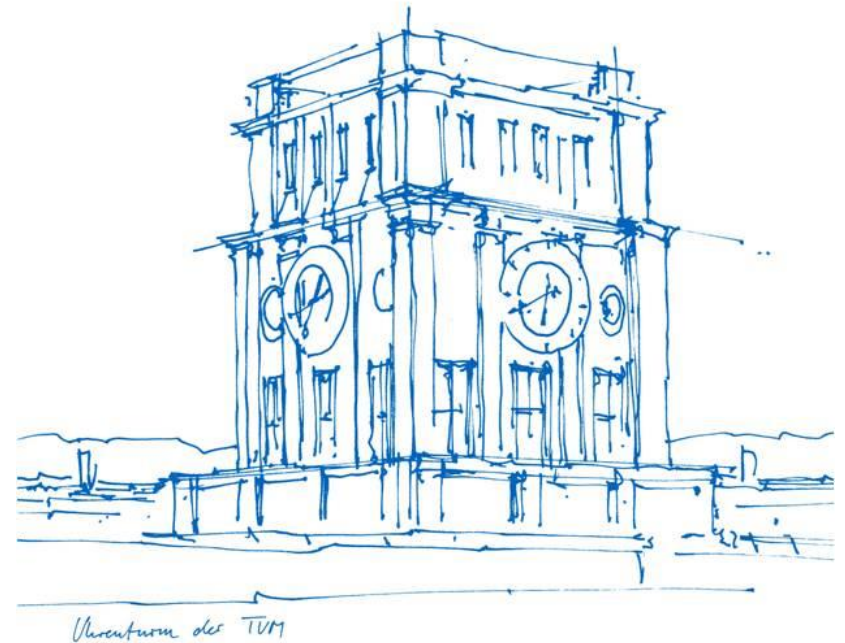

Welcome

Who are we?



Jan Friedrich



Felix Heinermann



Andreas Wiese

Who are you?

<https://tweedback.de/2r6v>



What will you learn?



- Apply mathematical skills to practical optimization problems
- analyze and model problems
- implement suitable algorithms

What will you learn?



- work with practitioners
- real-world challenges
- Communicate to different audiences
- Outreach / science communication
- Experience the impact of your work

What will you learn?

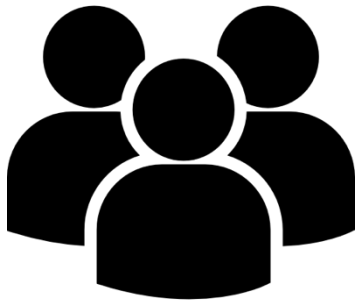

- Experience teamwork / team dynamics
- self/team management
- Organization / documentation / communication

Projects

Supply-Chain Optimization with Embargo Constraints

SAP

How can modern supply-chains stay resilient?

ECONOMY

Here's the Latest Trump Tariffs on Countries and Products

See which countries and industries are being targeted by President Trump, as he seeks to remake the global trading system.

By Tony Romm, Lazaro Gamio and Agnes Chang



BUSINESS

China's Critical Minerals Embargo Is Even Tougher Than Expected

Beijing ordered companies around the world not to allow critical minerals mined in China to reach the U.S., while deepening its efforts to replace imports with domestic products.

By Keith Bradsher



POLITICS

Trump Administration Delays Tariffs on Chinese Semiconductors

An investigation ruled that China's inroads into the chip industry had hurt the United States. The administration delayed tariffs until 2027 amid a fragile truce between the countries.

By Ana Swanson



PRINT EDITION U.S. Delays Tariffs On Semiconductors From Chinese Firms | December 24, 2025, Page B3

Supply-Chain Optimization with Embargo Constraints

Task: Optimize the global supply-chain of a high-tech company producing smartphones while fulfilling given embargo constraints.

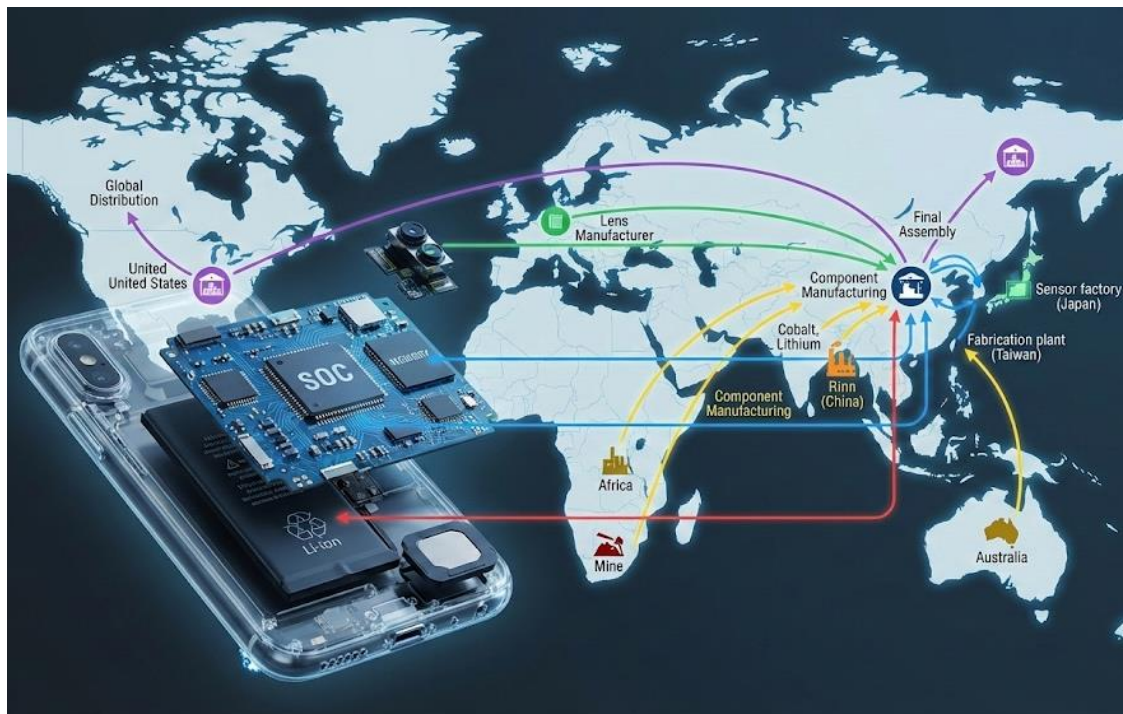

Example of Embargo Constraints:

- Smartphones for the U.S. market are prohibited from including SoCs (System on a Chip) from Chinese companies
- devices produced for the European Union may only use batteries from certified Japanese or South Korean suppliers

Who you'll be working with



Dr. Jakob Witzig
SCM Quantum, Optimization & AI
SAP



Dr. Marilena Leichter
SCM Quantum, Optimization & AI
SAP

Energy Flexibility in Production Scheduling

Siemens AG

Energy Flexibility in Production Scheduling

Motivation: Many renewables in the grid require energy flexibility

Problem: Find flexibility offers, i.e., ...

- load adjustments during certain time windows,
- taking operational constraints into account,
- including an offer for flexibility premiums,
- to minimize total energy costs
- ... and more

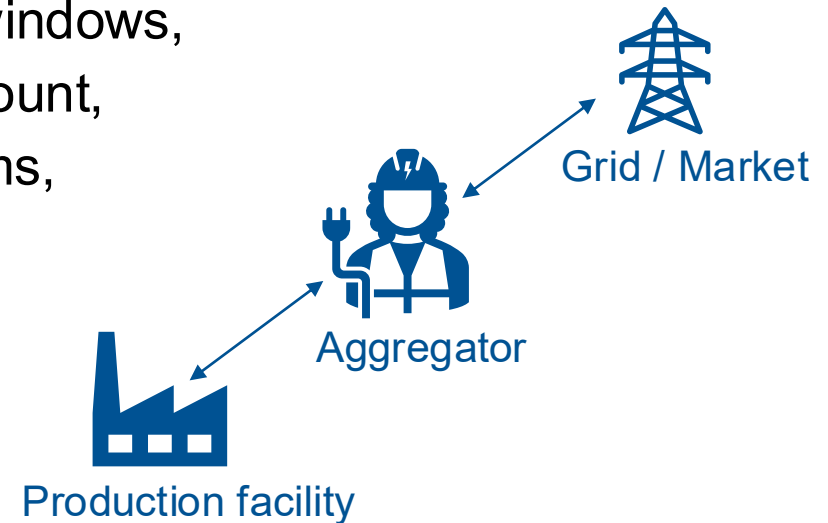

Energy Flexibility in Production Scheduling

Your Task:

- Set up a suitable model (e.g., mixed integer linear program)
 - Scheduling with time-dependent energy prices
 - Negotiable flexibility premiums
- Develop and implement suitable solution methods
- Analyze results on benchmark problems

Possible Extensions:

- Multi-criteria optimization: energy cost vs. production efficiency
- Auction model for the negotiation process between aggregator and consumer

Car rental optimization

SIXT SE

SIXT SE

Global Premium Mobility Service Provider

Financial Performance (FY 2024)

€4.00bn

Revenue (+10.5%)

€335.2M

EBT

184,300

Avg. Fleet Size (+8.9%)

~10%

2025 EBT Margin Target

Global Footprint

- **110+ countries** worldwide presence
- Focus: **Germany, Europe, North America**
- Leading market positions (e.g., ~19% share MIA, ~15% JFK)
- Premium fleet strategy with high customer satisfaction
- Franchise & cooperation partners globally

Business Model & Strategy

- **Multi-product platform:** Car rental (core), car sharing (SIXT share), car subscription (SIXT+), ride-hailing (SIXT ride)
- **Premium positioning:** BMW, Audi, Mercedes-Benz focus
- **Technology-driven:** Best-in-class app integration
- **Growth trajectory:** 4th consecutive record year, continued expansion

2025 Outlook & Key Facts

- **2025 Revenue target:** ~€4.25bn (+6%)
- **Founded:** 1912 (family-controlled)
- **Listed:** Frankfurt Stock Exchange since 1986
- **Resilience:** 10-year consecutive growth (except COVID-19)
- Strong Q3 2025: Record revenue, +23% profit YoY

The Vehicle Assignment Challenge

- Decision support system: optimally allocate vehicles!
 - upgrade paths/upselling
 - no-shows/cancellations
 - overbookings
 - car transfers
 - competing priorities
- Creative exploration: rule-based optimization, ML approaches, etc.
- Real operational problem, thousands of daily transactions across SIXT's branches
 - Sixt experts from several divisions are excited discuss problem with you!

Graph-based Optimal transport for Keypoint Matching

Chair of Computer Aided Medical
Procedures

Application: Pose estimation

- **Predict rotation** of an object from a single view, e.g. in robotics
- **Approach:** Keypoints are extracted from 2D images (via Graph-based Neural Networks) and matched to the 3D template (via optimal transport)

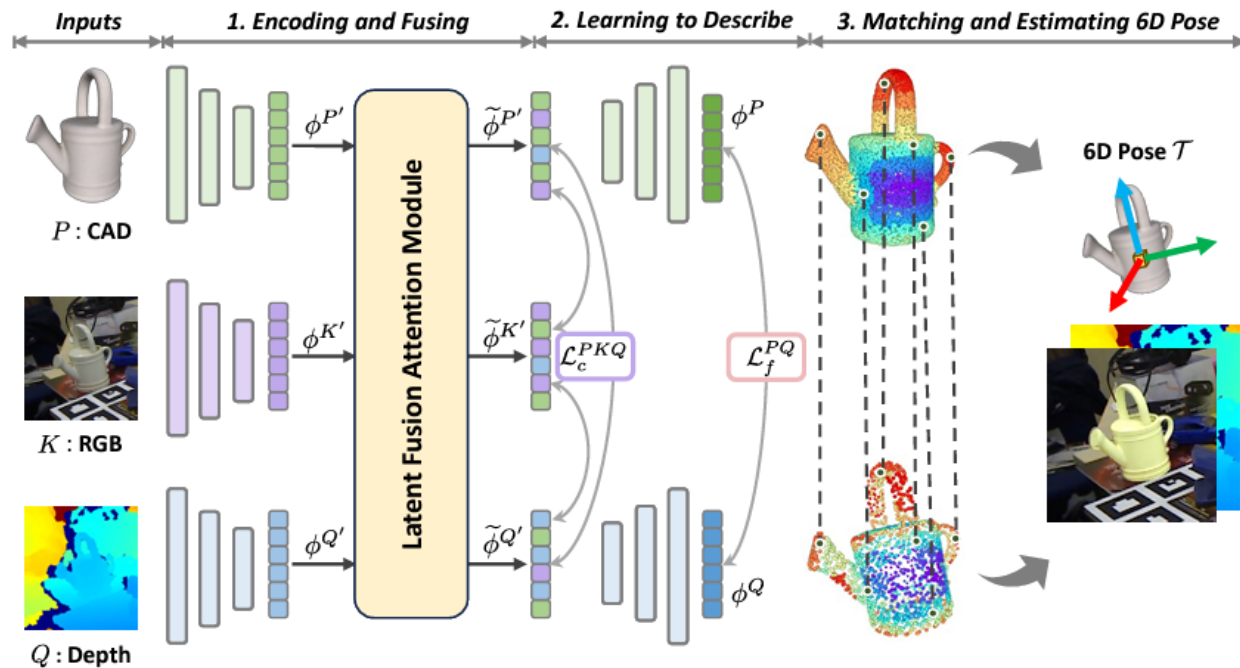

Symmetric objects: good or bad?

- A lot of real objects are **symmetric**:
 - there are **many correct matches**
- Current OT solvers provide **one** solution
- This introduces **huge noise** to pose calculation

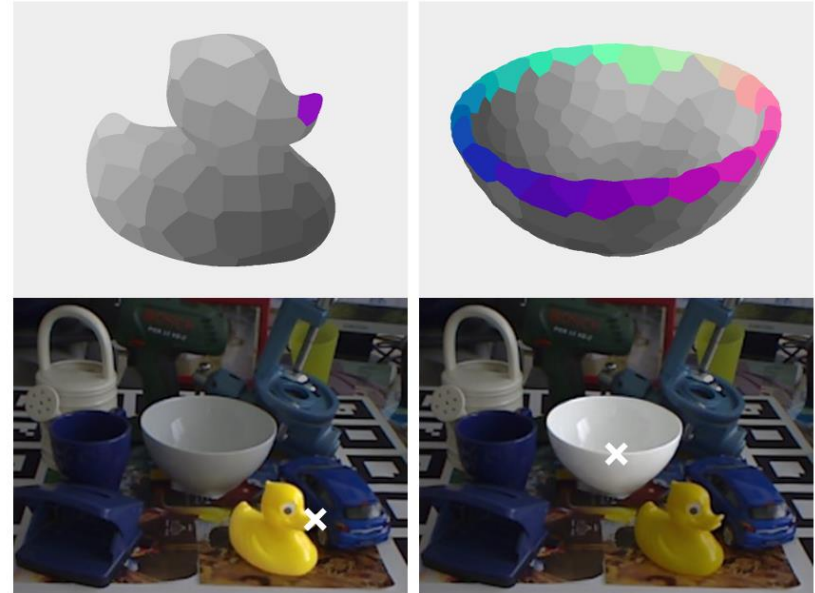

Challenges:

- We are interested in „one-to-many solutions“:
 - Extension of Optimal Transport needed!
- Can we identify the axis of symmetry?
- Can we reduce the noise?

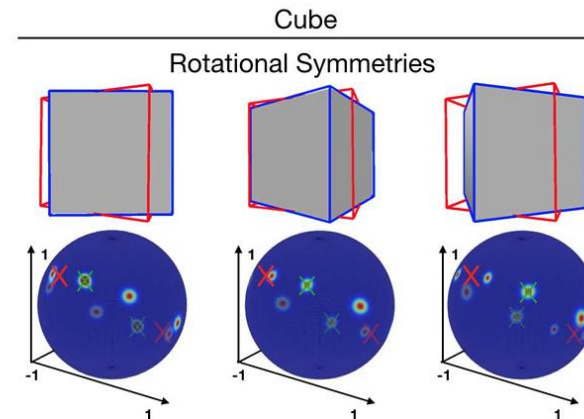
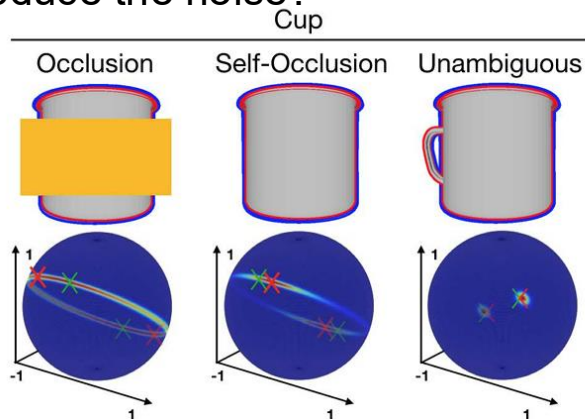

Synthesis of Model Predictive Control and Reinforcement Learning for Vehicle Control

Siemens AG

Vehicle / Robot Control

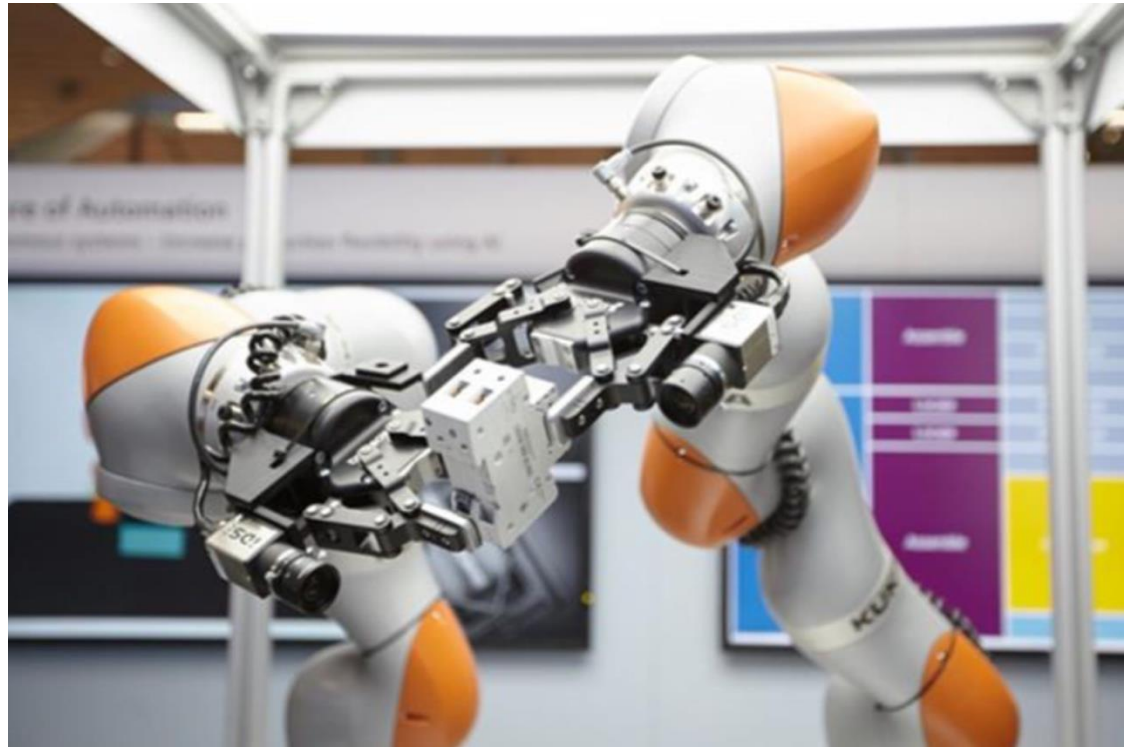

Accurate models of dynamics and environment are difficult to obtain!

Model Predictive Control (MPC)

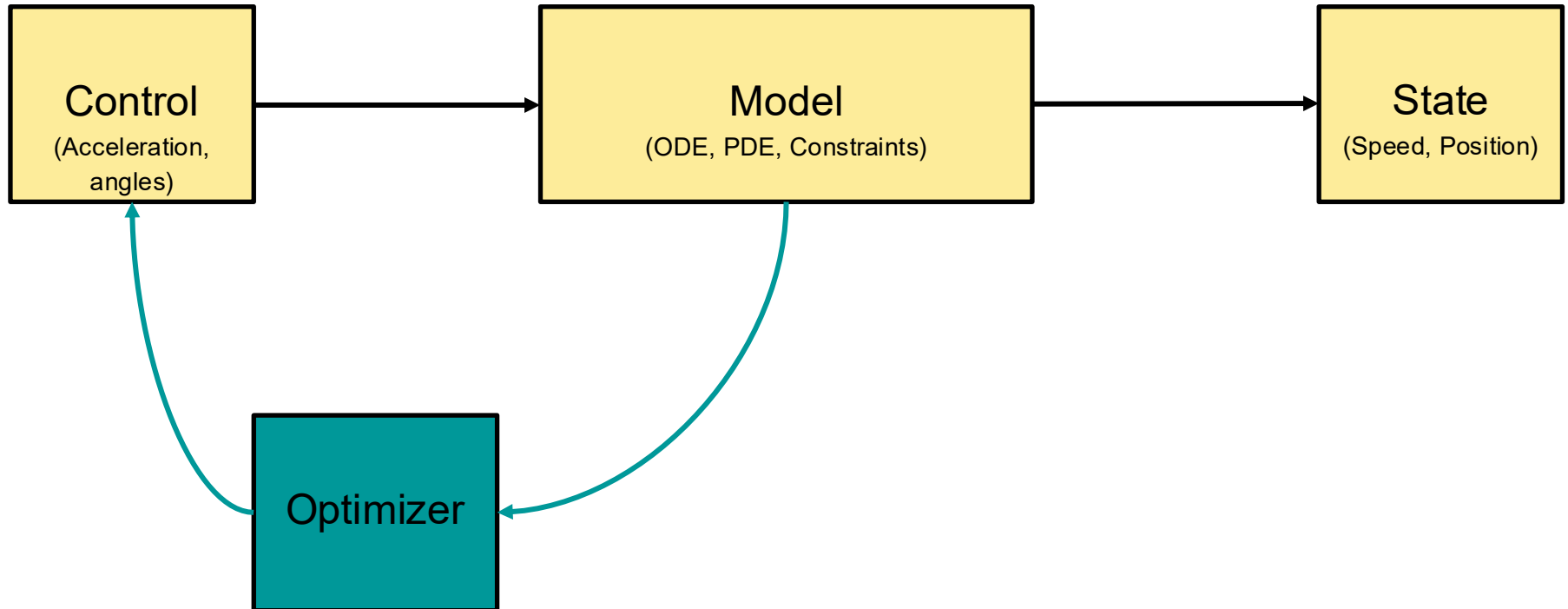

MPC determines optimal control inputs based on given dynamic model.

Reinforcement learning (RL)

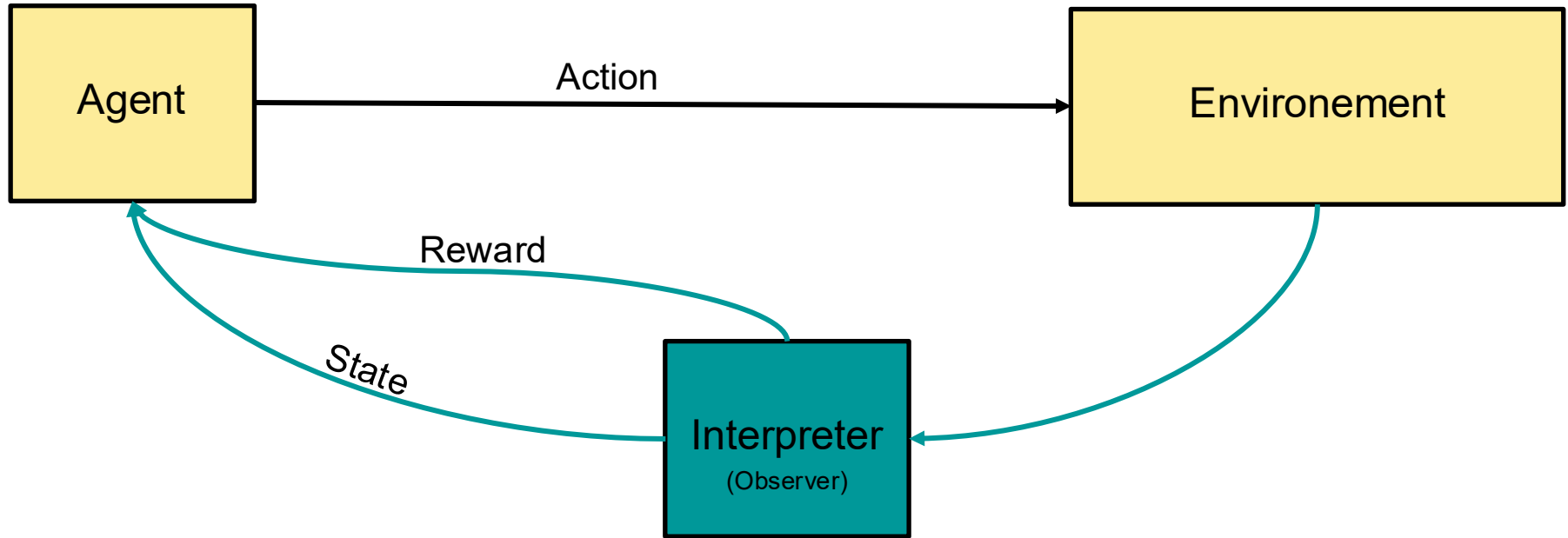

RL determines controls by trial and error given real-world feedback



Combine MPC and RL to obtain reliable and adaptive control policy

Investigate and implement a respective framework

- Accommodate yourself with MPC and RL
- Test performance of nominal MPC and RL approaches for given problem setting
- Adapt open-source code to obtain combined approach
- Use Python libraries PyTorch and CasADi

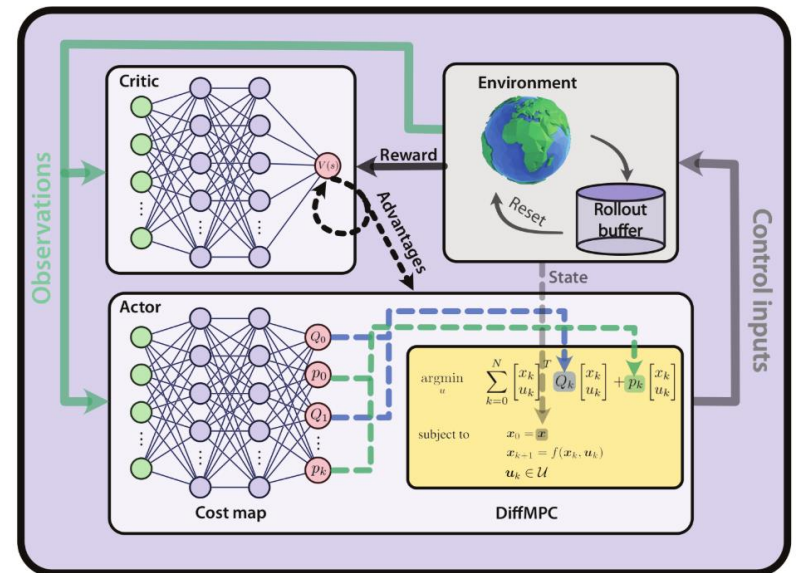

From: "Actor-Critic Model Predictive Control: Differentiable Optimization Meets Reinforcement Learning for Agile Flight". *Angel Romero, Elie Aljalbout, Yunlong Song, Davide Scaramuzza*. arXiv preprint arXiv:2306.09852.

Data-Driven Optimization for Turbulence Modeling

Hawe Hydraulic

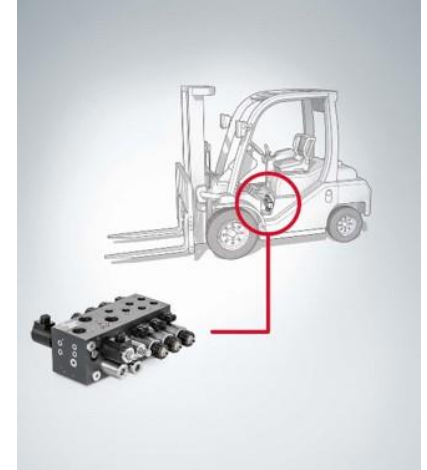
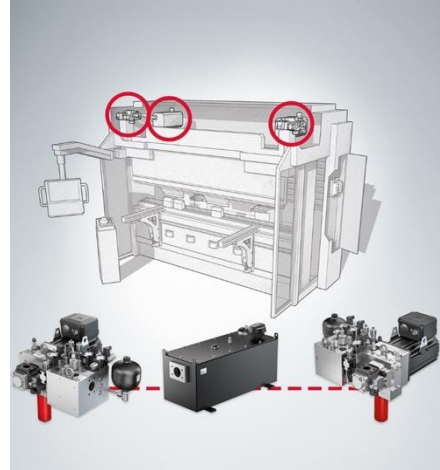
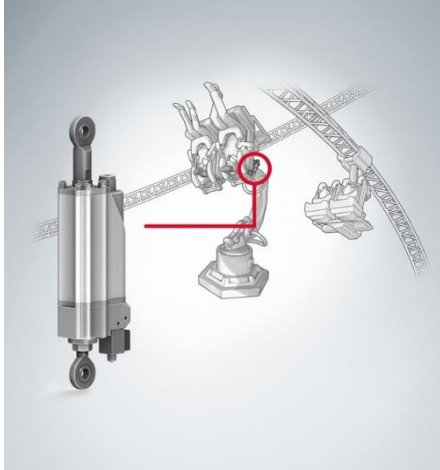

Data-Driven Optimization for Turbulence Modeling

- **Key challenge** in computational fluid dynamics: **trade-off** between simulation **accuracy** and computational **efficiency**
- **Solution**: data-driven optimal calibration of turbulence model parameters
- **Nonlinear, gradient-free optimization** for industrial CFD simulations and real-world benchmark flows
- **Hands-on work** with RANS solvers (e.g. ANSYS Fluent, OpenFOAM)

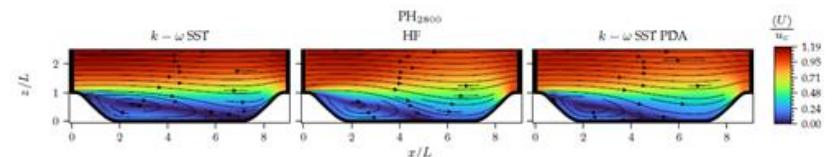
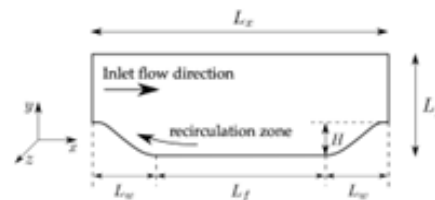
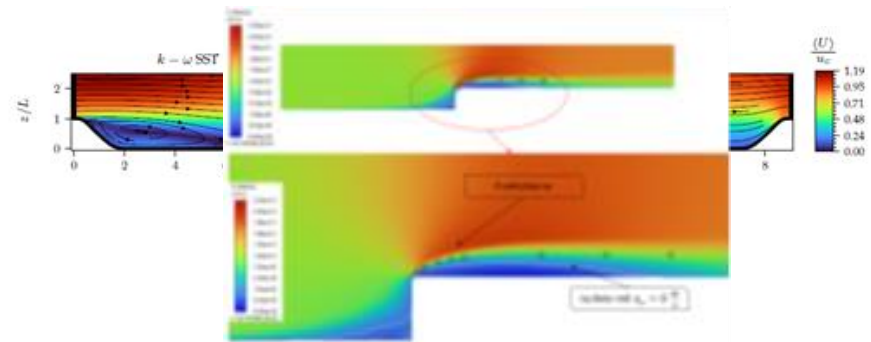
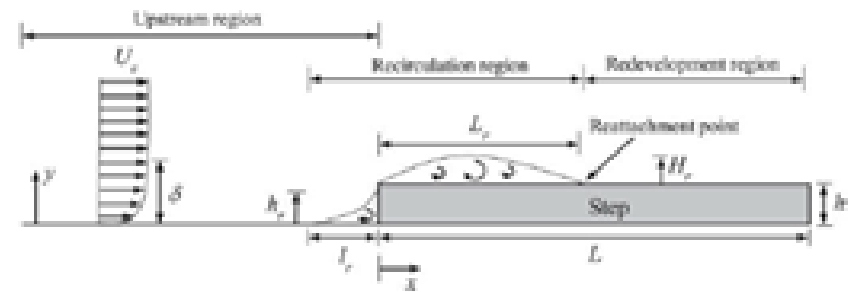

(a) Velocity magnitude contours.

• High Fidelity — $k-\omega$ SST - - $k-\omega$ SST PDA

All projects

Discrete Optimization

- Supply-chain Optimization with Embargo Constraints
- Energy Flexibility in Production Scheduling
- Vehicle Allocation Optimization

Nonlinear Optimization

- Graph-based Optimal Transport for Keypoint Matching
- Synthesis of Model Predictive Control and Reinforcement Learning for Vehicle Control
- Data-Driven Optimization for Turbulence Modeling

We expect...



- dedication
- be open for challenges
- Creativity
- Motivation for real-world challenges
- Teamwork & communication

Successful Participation



- In-person participation only
- Active project work and contributions to project outcome
- Mandatory participation in central meetings
- Active contributions to presentations and final report

Workload



- 10 ECTS
- 300 hours total semester workload per person
- Estimated workload: 20 hours per week
- Groups of ~ 4 students

Grading

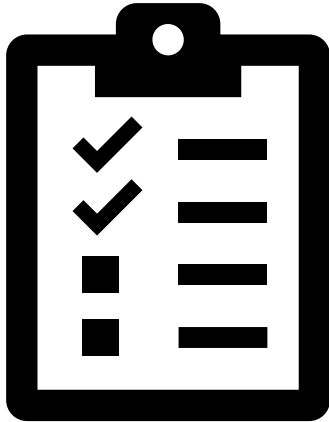

- Project work
- Project report
- Poster
- Presentation

Required courses/knowledge in Optimization

- Einführung in die Optimierung
- Nonlinear Optimization
 - Numerical Analysis
 - Nonlinear Optimization: Advanced
 - Modern Methods of Nonlinear Optimization (optional)
- Discrete Optimization
 - Discrete/Integer Optimization
 - Combinatorial Optimization (optional)

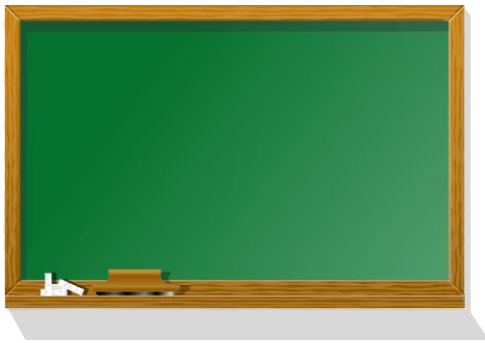

Application

- Limited intake
- **Application deadline:** 15 March 2026
- Online application form → **website**
- Courses, skills, project ranking, preferred team members, etc.
- Final allocation: until beginning of April
- Important dates → **website**



Preliminary schedule

- **Kickoff:** Wed, April 15, 4pm
- **Poster workshop:** TBA
- **Poster presentation:** Fri, May 29, 12:00-15:00
- **Final workshop:** Mo/Tue, July 13/14, (afternoon/evening)
- **Further events** (presentation skills, midterm presentation, ...) will be scheduled on Mondays

Why participate?



- apply mathematical theory to real-world challenges
- project management and team organization
- Communication and presentation skills

Case studies optimization 2026



solve optimization problems



real-world challenges



teamwork

apply until March 15