

# Chrono Corp

Milestone 4. Alpha Release

Anian Kalb, Árpád Horváth, Lukas Jonsson

# Our Game

- Network Management
- Energy distribution
- Time Slices

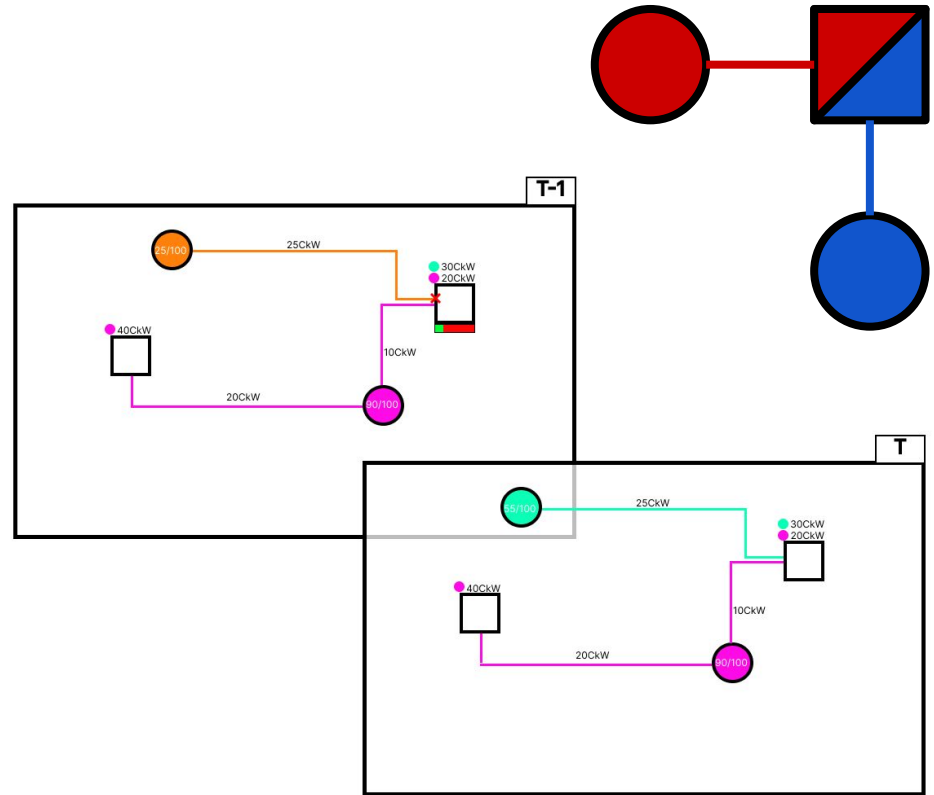

# Progress compared to plan

Done:

- Multiple playable layers
- Automatic timeripple spawning across multiple layers
- Player inventory
- 3d visuals

Missing:

- Win/loose condition
- Audio

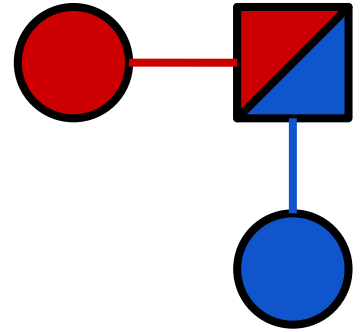

# 3D Visualization

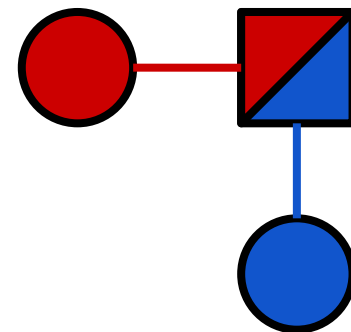
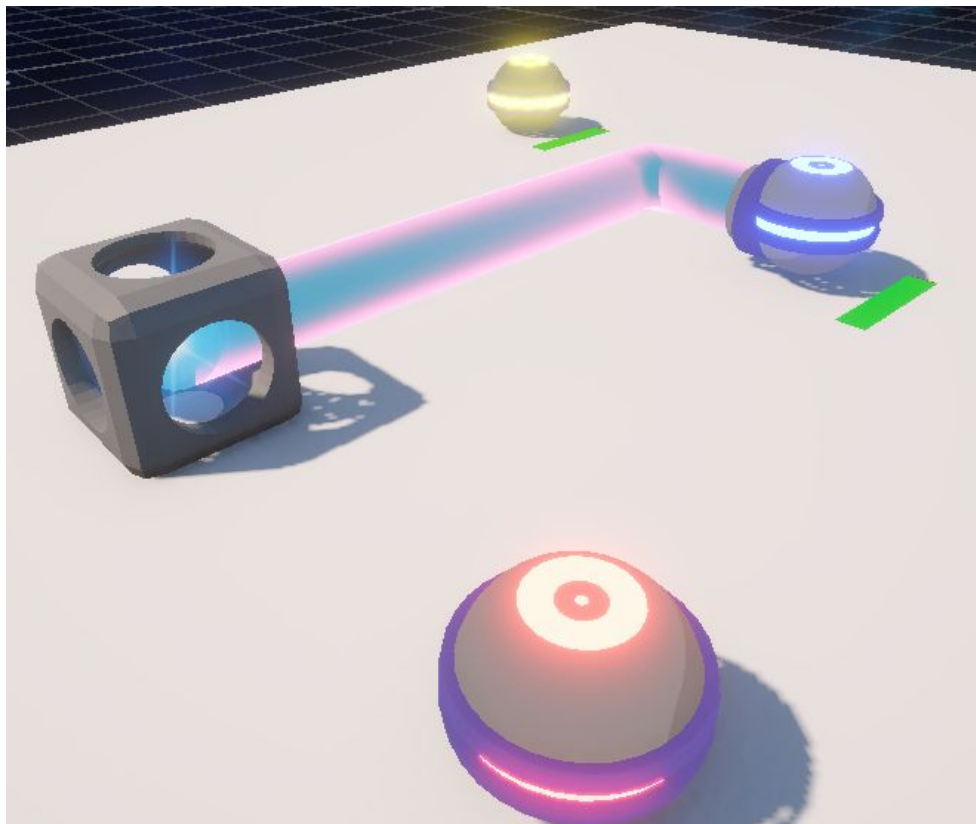

# Multilayer Gameplay

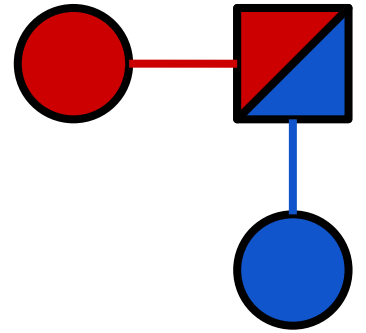

# Player Inventory

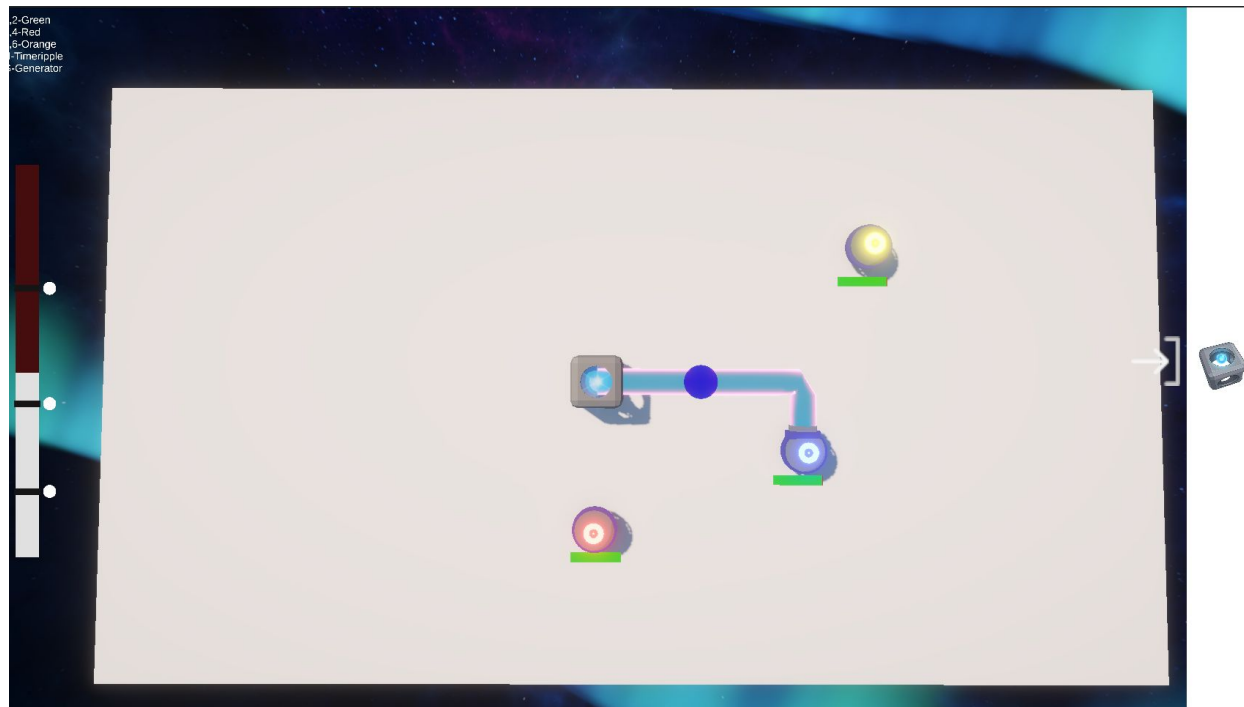
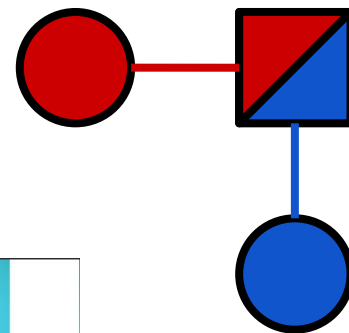

# Implementation

- One simulation: Simulation logic works across layers
- Ripple Spawning: Randomized seed based instantiation

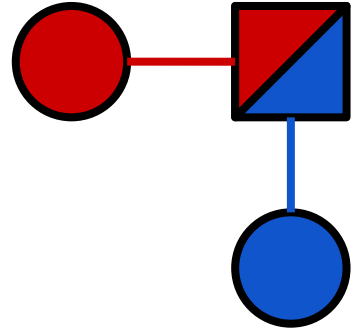

## Next Steps

- Experiment with simulation params

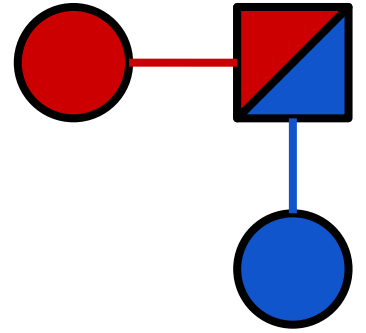

# The Time-Space fabric collapses!

